



USER'S MANUAL



POWER MAGIC

125kW 400Vac



ZUCCHETTI
Centro Sistemi





Power Magic

400V C&I

User Manual



Table of Contents

1.	Preliminary safety instructions	7
1.1.	Safety instructions	7
1.1.1	Personal safety.....	8
1.1.2	Equipment Safety.....	10
1.1.3	Environmental requirements	12
2.	Product Introduction	14
2.1	Product Description.....	14
2.2	Function and Features	14
2.3	Models description.....	16
2.4	System architecture description	16
2.5	Overall dimensions	18
2.6	Components introduction	21
3.	Transport and Storage.....	27
3.1	Transport considerations.....	27
3.2	Storage requirements	29
4.	Installation	31
4.1	Installation requirements	31
4.1.1	Installation environment requirements.....	31
4.1.2	Installation operation requirements	31
4.2	Foundation.....	32
4.2.1	Foundation construction requirements.....	32
4.2.2	Requirements for installation space.....	34
4.2.3	Recommended foundation drawings	37
4.2.4	Optional customized steel base	38
4.3	Hosting and fixing.....	39
4.3.1	Preparation tools	39
4.3.2	Check before installation.....	41
4.3.3	Installation and fixing work	42



- 4.3.4 Fixed operation of cabinets connection scheme 47
- 4.3.5 Customized steel base installation 49
- 5. Electrical connections 52
 - 5.1 Safety precautions 52
 - 5.1.1 Wiring requirements 52
 - 5.1.2 Short Circuit protections 53
 - 5.1.3 Grounding requirements 54
 - 5.1.4 Antistatic requirements 54
 - 5.2 Wiring preparation 55
 - 5.2.1 Preparation of installation tools 55
 - 5.2.2 Preparation of cables 56
 - 5.2.3 Cable compression and connection 58
 - 5.2.4 Open the cabinet doors and equipment compartment doors 59
 - 5.2.5 Cable entrance design 60
 - 5.3 Ground connection 61
 - 5.4 Cable wiring between cabinets 62
 - 5.5 PCS AC power cord connections 63
 - 5.6 Signal terminals wiring 65
 - 5.7 Communication cable connections 69
 - 5.8 Operations after cable wiring 71
- 6. Piping of additional storage cabinets 72
 - 6.1 Preparing tools for Liquid cooling system piping 72
 - 6.1.1 Sealing inspection of liquid cooling pipelines in cabinets 72
 - 6.1.2 Installation of liquid cooling pipelines in cabinets 76
 - 6.2 Installation of fire protection pipelines in parallel cabinets 79
- 7. Power up and shut down operations 81
 - 7.1 Indicator lights status description 81
 - 7.2 Power on operations 82
 - 7.2.1 Check before powering on 83
 - 7.2.2 Steps for powering on under normal conditions 83
 - 7.3 Shut down under normal conditions 86



7.4	Shut down under emergency conditions.....	88
8.	Maintenance and warranty	90

General instructions

This manual contains important safety instructions that must be followed during installation and maintenance of the equipment.

Please keep these instructions!

This manual must be considered an integral part of the equipment, and must be available at all times to everyone who interacts with the equipment. The manual must always accompany the equipment, even when it is transferred to another user or plant.

Copyright statement

Copyright of this manual belongs to Zucchetti Centro Sistemi S.p.A. No part of this manual (including the software, etc.) may be copied, reproduced or distributed in any form or by any means without the permission of Zucchetti Centro Sistemi S.p.A. All rights reserved. ZCS reserves the right to final interpretation. This manual is subject to change based on feedback from users, installers or customers. Please check our website at <http://www.zcsazzurro.com> for the latest version.

Technical support

ZCS offers a support and technical consultancy service accessible by sending a request directly from the website <https://www.zcsazzurro.com/it/support>.

The following toll-free number is available for the Italian territory: 800 72 74 64.



Preface

General information

Please read this manual carefully before installation, use or maintenance.

This manual contains important safety instructions that must be followed during installation and maintenance of the system.

Scope

This manual describes the assembly, installation, electrical connections, commissioning, maintenance and troubleshooting of the following inverters:

POWER MAGIC

Keep this manual so that it is accessible at all times.

Recipients

This manual is intended for qualified technical personnel (installers, technicians, electricians, technical support personnel or anyone who is qualified and certified to operate a storage system), who are responsible for installing and starting the inverter in the photovoltaic system and for operators of the photovoltaic system.

Symbols used

This manual provides information for safe operation and uses certain symbols to ensure the safety of personnel and materials, and for efficient use of the equipment during normal operation. It is important to understand this information to avoid accidents and damage to property. Please take note of the following symbols used in this manual.

	Danger: indicates a hazardous situation which, if not resolved or avoided, could result in serious personal injury or death.
Danger	
	Warning: indicates a hazardous situation which, if not resolved or avoided, could result in serious personal injury or death.
Warning	

	<p>Caution: indicates a hazardous situation which, if not resolved or avoided, could result in minor or moderate personal injury.</p>
<p>Caution</p>	
	<p>Attention: indicates a potentially hazardous situation which, if not resolved or avoided, could result in damage to the system or other property.</p>
<p>Attention</p>	
	<p>Note: provides important tips on the correct and optimal operation of the product.</p>
<p>Note</p>	

1. Preliminary safety instructions



Note

If you have problems or questions regarding the reading and understanding of the following information, please contact Zucchetti Centro Sistemi S.p.A. through the appropriate channels.

General information in this chapter

Safety instructions

It mainly highlights the safety instructions to be followed during installation and use of the equipment.

Symbols and icons

Introduces the main safety symbols on the inverter.

1.1. Safety instructions

Before installing and using the equipment, make sure you read and understand the instructions in this manual and familiarise yourself with the relative safety symbols shown in this chapter.

Depending on national and local requirements, permission must be obtained from your local provider before connecting to the electrical grid, making sure that the connections are carried out by a qualified electrician.

Contact the nearest authorised service centre for any repairs or maintenance. Contact your distributor for information on the nearest authorised service centre. **DO NOT** carry out repairs yourself, as this may result in injury or damage.

Qualified personnel

Ensure that the operator has the necessary skills and training to operate the equipment. Personnel responsible for use and maintenance of the equipment must be qualified and capable of performing the activities described, and must also have appropriate knowledge on how to correctly interpret the contents of this manual. For safety reasons, this inverter can only be installed by a qualified electrician with the necessary training and/or skills and knowledge. Zucchetti Centro Sistemi S.p.A. declines all responsibility for damage to property or personal injury caused by incorrect use of the device.

1.1.1 Personal safety

 <div style="background-color: red; color: white; padding: 5px; text-align: center; font-weight: bold;">Danger</div>	<p>Lethal high voltage is present inside the equipment!</p> <p>Observe and comply with the warning signs on the equipment.</p> <p>Observe the safety precautions listed in this manual and other relevant documents for this equipment.</p> <p>Observe the relevant protective requirements and precautions for batteries.</p> <p>There is a risk of electric shock from touching the power supply or the contacts, terminals, etc. connected to it inside the equipment!</p> <p>Special protective equipment must be used during operation, such as protective clothing, insulated shoes, goggles, safety helmets and insulated gloves.</p>
--	--

 <div style="background-color: orange; color: white; padding: 5px; text-align: center; font-weight: bold;">Warning</div>	<p>Always use the energy storage system in accordance with this manual.</p> <p>To prevent accidents, observe the following precautions:</p> <p style="padding-left: 40px;">In the vicinity of the energy storage system, place visible warning signs to prevent accidents caused by misclosing.</p> <p style="padding-left: 40px;">In the vicinity of the equipment, erect warning signage or set up safety caution tape.</p>
--	---

 <div style="background-color: blue; color: white; padding: 5px; text-align: center; font-weight: bold;">Attention</div>	<p>The indicator light of the equipment should be evacuated from the scene when the red light is flashing.</p>
--	---

The lifting and transportation, installation and wiring, operation and maintenance of energy storage system must be carried out by professional and technical personnel in accordance with local norms. Operators responsible for the installation and maintenance of equipment need to meet the following requirements:

- You must first undergo rigorous training, master the correct operation method, be familiar with the composition and working principle of the energy storage system and its front and rear equipment, and understand the various safety precautions and the relevant standards of your country/region.
- A person who has received professional training related to the installation and commissioning of electrical equipment and who is able to be aware of the various potential sources of hazards and the magnitude of the hazards during the installation, operation, and maintenance of the equipment.

- Should have some electronic, electrical wiring and mechanical expertise and be familiar with electrical and mechanical schematics.
- Emergency response capability should be available in the event of a hazardous or unexpected situation during installation or commissioning.
- Personnel in special scenarios such as electrical operations, work at heights, and operation of special equipment must have special operating qualifications required by the local country/region.
- Operators of medium voltage equipment must hold a high voltage electrician's licence.
- Keep persons other than those operating the equipment away from the equipment.
- The installation process is strictly prohibited to operate with electricity. It is prohibited to install or remove cables with electricity. The wire and cable cores will generate electric arc, electric spark or fire and explosion at the moment of contacting the conductor, which can lead to fire or personal injury.
- When equipment is energized, unregulated and incorrect operation may produce a fire, electric shock or explosion, resulting in injury, death or property damage.
- It is strictly prohibited to wear watches, bracelets, bangles, rings, necklaces and other easily conductive objects during operation to avoid electric shock burns.
- Special insulated tools must be used during operation to avoid electric shock or short-circuit faults, and the insulation voltage withstand level must meet the requirements of local laws and regulations, standards and codes.
- Do not deactivate equipment protection devices and ignore warnings, cautions and precautions in manuals and on equipment.
- During the operation of the equipment, if a fault is detected that may lead to personal injury or equipment damage, the operation should be terminated immediately, reported to the person in charge, and effective protective measures should be taken.
- Do not power up the unit without completing the installation or without professional confirmation.
- It is prohibited to contact the power supply equipment directly, with other conductors or indirectly through wet objects, and the voltage at the point of contact should be measured before contacting any conductor surface or terminal to confirm that there is no danger of electric shock.
- When the unit is in operation, the housing is hot and there is a risk of burns, so do not touch it.
- Do not allow fingers, parts, screws, tools or veneers to touch the running fan to avoid injury to hands or damage to the unit.
- In the event of a fire, evacuate the building or equipment area and ring the fire alarm or call the fire alarm. Under no circumstances should you re-enter a burning building or equipment area.

1.1.2 Equipment Safety

1.1.2.1 Energy Storage system safety

	<p>Avoid standing at the cabinet door (including within the opening range of the door) when the energy storage system is malfunctioning.</p> <p>It is forbidden to open the cabinet door when the system is running.</p>
Danger	

- The layout of the energy storage system installation must meet fire distance or fire wall requirements as specified by local standards, including but not limited to 《GB 51048-2014 Design Code for Electrochemical Energy Storage Station》、《NFPA 855 Standard for the Installation of Stationary Energy Storage Systems》 specification requirements.

- When inspecting the system with electricity, pay attention to the hazard warning signs on the equipment and avoid standing at the cabinet door.

- After the power components of the energy storage system are replaced or the wiring is changed, it is necessary to manually start the wiring detection to avoid abnormal system operation.

- It is recommended that users provide their own camera devices to record the detailed process of installation, operation and maintenance of the equipment.

- The energy storage system must be equipped with protective measures such as fences and walls, and safety warning signs must be erected for isolation, so as to avoid the entry of unauthorized personnel during the operation of the equipment, which may lead to personal injury or property damage.

1.1.2.2 Battery safety

	<p>Do not expose the battery to high temperature environments or around heat-generating equipment, such as high temperature sunlight, sources of ignition, transformers, heaters, etc. Overheating of the battery may cause leakage, smoke, release of flammable gases, thermal runaway, fire or explosion.</p> <p>It is strictly prohibited to disassemble, modify or damage the battery (e.g. inserting foreign objects, extruding with external force, immersing in water or other liquids), which may cause battery leakage, smoke, release of flammable gases, thermal runaway,</p>
Danger	

fire or explosion.

It is strictly prohibited to subject the battery to mechanical vibration, dropping, collision, piercing by hard objects and pressure shock, or it may lead to battery damage or fire.

It is strictly prohibited for the battery terminals to come into contact with other metal objects, which may cause heat generation or electrolyte leakage.

● For safe use of the product, the technician should carefully read and strictly observe the safety requirements. The Company shall not be liable for product functional abnormality, component damage, personal safety accident, property loss, or other damage caused by the following reasons:

● The batteries are not charged as required, resulting in capacity loss or irreversible damage to the batteries.

● A battery is damaged, falls, or leaks due to improper operations or failure to operate the battery as required.

● The batteries are not powered on in time, which causes damage to the batteries due to over discharge.

● The damage is caused to batteries due to the use of improper equipment for charging and discharging.

● Batteries are frequently over discharged due to improper maintenance, capacity is incorrectly expanded, or the batteries have not been fully charged for a long time.

● Battery operation parameters are incorrectly set.

● Damage is caused to batteries because the battery operating environment does not meet the requirements.

● The customer uses the batteries beyond the scenarios specified in this manual, including but not limited to connect extra loads.

● Batteries are not maintained based on the system manual.

● The product is damaged due to the customer's continued use of batteries beyond the warranty period.

● The product is damaged due to the use of defective or deformed batteries.

● Use batteries provided by the Company with other batteries, including but not limited to batteries of other brands or batteries of different rated capacities.

● Product damage or property loss are caused due to storing or installing batteries with flammable/explosive materials.

- Personal safety accidents and property loss are caused by battery-related operations performed by non-professional personnel, or by not wearing qualified protective equipment during operations.
- The battery is damaged due to eating, drinking, smoking and other behaviours near the battery.
- Batteries are stolen.

1.1.3 Environmental requirements

	<p>It is strictly prohibited to store flammable or explosive substances in the equipment area.</p>
<p>Danger</p>	<p>It is strictly prohibited to place the equipment in an environment of flammable or explosive gases or fumes, and it is prohibited to carry out any operation in such an environment.</p> <p>It is strictly prohibited to place the equipment close to sources of heat or fire, such as pyrotechnics, candles, heaters or other heat-generating devices; heat applied to the equipment may cause damage to the equipment or lead to fire.</p>

- Equipment should be stored in a suitable temperature and humidity environment, in a clean, dry, well-ventilated area, and protected from dust and condensation.
- It is strictly prohibited to install and operate the equipment beyond the range specified in the technical specifications, otherwise the performance and safety of the equipment will be affected.
- It is strictly prohibited to install, use and operate outdoor equipment and cables (including, but not limited to, handling equipment, operating equipment and cables, plugging and unplugging signal interfaces connected to the outdoor area, working at height, outdoor installation, opening doors, etc.) under severe weather conditions such as thunder, lightning, rain, snow, and gusts of wind of more than six degrees.
- It is strictly prohibited to install the equipment in an environment with dust, fumes, volatile gases, corrosive gases, infrared and other radioactive radiation, organic solvents or excessive salt content.
- It is strictly prohibited to install the equipment in an environment with metallic conductive dust, conductive magnetic dust.
- Installation environment ground is solid, no rubber soil, weak soil or easy to sink and other adverse geological, strictly prohibit the selection of low-lying areas or areas prone to water logging, site level should be higher than the highest historical water level in the region.
- If the equipment is installed in a site with heavy vegetation, in addition to routine weeding, the ground underneath the equipment needs to be hardened, e.g., by laying cement, gravel, etc.

- When installing, operating, or maintaining the unit, clean the top of the unit of any standing water, ice, snow, or other debris before opening the door to prevent debris from falling into the interior of the unit.
- When mounting the equipment, make sure that the mounting surface is sturdy and meets the equipment's load-bearing requirements.
- The line holes need to be sealed. The line holes that have been lined are sealed with sealing mud, and the line holes that have not been lined are sealed with the cover of the equipment.
- After installing the equipment, empty packing materials such as cardboard boxes, foam, plastic, cable ties, etc. should be removed from the equipment area.



2. Product Introduction

2.1 Product Description

PowerMagic C&I battery energy storage systems is mainly used in energy storage project, photovoltaic + energy storage system, integrated PV-storage-charging station, micro-grid and other scenarios, which mainly save the electricity cost for enterprises through the peak and valley electricity price difference, demand response and ancillary service and so on.

Typical applications of the PowerMagic C&I energy storage system are illustrated below:



Figure 1 - Typical installation

2.2 Function and Features

Solutions

PowerMagic energy storage system includes: energy storage cabinet (with PCS and liquid cooling unit), battery cabinet, 400V Junction Cabinet, Backup cabinet, to provide a complete solution for customers.

Flexible capacity design

In terms of different capacity requirements, PowerMagic can flexibly realize the capacity expansion both in AC side and DC side. Up to 6 energy storage cabinets can work in parallel with one 400V junction cabinet. And each one energy storage cabinet can connect with maximum 3 battery cabinet, which makes the system duration hours from default 2 hours to 8 hours.

Liquid and electricity separation design

The DC cables of the system is designed on the top of the cabinets and the pipes for the liquid cooling system is at the bottom of the cabinets. Through this design scheme, the potential risks of electrical connection safety problems caused by the leakage of cooling liquid is eliminated, which can greatly improve the safety and reliability of the system.

3 + 2 Safety Design

'3' refers to the 3 levels of fire suppression in PowerMagic.

The first level is pack level perfluorohexanone gas fire fighting.

The second level refers to the cabinet level + auxiliary box level perfluorohexanone gas fire fighting.

The third level refers to water fire fighting.

'2' refers to the explosion vent design and combustible gas emissions design.

Liquid cooling + Anti-condensation system

The liquid cooling system of PowerMagic can effectively solve the problems of temperature unbalance, short life and low efficiency among the batteries. By adding the anti-condensation device, the dew point temperature can be effectively reduced to lower the condensation possibility..

Auto grid on/off

PowerMagic energy storage system can meet the fast on-grid and off-grid auto-switching requirements.

Local EMS Features:

- System against backflow;

Parallel charging and discharging power equalisation; (allocation of charging and discharging power to each storage cabinet according to the state of each battery stack)

- System WEB monitoring interface;
- Demand-side response;

No real-time dispatch, prior declaration, communication with grid or third-party media for reporting

- Peak shaving/capacity to demand;

Input of local peak and valley tariff information, smoothing of load profiles and ensuring that peak power is within limits)

- Supports remote and local control and upgrade

Install and start the inverter according to the following instructions. Place the inverter on suitable load-bearing supports with sufficient load capacity (such as walls or photovoltaic racks) and make sure that the inverter is positioned vertically. Choose a suitable location for the installation of the electrical equipment.

Make sure there is sufficient space for heat dispersion and to accommodate future maintenance. Maintain adequate ventilation and ensure that there is enough air circulation for cooling.

2.3 Models description

2.4 System architecture description

- Single Energy Storage Cabinet scenario (2h/4h/6h/8h): Back up Cabinet (Optional) + 1 Energy Storage cabinet + 1 - 4 Battery Cabinets;

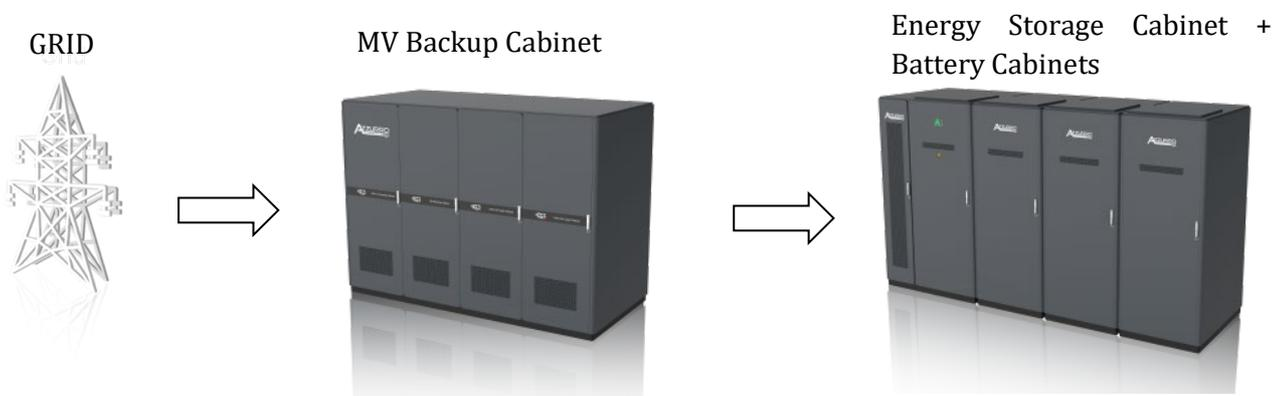

- Multi Energy Storage Cabinet scenario (2h/4h/6h/8h): Back up Cabinet (Optional) + 400V Junction Cabinet + 1-6 Energy Storage Cabinet + 2 – 24 Battery Cabinets (ALTERNATIVE 1)

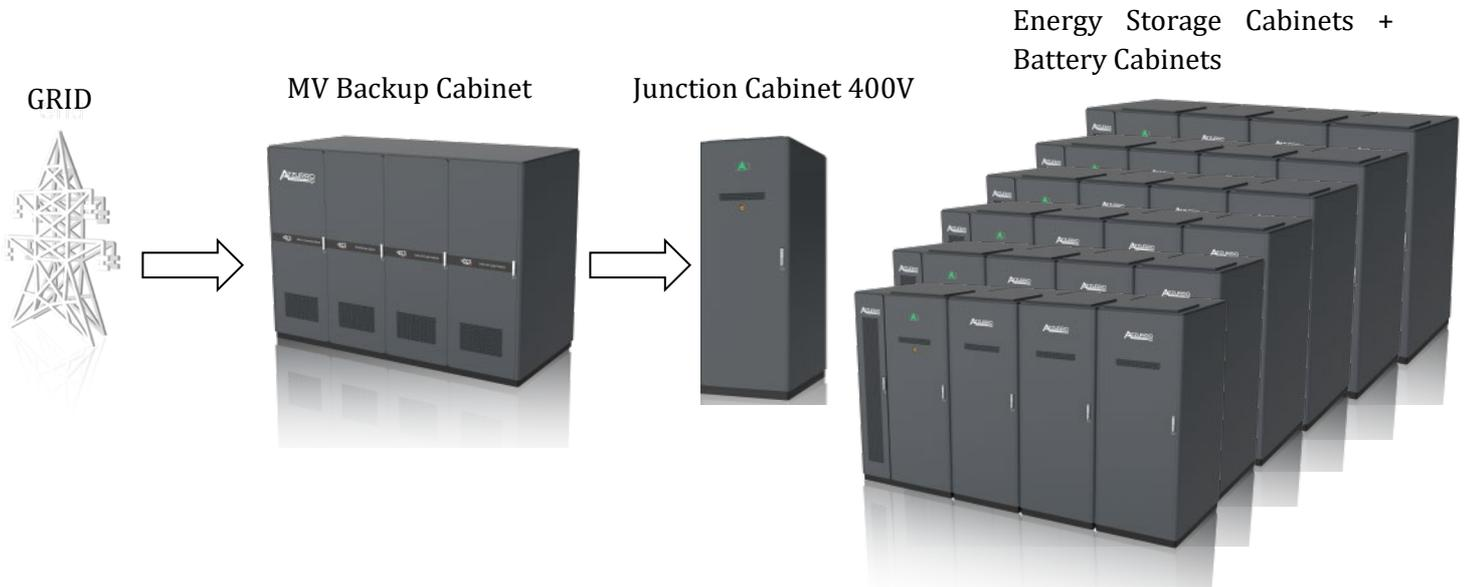

- Multi Energy Storage Cabinet scenario (2h/4h/6h/8h): Back up Cabinet (Optional) + 400V Junction Cabinet + 1-6 Energy Storage Cabinet + 2 – 24 Battery Cabinets (ALTERNATIVE 2)

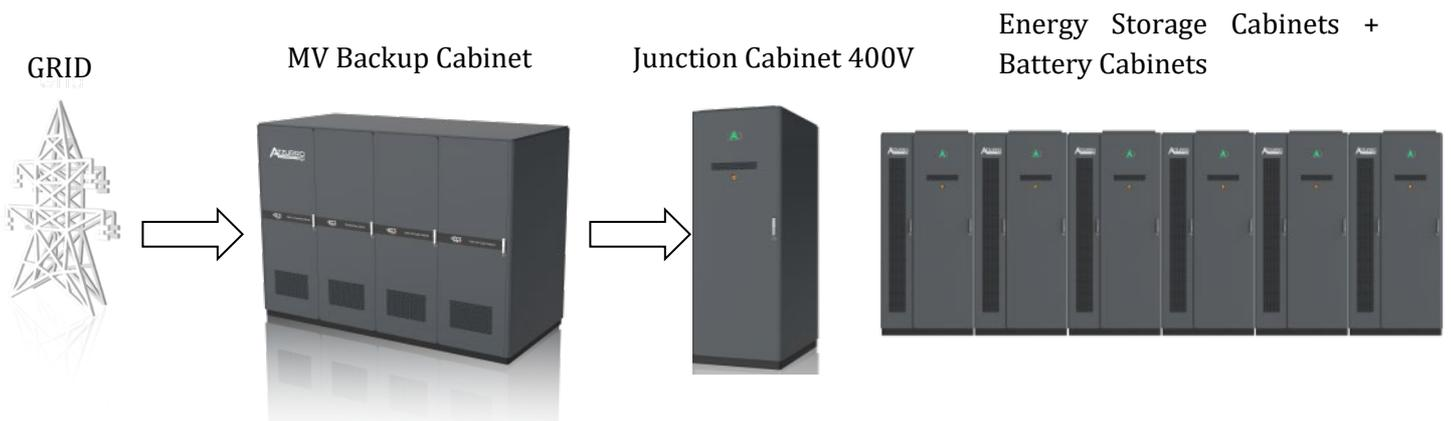

2.5 Overall dimensions

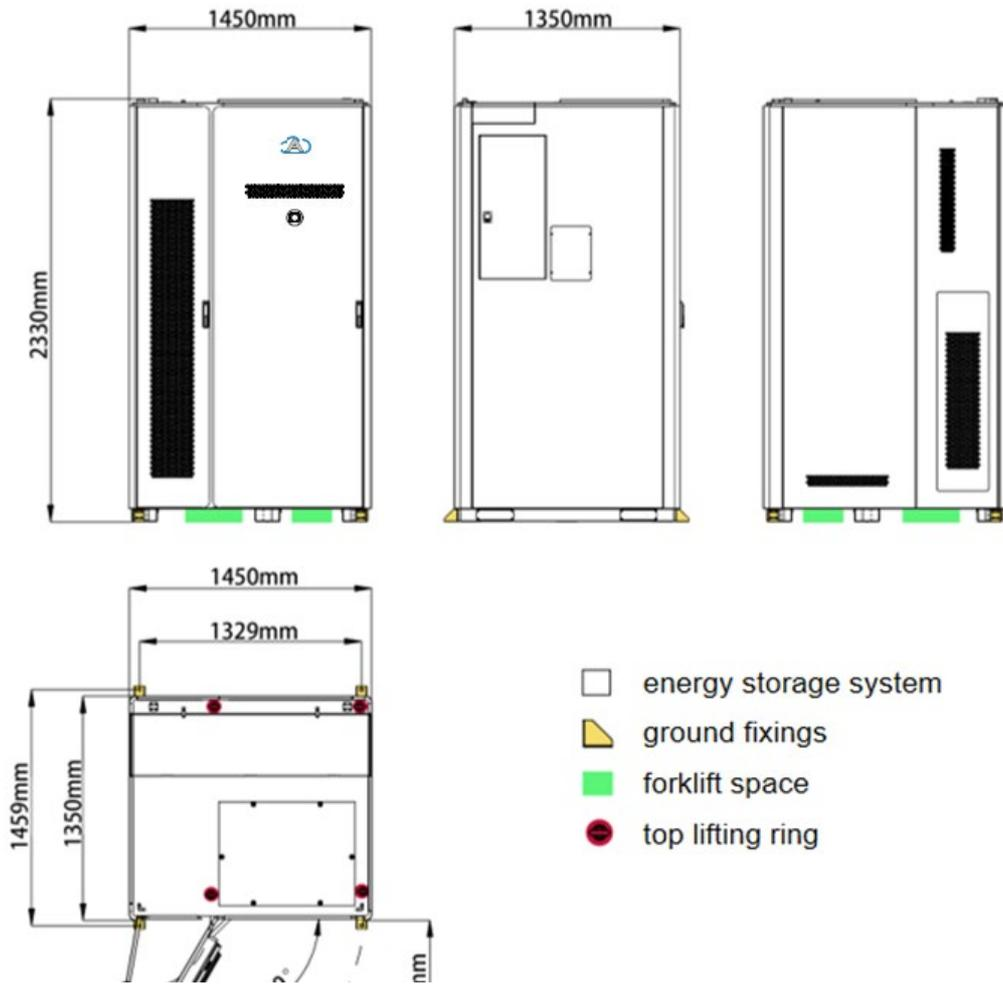

Figure 2 - Dimensions and maximum door opening size for 400V Energy Storage Cabinet

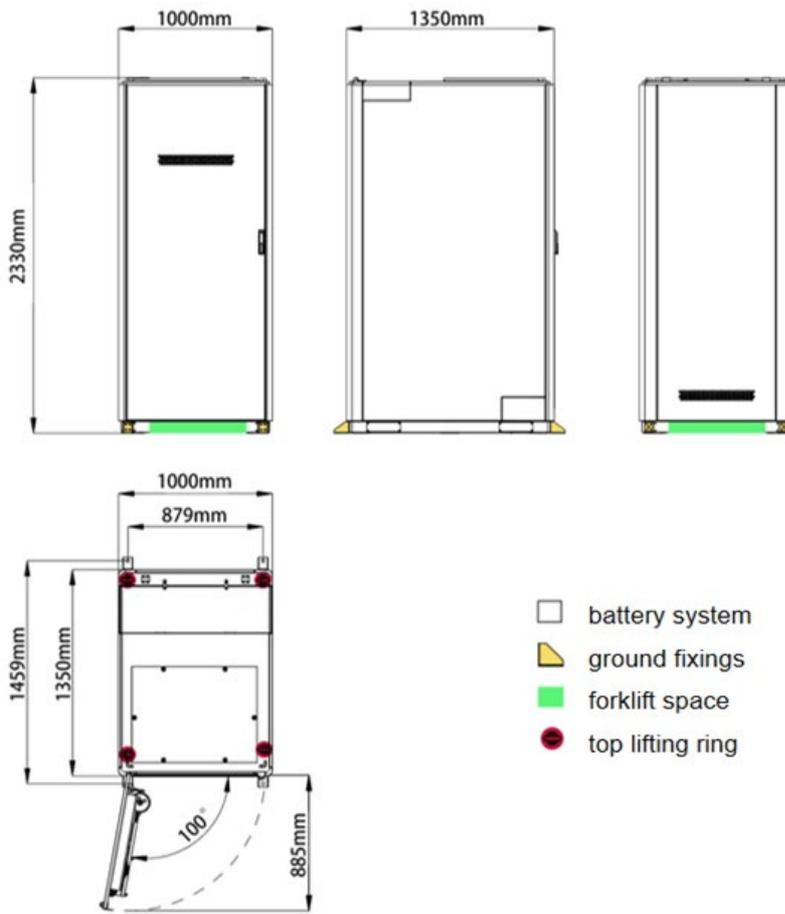

Figure 3 - Dimensions and maximum door opening size for 400V Battery Cabinet



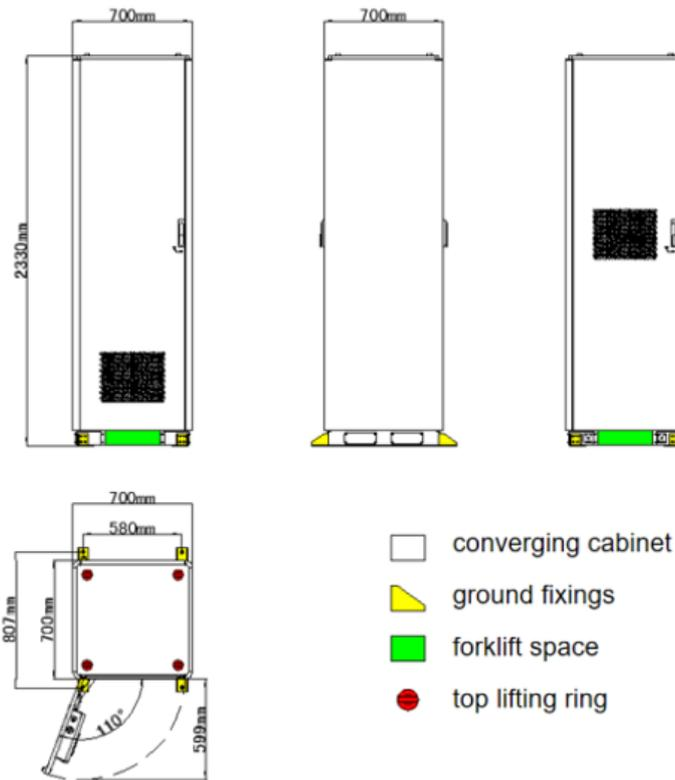

Figure 4 - Dimensions and maximum door opening size for 400V Junction Cabinet

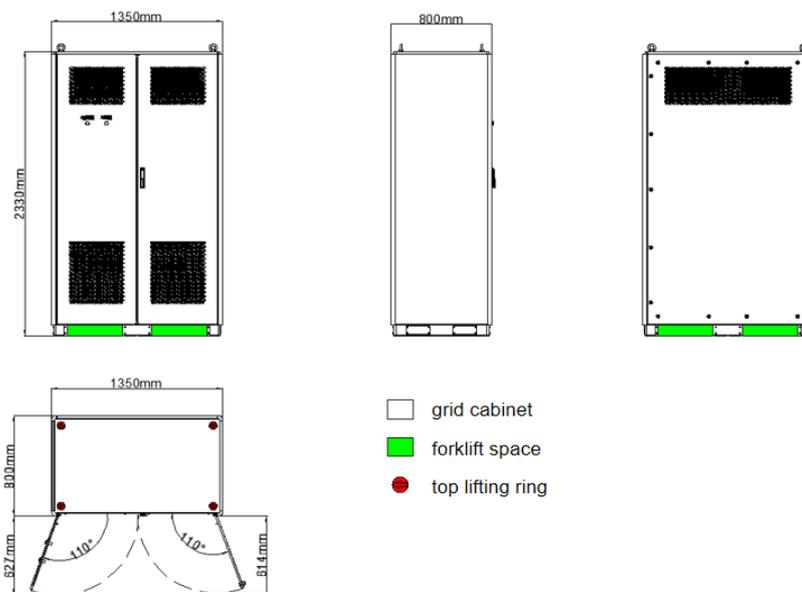

Figure 5 - Dimensions and maximum door opening size for 400V Backup Cabinet



2.6 Components introduction

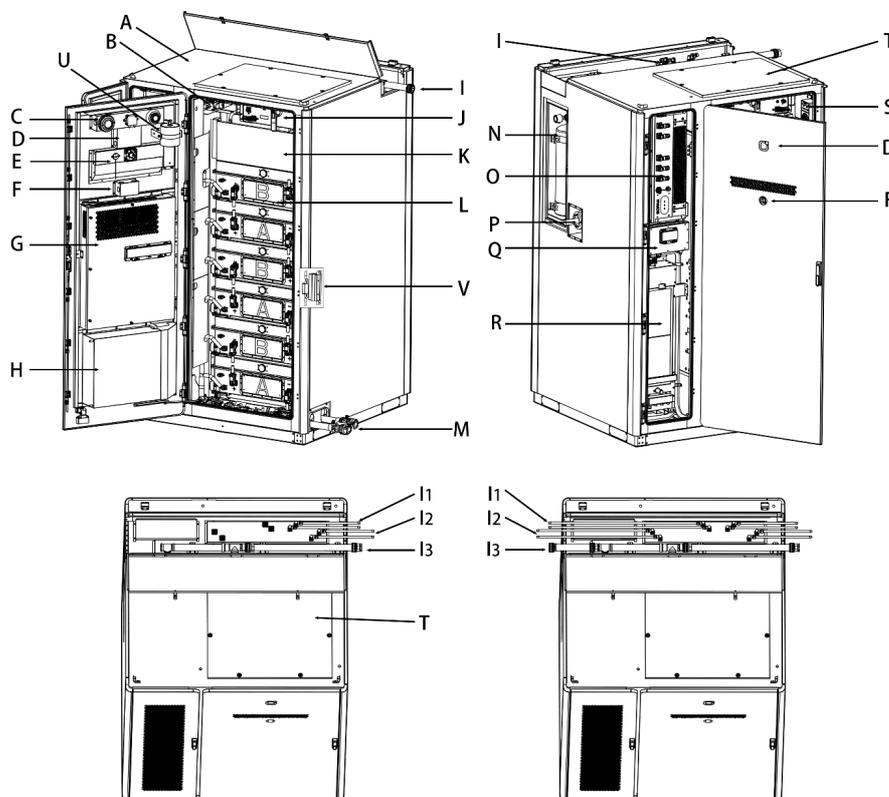

Figure 6 – Components for Energy Storage Cabinet

NO.	Name	Qty	Statement
A	Cabinet enclosure	1	
B	Fuse	2	
C	Temperature/smoke/combined detectors	1	
D	Logo indicator	1	For displaying the operating status of the device
E	Buzzer/fan	1	Fire alarm/Gas emission
F	Emergency stop button	1	Emergency start, stop

G	Auxiliary power modules	1	
H	CSU	1	optional
I	Terminals/fire fighting pipe	1	See I1~I3 for details
J	High voltage box	1	Switch
K	Sealing board	1	
L	PACK	5 or 6	5 packs in 215kWh cabinet 6 packs in 258kWh cabinet
M	Liquid Cooling pipes	2	
N	Fire suppression bottle assembly	1	
O	PCS	1	125kW PCS
P	Water hydrant connection	1	
Q	Junction box	1	
R	Liquid cooling machine	1	
S	Dehumidification module	1	
T	Explosion vent	1	
U	Aerosol	1	
V	Fuses inside cluster	1	
I1	Power terminals	2	
I2	Signal terminals	2	
I3	Fire fighting pipe	1	



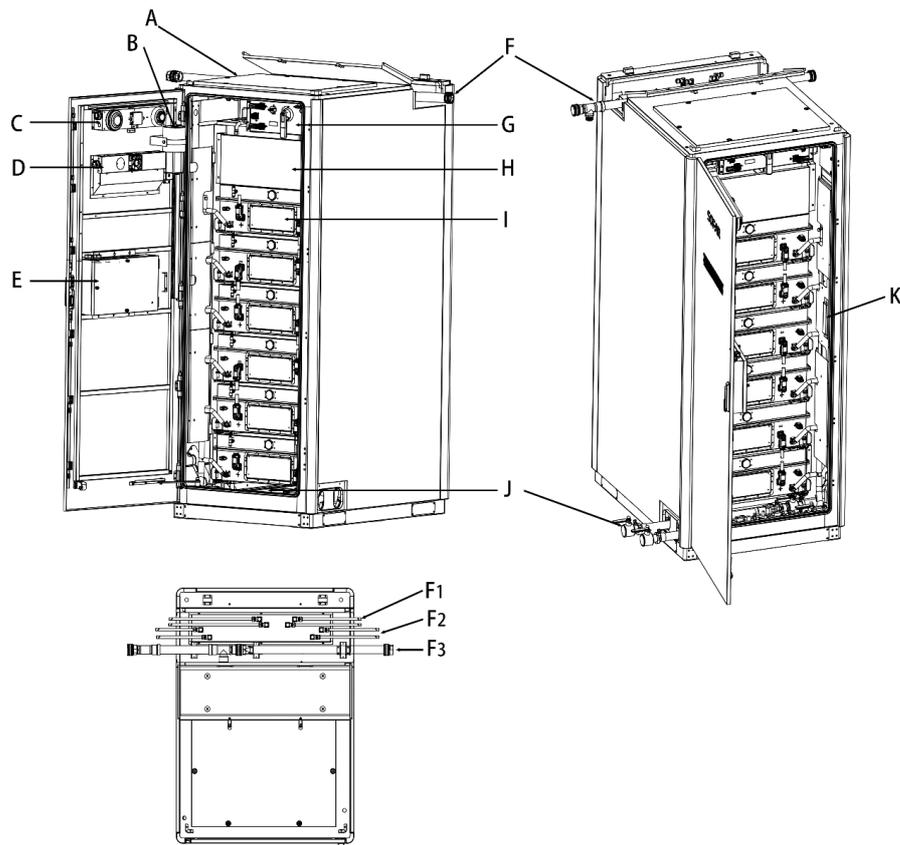

Figure 7 - Components for Battery Cabinet

NO.	Name	Qty	Statement
A	Cabinet	1	
B	Aerosol	1	
C	Temperature/smoke/combined detectors	1	
D	Buzzer/fan	1	Fire alarm/Gas emission
E	Auxiliary power module	1	
F	Terminals/firefighting pipe	1	See F1~F3 for details
G	High voltage box	1	

H	Sealing board	1	
I	PACK	5 or 6	5 packs in 215kWh cabinet 6 packs in 258kWh cabinet
J	Liquid cooling pipes	2	
K	Cluster fuses	1	
F1	Power terminals	2	
F2	Signal terminals	2	
F3	Firefighting pipe	1	

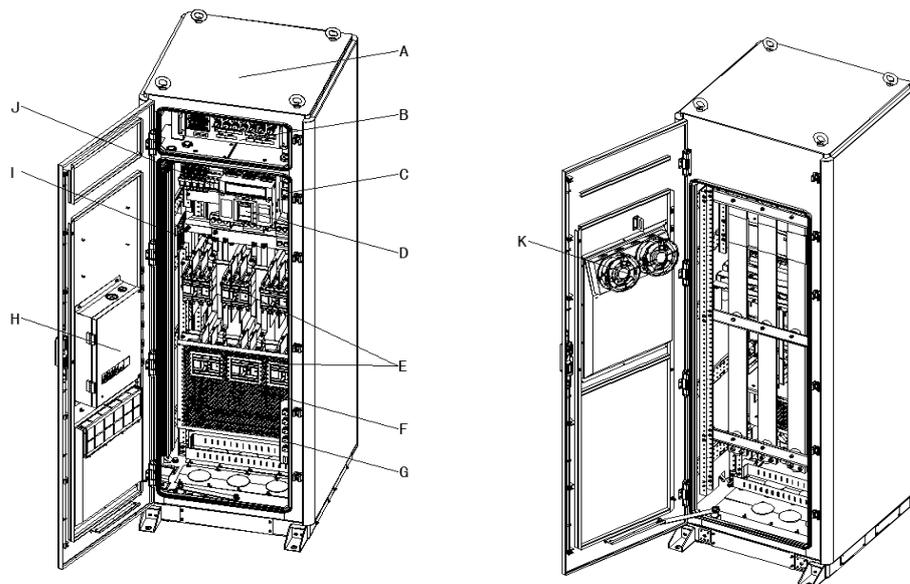

Figure 8 – Components for Junction Cabinet

NO.	Name	Qty	Statement
A	Cabinet	1	
B	CSU box	1	
C	Meter	1	
D	Circuit breaker	1	
E	Branch circuit breaker	2~6	Max 6pcs
F	Protection plate	2	
G	Communication interface	1	
H	Junction box	1	
I	Dehumidifier	1	

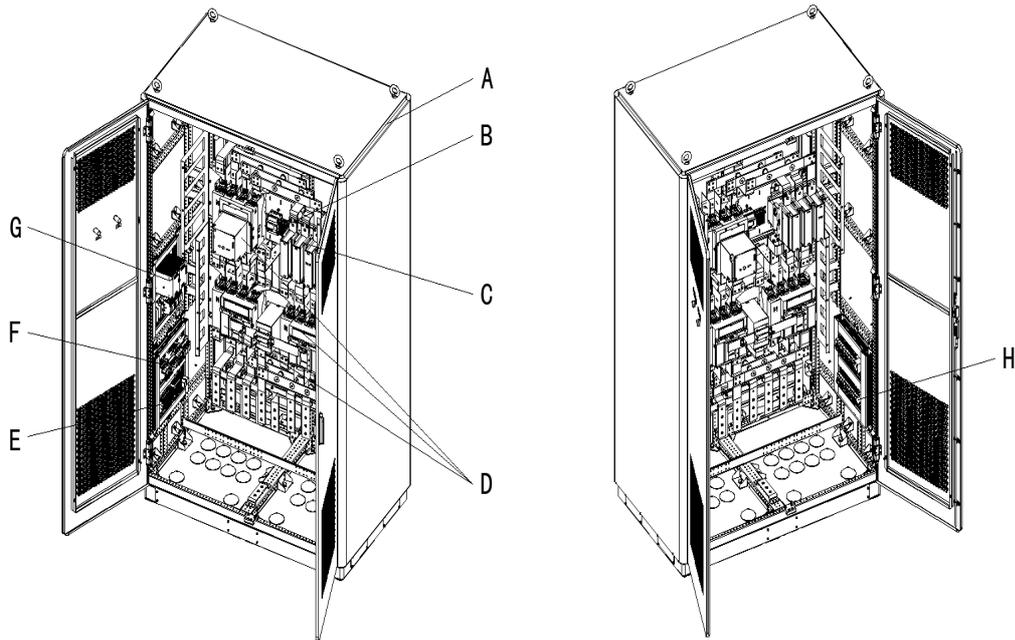

Figure 9 - Components for Backup Cabinet

NO.	Name	Qty	Statement
A	Cabinet	1	
B	Meter	1	
C	ACt contactors	4	
D	MCCB (or STS)	1	
E	Wiring terminal	1	
F	Lightning protector	1	
G	Power supply	1	
H	Miniature Circuit Breaker	1	

3. Transport and Storage

3.1 Transport considerations

 <div style="background-color: orange; color: white; padding: 5px; text-align: center; font-weight: bold;">Warning</div>	<p>In the whole process of loading, unloading, transport, must comply with the project in the country/region of the container operation safety regulations!</p> <p>In the whole process of loading, unloading and transport, must meet the transport origin country, route country, destination country transport container operation specification and regulatory requirements!</p> <p>The energy storage system mechanical parameters (dimensions and weights) should be kept in mind during the operation.</p> <p>All personnel involved in loading, unloading and bolting should receive appropriate training, especially in safety.</p>
--	--

 <div style="background-color: yellow; color: black; padding: 5px; text-align: center; font-weight: bold;">Caution</div>	<p>Failure to transport and store in accordance with the requirements of this manual may void the warranty.</p>
---	--

- The energy storage system can be delivered directly to the site to meet the requirements for transport by vehicle or ship; it complies with the IMDG CODE and the International Maritime Dangerous Goods Code (IMDG CODE) transport requirements for sea transport, and with ADR or JT T617 transport requirements for land transport.

- The Energy Storage System is not currently permitted for air transport and does not support rail transport.

- With the integrated design of the energy storage system, handling only requires the use of a forklift to lift and transport the entire chassis.

Transportation and mobile energy storage systems should meet the following conditions:

- The doors of each cabinet of the energy storage system are locked tightly, and there are no foreign objects sticking out of the box.

- According to the site conditions, choose the appropriate forklift, tools, the tools used must meet the energy storage system handling requirements.

- Be sure to set up warning signs or warning belts when handling to avoid non-staff entering the operation and transport area to avoid accidents.
- In case of bad weather conditions, such as heavy rain, fog, strong wind, etc., the operation should be stopped.
- Before using the forklift, you should make sure that the forklift meets the load-bearing requirements: the load-bearing capacity needs to be $\geq 4t$.
- Recommended fork blade length $\geq 1.4m$, width 80cm~160cm, thickness 25cm~70cm.
- Forklift lifting height requirements: when the height of the foundation is $\leq 0.3m$, the lifting height is $\geq 2m$; when the height of the foundation is $>0.3m$, the lifting height is increased accordingly.

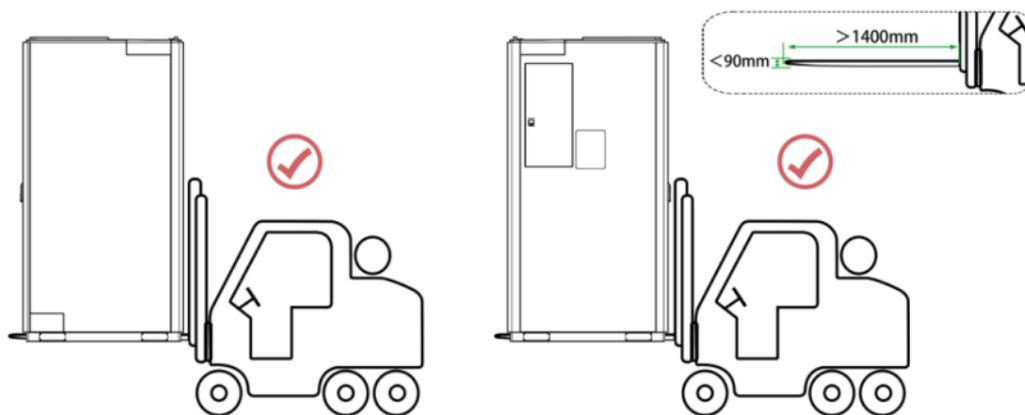

Figure 10 - Forklift transport front side

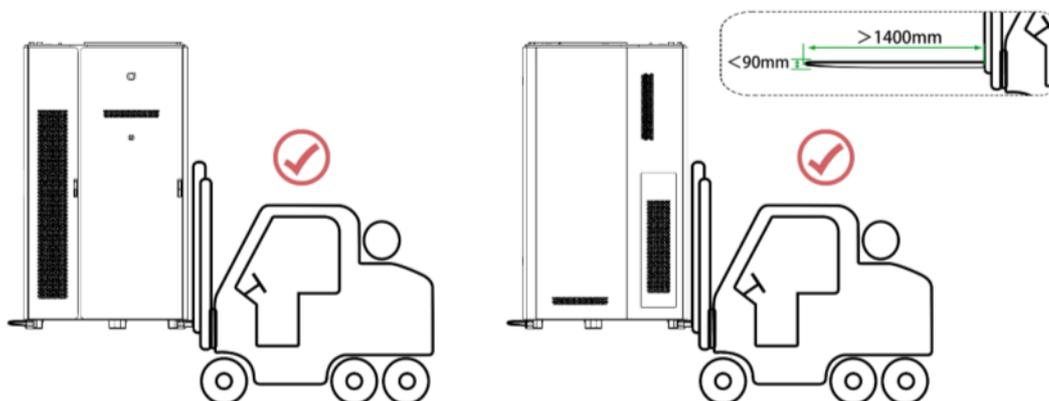

Figure 11 - Forklift side transport

3.2 Storage requirements

	<p>Before storage, the energy storage system systems should be checked and data recorded. Ensure that the cabinet door and the cabinet door of each device inside are locked and the power switch is in a safe state.</p>
<p>Note</p>	<p>During storage, it is necessary to provide relevant proof of compliance with product storage requirements, such as temperature and humidity log data, storage environment photos and inspection reports.</p> <p>The energy storage system and transport time is not more than 6 months in total (counting time from the start of shipment), should be used in a timely manner, lithium long-term storage will exist capacity loss.</p>

Storage environment requirements:

- Recommended storage temperature: 20°C~30°C;
- Relative humidity: 5%RH~80%RH;
- Dry, ventilated and clean;
- Avoid contact with corrosive organic solvents, gases and other substances;
- The distance from the heat source should not be less than two meters;

Storage location requirements:

- The storage location of the energy storage system should have sufficient bearing capacity (single cabinet $\geq 4t$), the ground needs to be level, the flatness should be $\leq 3mm$, no slope, and there is no accumulation of materials around.
- Before storage, the energy storage system should be reasonably padded according to the local meteorological conditions, to avoid rain or ground water erosion;
- The storage location should avoid mechanical impact, heavy pressure and strong magnetic field action.

Regular inspection:

- Inspect at least once every half a month to check whether the packaging is intact and undamaged to avoid insects and rodents, and replace it immediately if it is found to be damaged. Before installing the

energy storage system for long term storage (more than 6 months), it should be inspected and tested by professional personnel before it is put into use.

- Long-term storage of batteries is not recommended due to the capacity degradation that occurs when batteries are stored for long periods of time. In addition to this, even if the battery is stored at the recommended optimal storage temperature, there will be irreversible capacity degradation due to calendar effects, the longer the storage time, the greater the irreversible degradation, please refer to the technical agreement for specific degradation values. Stock batteries are shipped on a first-in-first-out basis.

- Calculated from the date of shipment, energy storage systems with a storage period of more than 6 months under the above conditions should be charged and discharged once to bring the system SOC up to 30%~40%, and the SOC needs to be consistent after replenishment.

- The air inlet and outlet of the energy storage system should be protected, and effective measures should be taken to prevent the intrusion of rainwater, sand and dust into the interior of the energy storage system.

4. Installation

4.1 Installation requirements

4.1.1 Installation environment requirements

- The external environment meets the requirements of 'GB 51048-2014 Design code for electrochemical energy storage station in China. Overseas project comply with NFPA 855 Standard for the Installation of Stationary Energy Storage Systems or IEC 62933-5-2 Safety Requirements For Grid-Integrated BESS.

- The equipment should be installed in an area away from liquids, and should not be installed under water pipes, air outlets and other locations that are prone to condensation; it should not be installed under air conditioning outlets, vents, server room outlet windows and other locations that are prone to water leakage to prevent liquids from entering the interior of the equipment and causing equipment malfunctions or short circuits.

- It is prohibited to place the equipment in an environment with flammable or explosive gases or fumes, and to perform any operation in such an environment.

- Installation of an energy storage system in a salt-affected area will cause corrosion and may result in a fire, so do not install an energy storage system outdoors in a salt-affected area. The area affected by sea breeze varies depending on meteorological conditions (e.g. typhoons, seasonal winds) or topography (presence of dykes, hills).

4.1.2 Installation operation requirements

- The operation area should be well marked with warning signs, and there should be at least one qualified supervisor responsible for industrial safety on site.
- Operators must undergo relevant training and obtain relevant certificates of competency before taking up their duties.
- Operators should do a good job of personal protection, wear helmets and safety belts; use all kinds of tools in a reasonable and compliant manner; any tools used in the operation should undergo maintenance and quality inspection.
- If special operations or work at height are required, they should report to the safety personnel if any in advance and take precautionary measures.
- In case of bad weather or unexpected situation, the work should be stopped immediately.

4.2 Foundation

4.2.1 Foundation construction requirements

Unreasonable foundation construction plan will bring more difficulties or troubles to the placement, opening and closing of the door and later operation of the BESS. Therefore, the foundation of the energy storage system must be designed and constructed in accordance with certain standards beforehand, so as to meet the requirements of mechanical support, cable routing, and later maintenance and overhaul.

	<p>As the energy storage system is heavy, the conditions of the installation site (mainly geological and climatic conditions) should be examined in detail before the foundation is constructed. Only on this basis can the design and construction of the foundation begin.</p> <p>Integrated foundations must be used.</p>
Warning	

Site selection requirements:

- The installation location should not be in a low-lying area and the installation level should be at least 300mm above the highest historical water level in the area.
 - Distance from airports, buried waste disposal sites, river banks or dams should be ≥ 2 km.
 - Choose an open location and ensure that there are no obstacles within 10m of the site.
 - Considering safety, the distance between the energy storage system and residential buildings is ≥ 12 m, and the distance from schools, hospitals and other densely populated buildings is > 30.5 m, or the distance should follow the local distance or regulation. If this safety distance is not met, the firewall between the energy storage system and the building should be built, convenient transport conditions and reliable fire suppression system should also be provided.
 - Meet the necessary installation site area and should leave enough room for capacity expansion according to the needs of the whole life.
 - Choose a well-ventilated site.
- Site locations should avoid scenarios that are not recommended by industry standards and regulations, including but not limited to the following lots, areas, and places:
- Strong vibrations, strong noise sources and strong electromagnetic field interference areas.
 - Places that generate or have dust, fumes, noxious gases, corrosive gases, etc.
 - Places where corrosive, flammable and explosive substances are produced or stored.

- Sites with existing underground facilities.
- Undesirable geological conditions such as rubbery soils, weak soils, ground prone to water-logging and subsidence.
 - Earthquake faults and seismic zones with a defence intensity higher than nine degrees.
 - Sections with direct hazards such as mudslides, landslides, quicksand, and caves.
 - Within the boundaries of the mining trap (stagger) area.
 - Within blasting hazard.
 - Areas that could be inundated if a dam or dike breaks.
 - Important sanitary protection areas for water supply sources.
 - Historic Monuments and Sites Conservation Area.
 - Intensively populated places, high-rise buildings, underground buildings.

Foundations shall be constructed to meet, as a minimum, the following requirements :

- The energy storage system must be mounted on concrete or other non-combustible surfaces, and the mounting plane must be level, firm, and flat, with sufficient bearing capacity to prohibit depressions or tilting.
- The equipment foundation is configured according to the total weight of the equipment $n*4t$ (n value 1~6, " n " indicates the number of energy storage cabinets) + $m*3t$ (m value 0~3, " m " indicates the number of battery cabinets), and when the load-bearing capacity of the foundation is not satisfied, it needs to be reviewed.
 - The bottom of the pit for the equipment foundation must be compacted and filled.
 - Equipment foundation excavation is strictly prohibited after soaking water disturbance, if soaking water disturbance should continue to excavate and refill.
 - Equipment foundation and cabinet contact surface level error $\leq 3\text{mm}$.
 - Foundations must be above the local historic high water level and at least 300mm above grade.
 - Construct drainage facilities in conjunction with local geological and municipal drainage requirements to ensure that water does not accumulate at the equipment foundations. The foundations should be constructed to meet the local historical maximum rainfall drainage requirements, and the discharged water needs to be treated in accordance with local laws and regulations.
- When constructing equipment foundations, it is necessary to consider the cable outlet of the energy storage system and to reserve a trench or an inlet hole.
- The holes reserved for the foundation of the equipment and the holes in the bottom of the equipment

for incoming wires should be blocked.

- The foundation is made according to the foundation plan provided by ZCS, or the foundation plan confirmed by our company, and the tolerance of the upper surface of the foundation is required to be $\pm 3\text{mm}$.

4.2.2 Requirements for installation space

In order to ensure that the air inlet can be better air intake and maintenance, it is recommended to reserve enough space around the box installation position, the minimum space requirement is shown in the figure below:

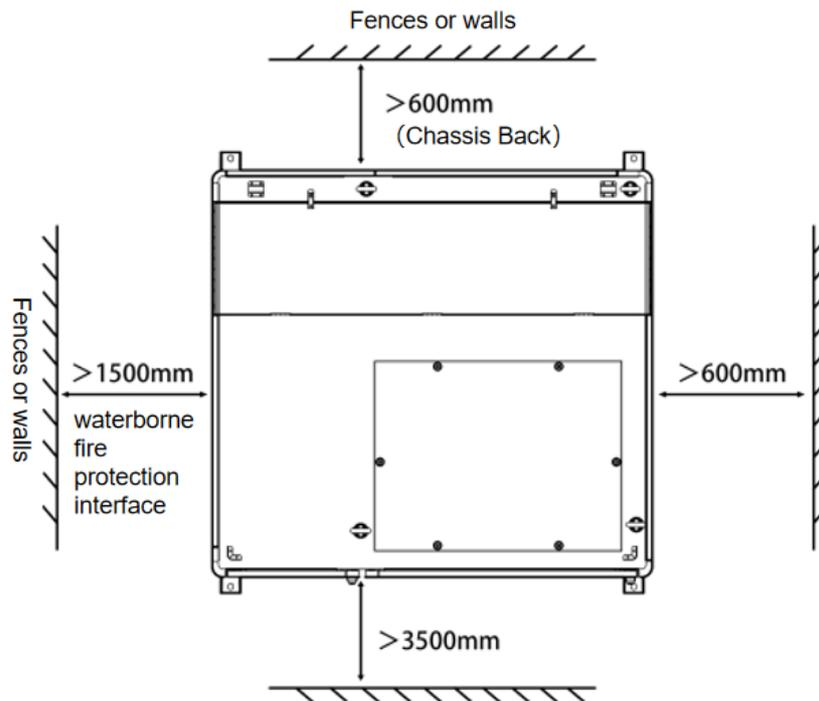

Figure 12 - Single Energy Storage group system installation

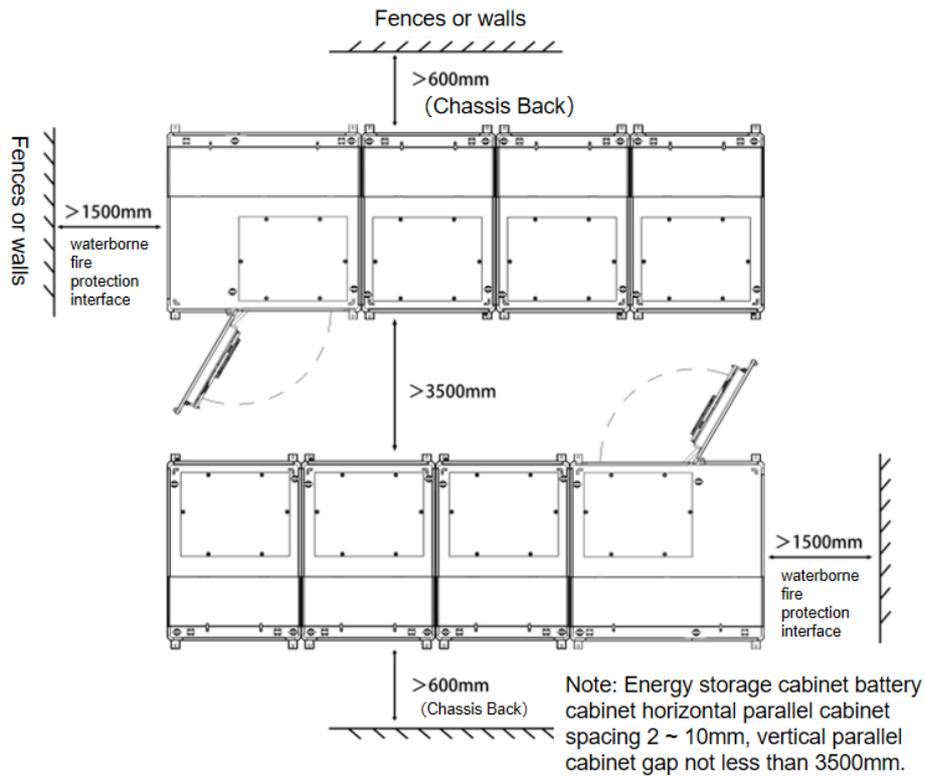

Figure 13 - Parallel cabinet (face to face)

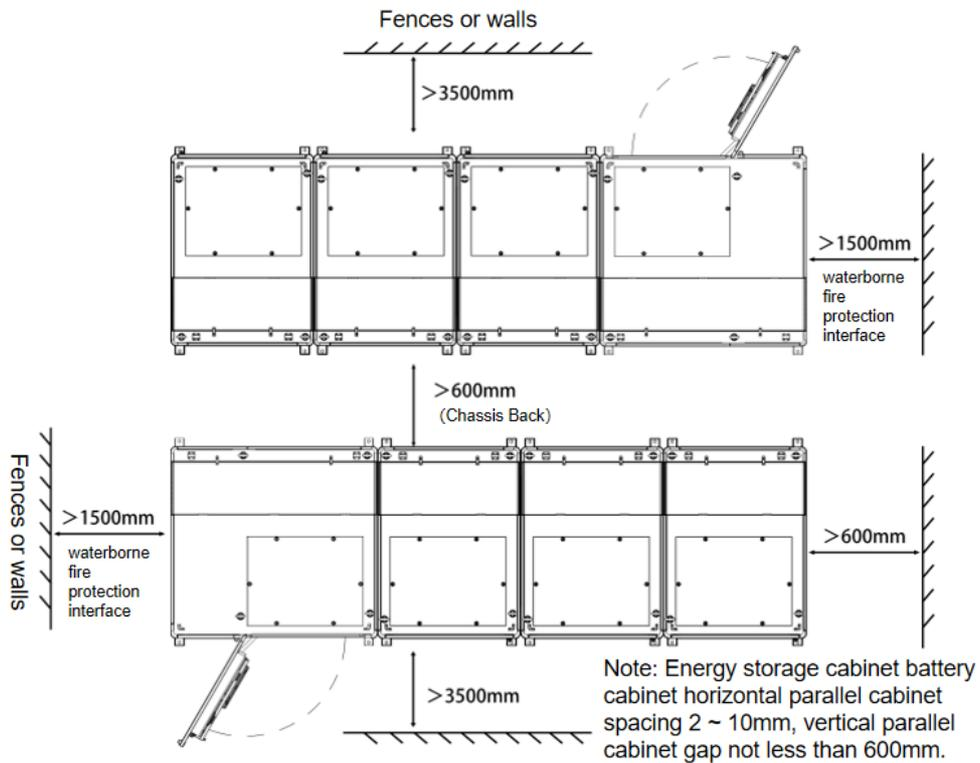

Figure 14 - Parallel cabinet (back to back)

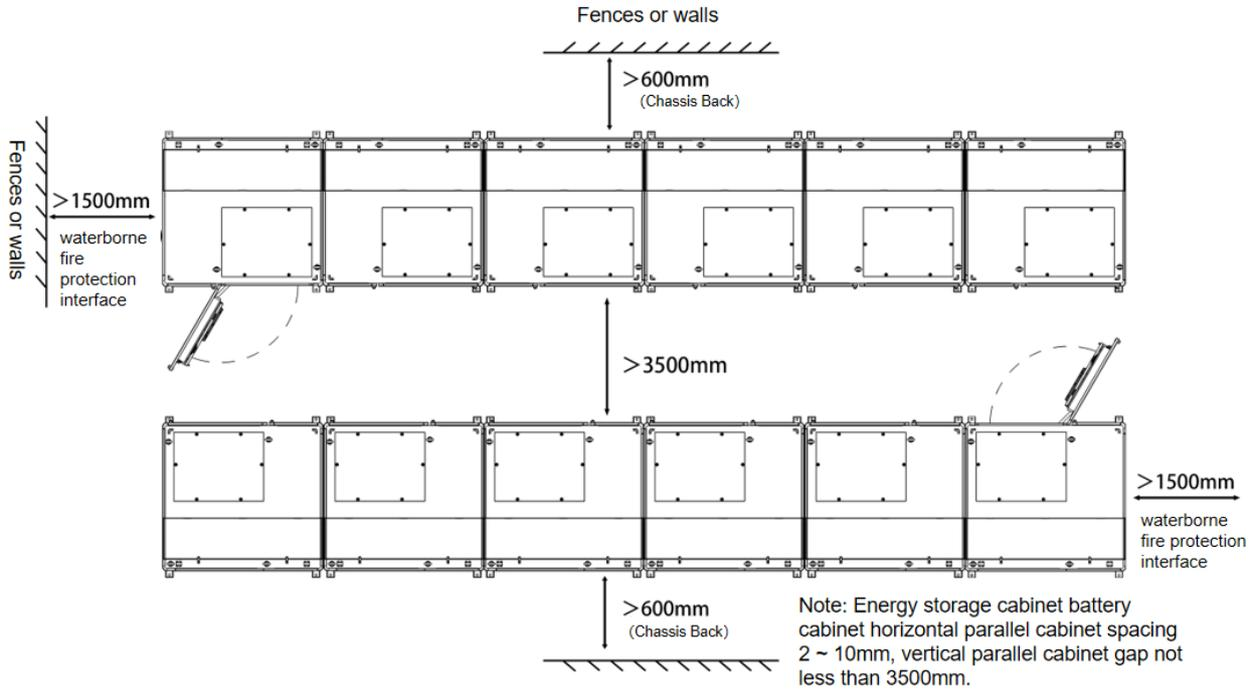

Figure 15 - Storage Cabinet parallel cabinet installation (face to face)

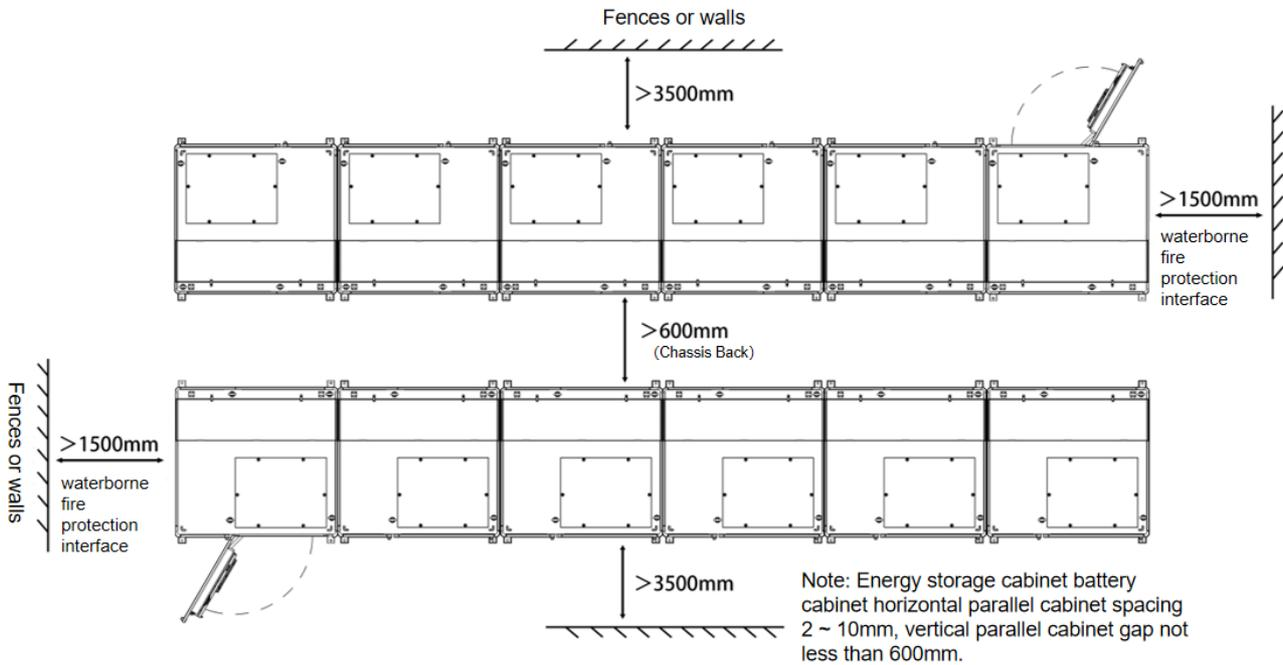

Figure 16 - Storage Cabinet parallel cabinet installation (back to back)

If the waterborne fire protection interface is not used, then the side distance can be reduced to 600mm.

4.2.3 Recommended foundation drawings

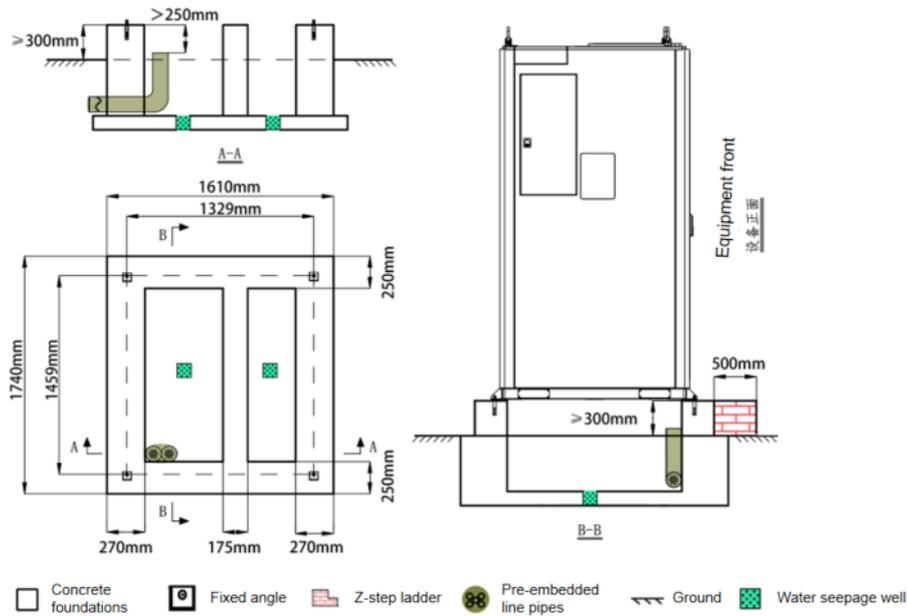

Figure 17 – Single energy storage cabinet foundation

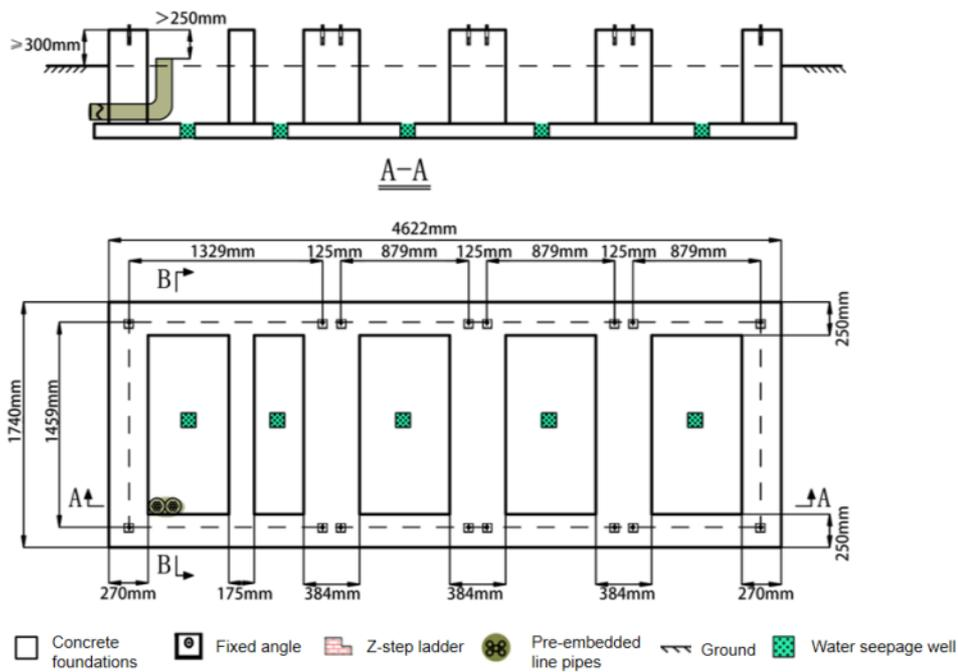

Figure 18 – 1 energy storage cabinet + 3 battery cabinets foundation

The above diagram is only a simple schematic, more detailed foundations should be made in accordance with the foundation drawing provided by ZCS or the foundation plan should be confirmed by ZCS.

4.2.4 Optional customized steel base

The optional steel base is only available for energy storage cabinet and battery cabinets parallel connection scheme to keep all the cabinets in the level. All the cabinets are fixed to the base by screws.

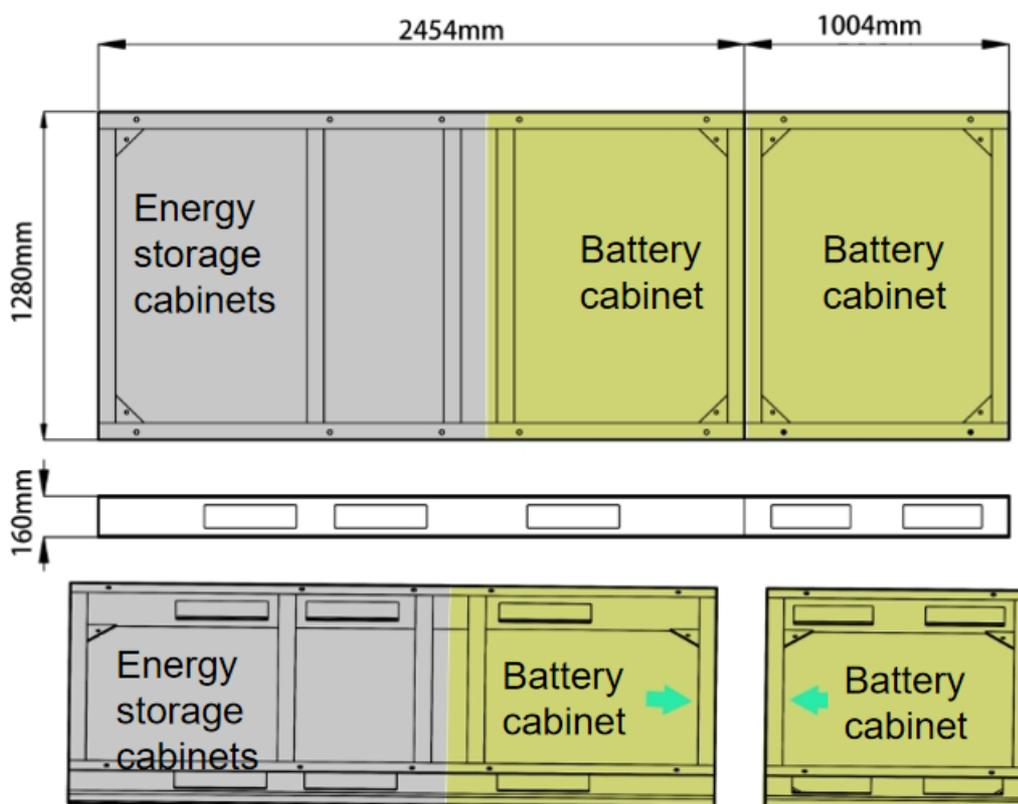

Figure 19 - Optional steel foundation

4.3 Hosting and fixing

4.3.1 Preparation tools

	The handles of tools used, including socket wrenches, torque spanners, screwdrivers, etc., need to be insulated or insulated tools used.
Attention	

Preparation tools

The tools to be prepared before the installation of the equipment are as follows.

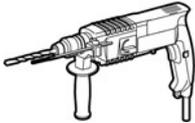
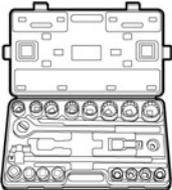
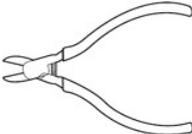
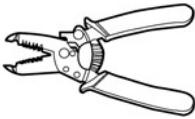
			
Hammer drill (drill bit : Φ14mm、 Φ16mm)	Torque socket wrench	Torque controlled wrench	Diagonal pliers
			
Wire strippers	One word screwdriver Knife head :0.6mm× 3.5mm	Rubber mallet	Utility knife

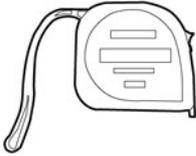
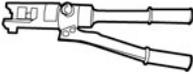
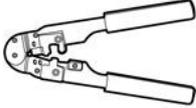
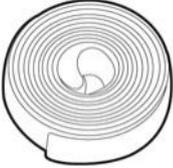
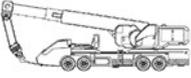

 Marker	 Steel measuring tape	 Level	 Hydraulic tong
 Cable cutter	 Crystal head clamp	 Vacuum clear	 Multimeter DC voltage range \geq 1500V DC
 Heat-shrinkable sleeve	 Heat gun	 Tie-line belt	 Insulation ladder
 Crane	 Lifting rope		



Personal protection tools

 <p>Safety gloves</p>	 <p>Safety goggles</p>	 <p>Dust mask</p>	 <p>Safety boots</p>
 <p>Reflective waistcoat</p>	 <p>Safety helmet</p>	 <p>Field medical chest</p>	

4.3.2 Check before installation

Inspection of deliverables

Check the completeness of the deliverables against the accompanying packing list.

Inspecting equipment

- Check whether the cabinet actually received is consistent with the ordered model.
- Inspect the energy storage system and internal equipment to ensure that there is no damage, such as holes, cracks, or other signs of possible internal damage.
- If you find a problem or have questions or if the unit model does not match, contact your dealer.

4.3.3 Installation and fixing work

	<p>Only a complete energy storage system without any damage can be installed!</p>
<p>Warning</p>	

Prerequisites:

- Before installation, make sure that the crane, sling, forklift, etc. meet the load-bearing requirements;
- Preparation of steel cables for lifting has been completed;
- Foundations have been constructed as required;
- Meet the weather requirements for lifting and forklift transport; when installing outdoors, lifting work should be stopped in case of bad weather conditions, such as heavy rain, fog, strong winds, etc.

Installation considerations:

Installation process	Warning
<p>Before installation</p>	<p>The lifting capacity of the crane is more than 6t and the working radius is not less than 5m; the carrying capacity of the forklift truck is $\geq 4t$. If the working conditions at the site do not meet the requirements, it is necessary to find a professional to carry out an assessment.</p>
	<p>Personnel carrying out forklift transport and lifting operations are required to undergo relevant training and be qualified before taking up their duties.</p>
	<p>Forklifts and lifting tools need to be inspected and qualified, and tools are complete before use.</p>
	<p>Ensure that the lifting tool is securely fixed to a load-bearing fixture or wall.</p>
	<p>Confirm that the crane and cable meet the requirements before lifting.</p>
	<p>The doors of the energy storage cabinets are all closed and locked.</p>

	Ensure that the steel cable is connected safely and reliably.
	A left-to-right or right-to-left lifting sequence is recommended to ensure smooth lifting.
Installation	It is strictly prohibited for unrelated persons to enter the forklift truck transport area, lifting area, and to stand under the boom.
	Ensure that the crane is in the right position and cannot be lifted for long distances.
	Keep smooth, the cabinet diagonal tilt $\leq 5^\circ$.
	Ensure that the angle between the two lifting cables is $<60^\circ$.
	Forklift trucks transport and lift equipment gently, lift the equipment slowly, and the energy storage system should be lifted slowly and smoothly to avoid impact on the internal equipment.
	When the energy storage system is in contact with the concrete support platform, wait until the four support force surfaces are relatively uniform before removing the lifting cable and forklift arm.
	It is prohibited to drag the wire rope and spreader, and prohibited to use hard objects to hit.

Operating steps

Step 1

Determine the base points of the energy storage system installation on the concrete support platform and record the base points with a marker. Based on the mounting base points, draw the locations of the four corner pieces of the energy storage system using an inkwell and a long leather tape measure.

Step 2

Remove the wrapping film, pearl cotton, and corner protection paper from the outside of the unit.

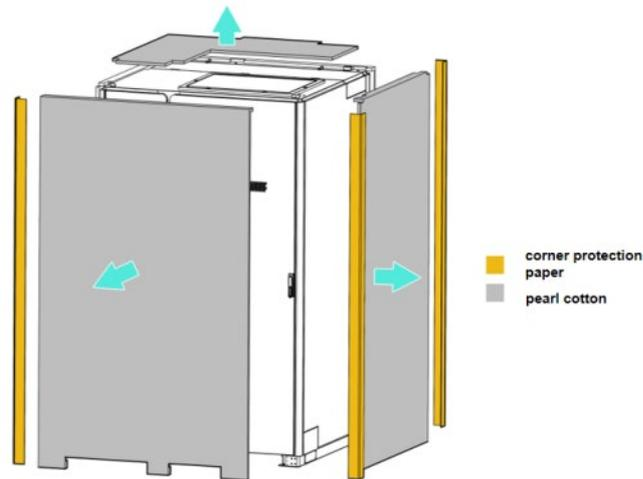

Figure 20 - Unpacking scheme for Energy Storage Cabinet

Step 3

Adjust the direction of the energy storage system to be consistent with the set installation direction, use a forklift truck to fork onto the concrete support platform, or connect the lifting cable to lift the energy storage system onto the concrete support platform. When installing the energy storage system, it must be ensured that the base of the energy storage system coincides with the base position drawn on the concrete support platform.

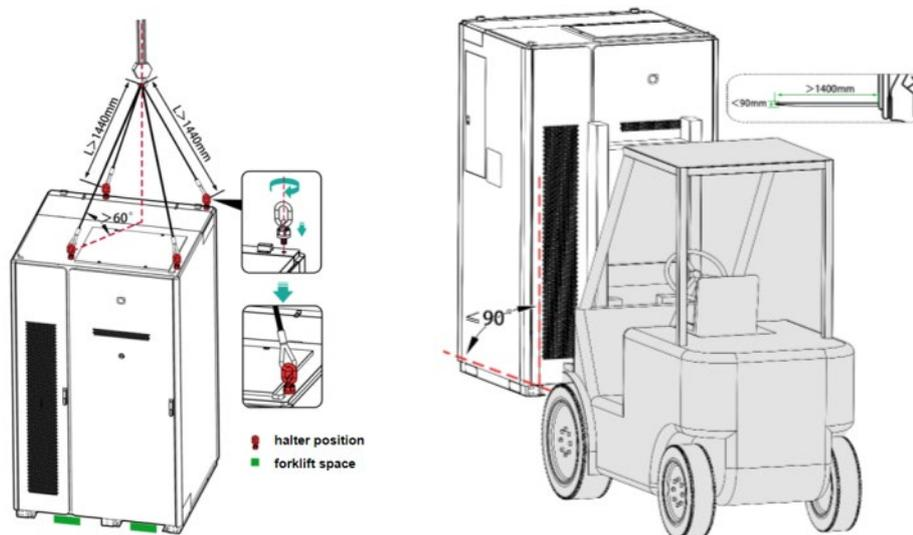

Figure 21 - Lifting and transportation

Step 4

Remove the shield by cutting through it with a utility knife. Remove the mounting parts supplied with the box. After opening the door, please check the delivered parts and quantity according to the Packing List, if there are any missing parts, please contact your dealer as soon as possible.

Step 5

Fix the energy storage system to the base or foundation.

	<p>When using a forklift truck to move the equipment, please tie down and secure it according to the actual situation to ensure that there is no risk of the equipment tipping over.</p>
<p>Warning</p>	

	<p>The energy storage system has been protected during transport by the addition of guards to protect the energy storage system.</p>
<p>Note</p>	

	<p>When hoisting the energy storage system, it is necessary to ensure that the four corners of the energy storage system coincide with the corners drawn on the concrete support platform.</p>
<p>Attention</p>	<p>There are four mounting holes at the contact between the Angle steel and the base, which should be drawn when marking the mounting holes.</p> <p>Each Angle steel shall ensure that there are two installation holes fixed. When drilling, two installation holes on the outside shall be preferred. When the drilling drill interferes with the reinforcement in the base concrete, the inner installation holes shall be selected.</p> <p>When fixing the angle steel and the base, make sure that the expansion bolts are tightened.</p>

Checklists

After the lifting of the energy storage system is completed, a post-installation inspection is required to ensure normal use and smooth subsequent installation.

No.	Check the content	Inspection method	Inspection standards
1	Are the bolts and nuts tight?	Use a spanner to tighten again.	Bolts and nuts are tightened.
2	Does the energy storage system door open and close properly?	Perform an open and close energy storage system door operation.	All doors of the energy storage system can be opened and closed smoothly.

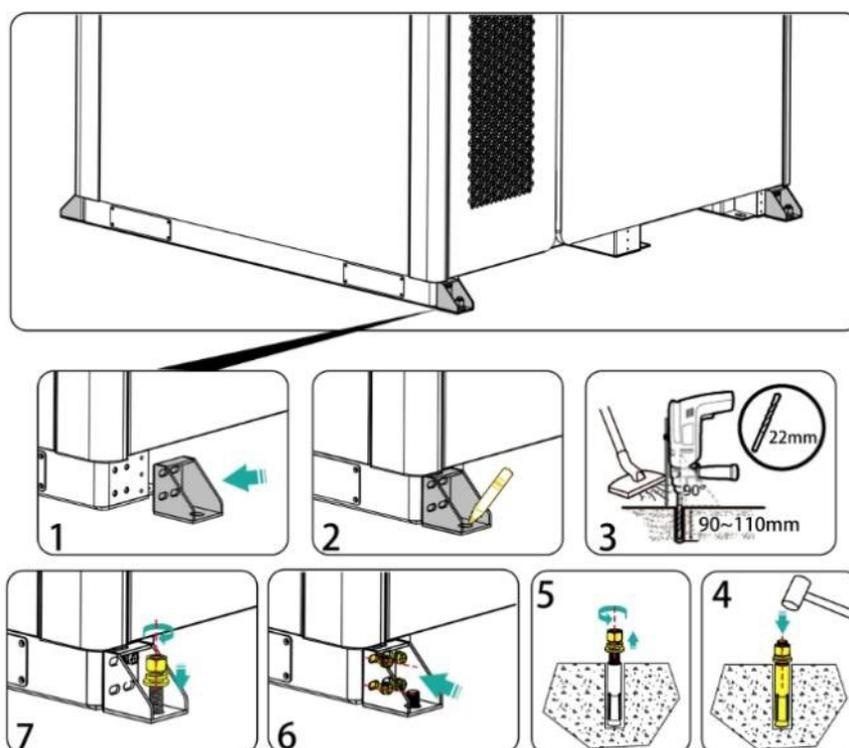

Figure 22 - Angle steel fixed for energy storage system

Step 6

Open the liquid cooling compartment to remove the base front and rear sealing plates and lock them into place on the base.

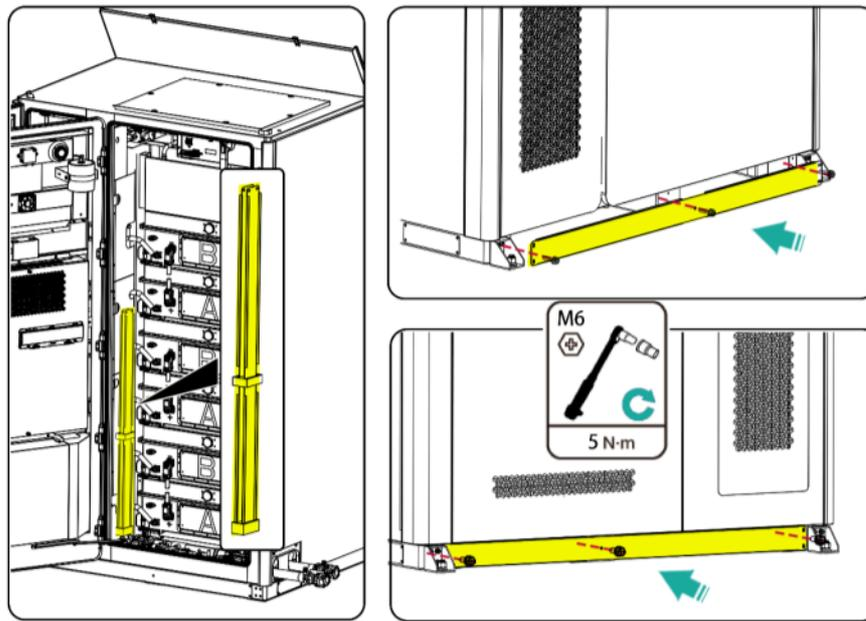

Figure 23 – Schematic diagram of the installation of the front and rear sealing plate

4.3.4 Fixed operation of cabinets connection scheme

Step 1

After making sure that the energy storage cabinet has been installed in the preset position, remove the long fixing angle piece shipped with the box, attach one end of the fixing angle piece to the mounting holes on the base of the energy storage cabinet and lock the screws.

Step 2

The locked fixed corner piece is taken as the positioning part, and as a reference, lift the battery cabinet along the direction of the positioning piece, so that the battery cabinet can fully fit the energy storage cabinet and the fixed corner parts, and complete the lifting.

Step 3

Repeat step 2 above to secure the energy storage system sequentially using the remaining angles after all battery cabinets have been lifted to the place.

Note: The illustration shows 1PCS energy storage cabinet + 3PCS battery cabinet parallel cabinet scheme.

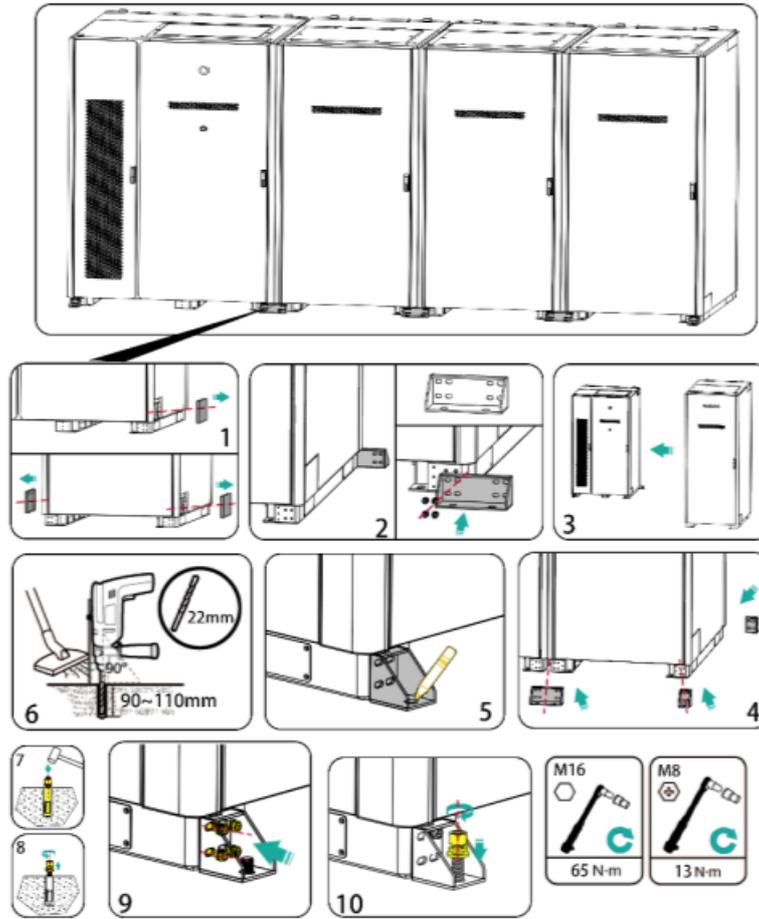

Figure 24 – Installation scheme of energy storage cabinet and battery cabinet connection

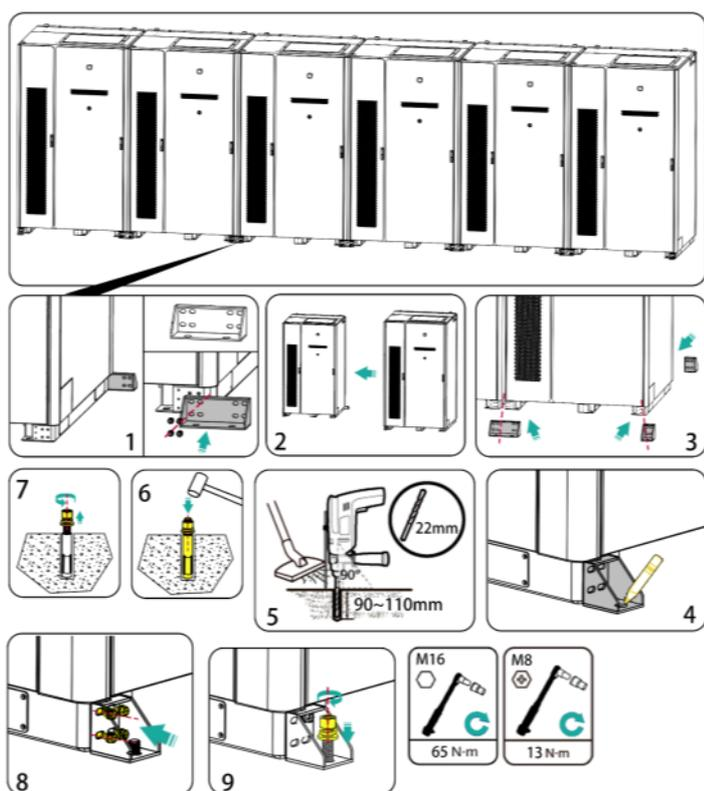

Figure 25 - Schematic of the installation of energy storage cabinets connection

4.3.5 Customized steel base installation

Step 1

Lift or forklift the steel base into position and make sure that the "Front" side of the steel base is in the same direction as the preset door opening;

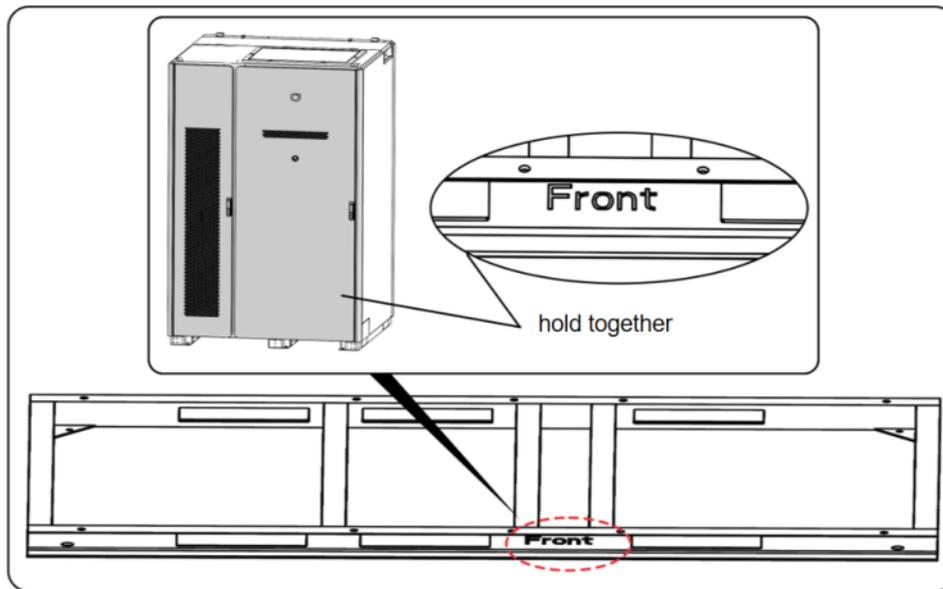

Figure 26 – Schematic diagram of steel base

Step 2

Use expansion bolts to fix the steel base with the cement floor. If the parallel cabinet scheme of n (n value is 1, " n " indicates the number of energy storage cabinets) + m (m value is 1~3, " m " indicates the number of battery cabinets) is adopted, it is preferred to fix the steel base for extra battery cabinet and level it before carry out the overall cabinet lifting operation.

Step 3

Use the bolts to fix the energy storage cabinet, the battery cabinet and the steel base firmly.

Step 4

Remove the sealing plate and block the front and back of the equipment base.

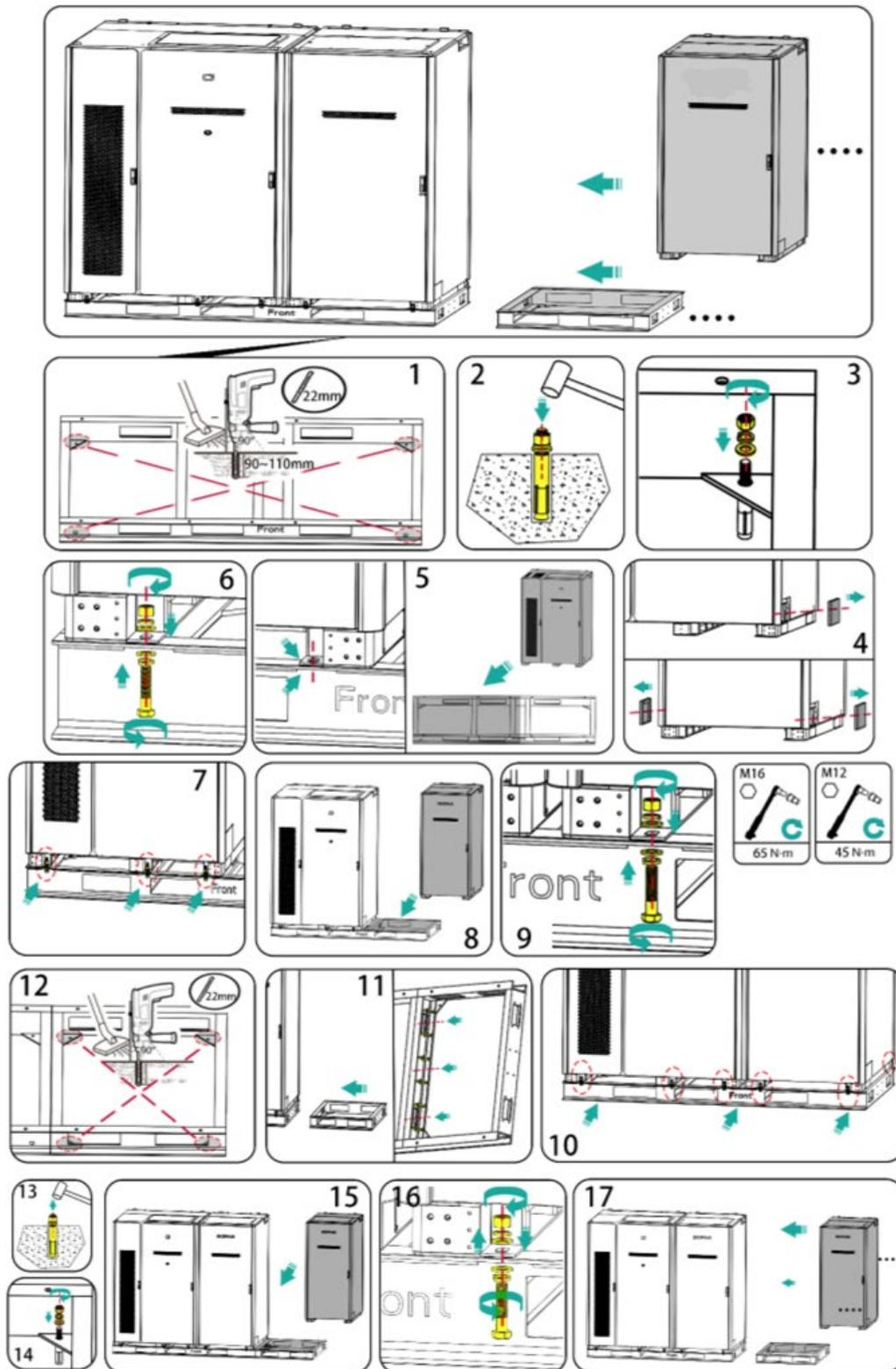

Figure 27 - Installation diagram of steel base solution

5. Electrical connections

	<p>Danger of high voltage! Danger of electric shock!</p> <p>Do not touch electrically charged parts !</p> <p>Please make sure that the AC and DC sides are not charged before installation.</p> <p>Do not place the device on flammable surfaces.</p>
Danger	

	<p>Before wiring, check and ensure that the polarity of all input cables is correct.</p> <p>During electrical installation, do not forcibly pull any wires or cables, as this may compromise the insulation performance.</p> <p>Ensure that all cables and wires have sufficient space for any bends.</p> <p>Adopt the necessary auxiliary measures to reduce the stress applied to cables and wires.</p> <p>After completing each connection, carefully check and ensure that the connection is correct and secure.</p>
Warning	

5.1 Safety precautions

5.1.1 Wiring requirements

- Cable selection, erection and routing must follow local laws, regulations and codes.
- In the process of laying out the power supply line, it is strictly prohibited to make loops or twists. If the length of the power cord is found to be insufficient, the power cord must be replaced again, and it is strictly prohibited to make joints or welding points in the power cord.
- All cables must be securely connected, well insulated, and of the proper gauge.
- Cable grooves and crossing holes should be free of sharp edges, and the location of cable penetration pipes or crossing holes should be protected to avoid damage to the cables by sharp edges, burrs, and so on.

- Cables of the same type should be tied together, straight and neat in appearance, without outer skin damage; cables of different types should be placed at least 30mm apart, and it is prohibited to entangle or cross-lay each other.
- When wiring is completed or when leaving during wiring, immediately seal the cable opening with sealing mud to avoid water vapour and small animals.
- Buried cables need to be reliably fixed with cable holders and cable clamps, and cables in the backfilled area should be ensured to fit tightly with the ground to prevent deformation or damage to the cables caused by the force of backfilling.
- When external conditions (e.g., laying method or ambient temperature, etc.) change, cable selection should be verified by reference to IEC-60368-5-52 or local codes and regulations, e.g., whether the current-carrying capacity meets the requirements.
- Cables used in high temperature environments may cause deterioration and breakage of the insulation, and the distance between the cable and the periphery of the heat generating device or heat source area should be at least 30mm.
- When the temperature is too low, violent shocks and vibrations may cause brittle cracking of the plastic sheath of the cable. To ensure safe construction, the following requirements should be followed:
- All cables should be laid and installed above 0°C. When handling cables, especially when working in low-temperature environments, they should be handled gently.

5.1.2 Short Circuit protections

- When installing and maintaining the battery PACK, it is necessary to wrap the exposed cable terminals on the battery with insulating tape.
- Avoid foreign objects (such as conductive objects, screws, liquids, etc.) from entering the inside of the battery and causing a short circuit.

	<p>Before making electrical connections, make sure the device is undamaged or it may cause electric shock or fire.</p>
<p>Danger</p>	<p>Unregulated and incorrect operation may cause accidents such as fire or electric shock.</p> <p>In the process of operation, it is necessary to prevent foreign matter from entering the</p>

	equipment, otherwise it may lead to short circuit failure or damage of the equipment, load supply. Electricity down or power down, and personal injury.
--	---

	When installing equipment that requires grounding, the protective ground wire must be installed first; when removing equipment, the protective ground wire must be removed last.
Warning	
	No cables are allowed to pass through the air inlet or outlet of the equipment to avoid obstruction.
Attention	

5.1.3 Grounding requirements

- The ground impedance of the device must meet the requirements of the local electrical standards.
- The equipment should be permanently connected to a protective ground. Before operating the equipment, check the electrical connections of the equipment to ensure that it is reliably grounded.
- Do not operate the device without a ground conductor installed.
- Do not damage the ground conductor.
- For equipment using three-pronged sockets, it must be ensured that the ground terminal in the three-pronged socket is connected to the protective ground.
- For a device with high contact current, ground the protective grounding terminal of the device cover before connecting the input power to prevent electric shock caused by the contact current of the device.

5.1.4 Antistatic requirements

The static electricity generated by the human body may damage the electrostatic sensitive components on boards, such as the large-scale integrated circuit (LSI).

- When touching the equipment, before holding a single board, a module with exposed circuit boards, or a dedicated integrated circuit (ASIC) chip, etc., please observe the static protection specification, and wear

anti-static overalls, anti-static gloves or wristbands, and the other end of the anti-static wristbands should be well grounded.

- When holding a board or a module with an exposed circuit board, hold the edge of the board or module without components. Do not touch the components with your hands.
- The removed boards or modules must be packaged in anti-static wrapping material before storage or transport.

5.2 Wiring preparation

5.2.1 Preparation of installation tools

			
Safety gloves	Protective eyewear	Safety shoes	Protective clothing
			
Torque Screwdriver	Peeler Pliers	Hydraulic Pliers	Hot Air Guns
			
Multimeter	Screwdriver	Torque spanner	Scissors
			

Crimping pliers	Cutting pliers	Netting pliers	Fibre optic stripper
-----------------	----------------	----------------	----------------------

5.2.2 Preparation of cables

Name	Type	Scope of cross-sectional area selection	Terminal	Remarks
The PCS AC input power cord	3 core (A, B, C) outdoor copper core wire or choose armored cable	95mm ² *3	The M 8 OT / DT terminal	Storage cabinet PCS AC input three-phase power line
Auxiliary power supply AC power supply line (external power grid power supply)	3-core (L, N, PE) outdoor copper core wire	16mm ² *3	The M 6 OT / DT end Sub (terminal width <18mm)	
DC-parallel cabinet power line	Random cabinet comes with it	DC+:70mm ² DC-:70mm ²	The cable comes with a power terminal	Energy storage cabinet and battery cabinet when used
Connection cabinet signal line	Random cabinet comes with it	—	—	Energy storage cabinet and battery cabinet when used
RS485 communication line	2 Core shielding line	(0.5~1.5mm ²) *2	Tube type cold pressure end + specified pin	Choose according to the actual configuration
CMU communication network line	CAT 5E Outdoor shielded network cable, with an internal resistance of 1.5 Ω / 10m	—	Shield of the RJ 45 crystal head	When the energy storage cabinet does not integrate CSU, CMU to CSU

CSU communication network cable	CAT 5E Outdoor shielded network cable, with an internal resistance of 1.5 Ω / 10m	—	Shield of the RJ 45 crystal head	When the energy storage cabinet is integrated with the CSU, the CSU goes to the industrial controller
I / O dry contact signal line	4 core line, 8 core line, 14 core	(0.5~1mm ²) *4 (0.5~1mm ²) *8 (0.5~1mm ²) *14	Tube type cold pressure end + specified pin	Choose different number of core wires according to the actual configuration
24V power cord	2 Core line	16AWG*2	Tube type cold pressure end + specified pin	Choose according to the actual configuration
Three-phase AC voltage sampling line	3 Core line	16AWG*3	Tube type cold pressure end + specified pin	Choose according to the actual configuration
Protect the grounding wire	Single-core outdoor copper core wire or grounding flat steel	Copper core wire: (25mm ² ~50mm ²) or ground flat steel: (section (40mm 4mm))	The M10 OT / DT terminal	The specific size of the grounding wire / flat steel is subject to the design of the design institute.

	<p>The cables used should comply with local laws and regulations.</p> <p>The cable colours involved in the illustrations in this manual are for reference only, please select cables according to local cable standards.</p> <p>The diameter of the cable must be selected in accordance with the maximum load capacity and the length must be allowed for.</p> <p>All DC input cables should be of the same specification and material.</p> <p>PCS AC input cable, auxiliary power supply AC power cable usually need to be prepared by the customer, and the rest of the cables will be prepared by ZCS</p>
Attention	

5.2.3 Cable compression and connection

OT/DT terminal crimping

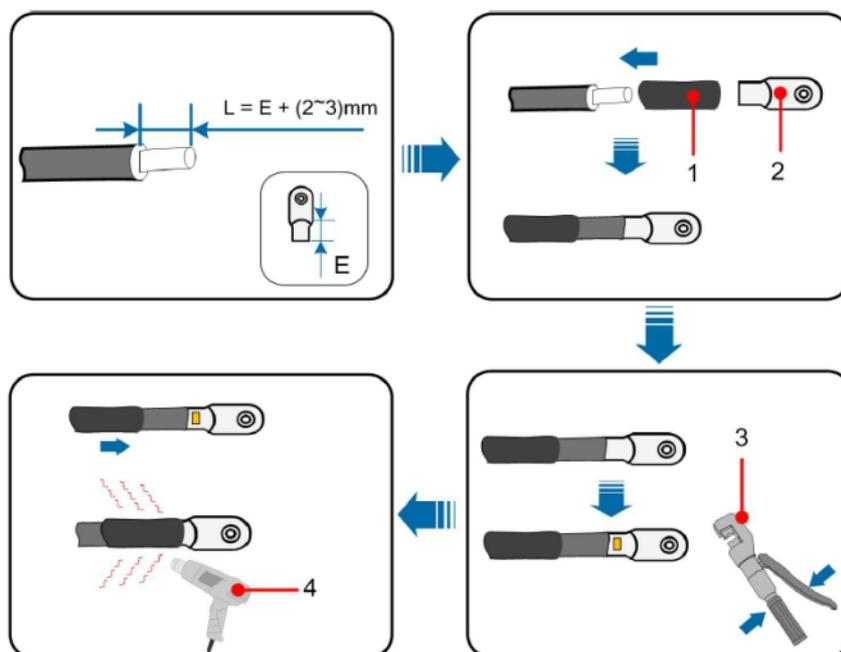

(1) Heat Shrinkable Tubing (2) OT/DT Terminal

(3) Hydraulic pliers (4) Hot air gun

Figure 28 - OT/DT Terminal crimping

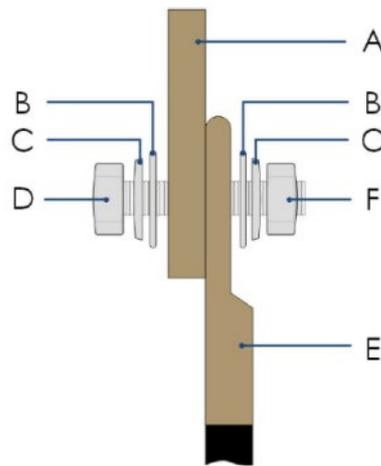

Figure 29 – Cable connection

No.	Name	Serial number	Name
A	Copper row	D	Bolt
B	Flat pads	E	Copper Terminal Block
C	Spring pads	F	Nuts

5.2.4 Open the cabinet doors and equipment compartment doors

Step 1

Open the door of the energy storage cabinet and battery cabinet, move the cover of the door lock hole to the top of the lock hole with the key and rotate. After the door handle pop up and rotates clockwise, open the cabinet door.

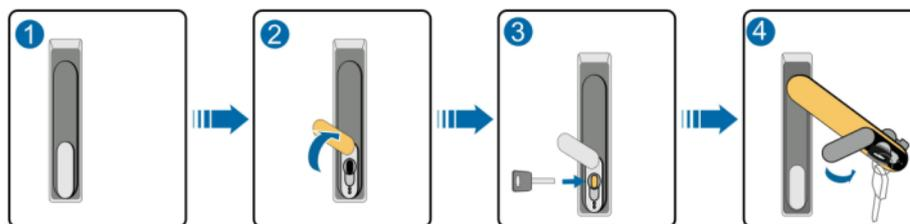

Figure 30 – Opening cabinet door

Step 2

When the cabinet door is opened, the double-headed bolt of the door support will slide naturally. When the double headed bolts slide into the holes (Fig. A), the limiting bar will be fixed automatically.

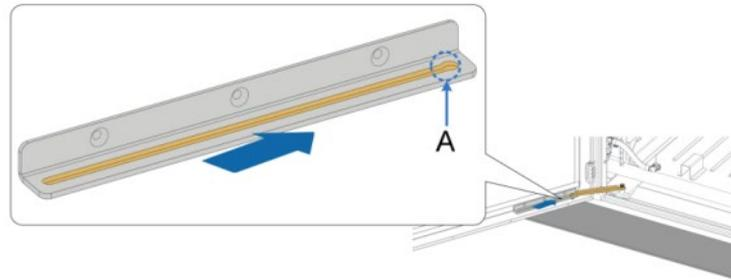

Figure 31 - fixed cabinet door

*The above pictures are for reference only, please refer to the actual product you received !

Step 3

Remove the top sealing plate of the energy storage cabinet and the battery cabinet.

5.2.5 Cable entrance design

The connection cables between the energy storage cabinet and external equipment are uniformly fed in and out from the bottom of the cabinet. The parallel cabinet cable of the energy storage cabinet and the battery cabinet enters and exits from the top of the cabinet. All cables pulled out of the cabinet need to be well protected, such as laying through the pipe, in order to prevent rodents from damaging the cables. At the end of the wiring work, the energy storage cabinet inlet and outlet holes should also be fire clay or other suitable materials sealed tightly. The design of the cable access holes at the bottom of the energy storage cabinet is shown in the following diagram.

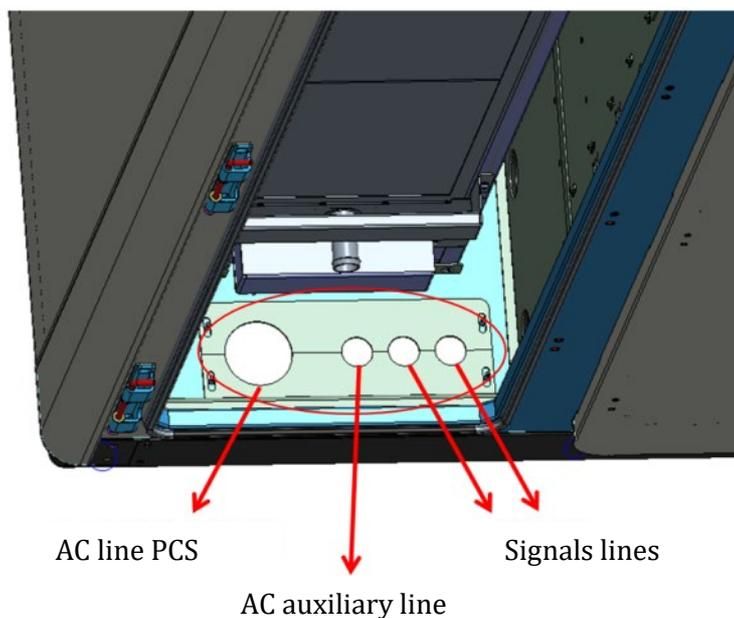

Figure 32 – Cable entry and exit holes at the bottom of the energy storage cabinet

*The above pictures are for reference only, please refer to the actual object received

5.3 Ground connection

There are two kinds of grounding methods: fixed with grounding flat steel or fixed by grounding cable.

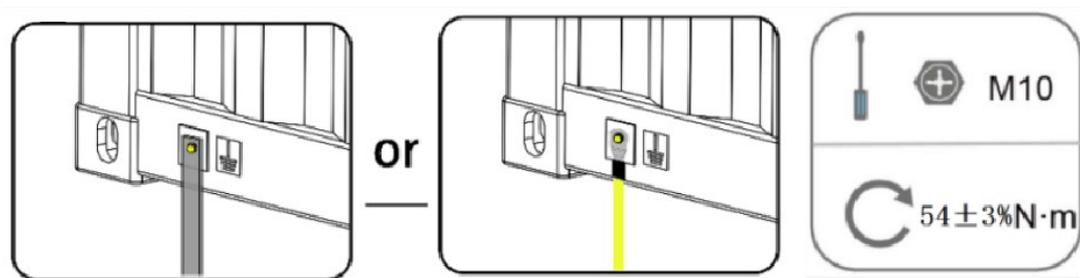

Figure 33 – Cabinet grounding

*The above pictures are for reference only, please refer to the actual product you received

Ground flat steel

Fix the grounding flat steel to the two grounding points of the energy storage and battery cabinet base with M10x30 screws, the whole fixing surface needs to be sprayed after completion.

Grounding cable

Use a 25 mm² to 50 mm² grounding cable to reliably connect the two grounding points of the energy storage cabinet and the battery cabinet to the grounding point of the grounding grid on site.

The cable is crimped to the DT terminal and when crimping is complete, it is tightened using M10x30 screws.

Please take into account the actual situation of the project site and follow the instructions of the power station staff to install the external grounding. The grounding resistance shall be measured after the grounding connection is completed, and the resistance value shall not be greater than 4 Ω.

	<p>Specific grounding resistance values are subject to relevant national/local standards and regulations.</p>
<p>Attention</p>	

5.4 Cable wiring between cabinets

The parallel cabinet cable wiring only happens when the energy storage cabinet and the battery cabinet are connected together. The cabinet cables wiring including DC power cable wiring and signal cable wiring, and these cables are shipped with the cabinets and has plug-in connection .

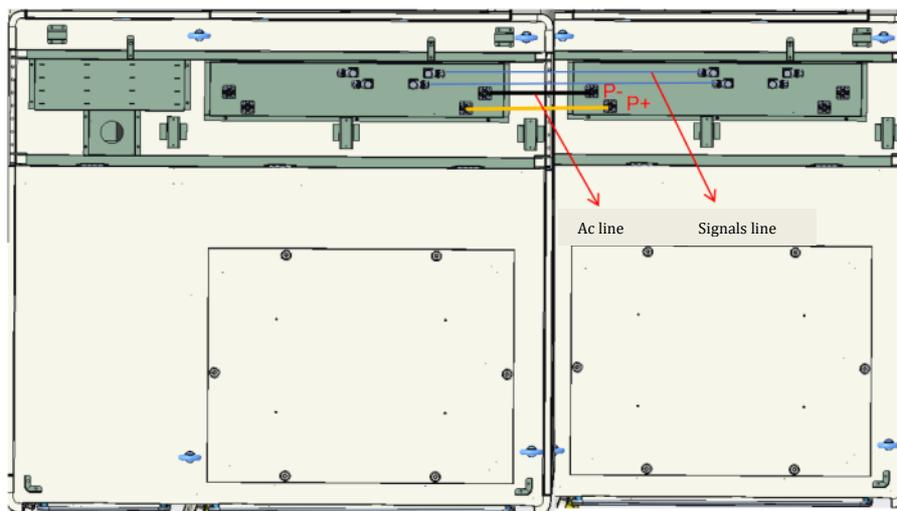

Figure 34 – Cable wiring between energy storage cabinet and battery cabinet

Procedure

Step 1

Locate the parallel cable that comes with the random cabinet, containing two power cables (one positive and one negative, with plugs at both ends) and two sets of signal cables (with signal terminals at both ends).

Step 2

Plug the power and signal cables into the energy storage cabinet first, make sure the terminals have been plugged into place and locked, and then according to the cable identification, lead them to the corresponding interface wiring of the battery cabinet of the parallel cabinet.

Step 3

After all the cables of the parallel cabinet are connected, tie the cables to fix them, and check whether the plug is plugged in place again. (Judgement method: 1, can hear the sound of installation in place, 2, reverse pull the cable without loosening)

Step 4

When wiring is complete, gently tug on the cable to ensure that margin is left.

Step 5

Install the cable guard cover

5.5 PCS AC power cord connections

The PCS AC power cable wiring is located on the input side of the three-phase AC moulded case circuit breaker in the junction box in the liquid-cooled compartment of the energy storage cabinet. The AC power line wiring is shown below.

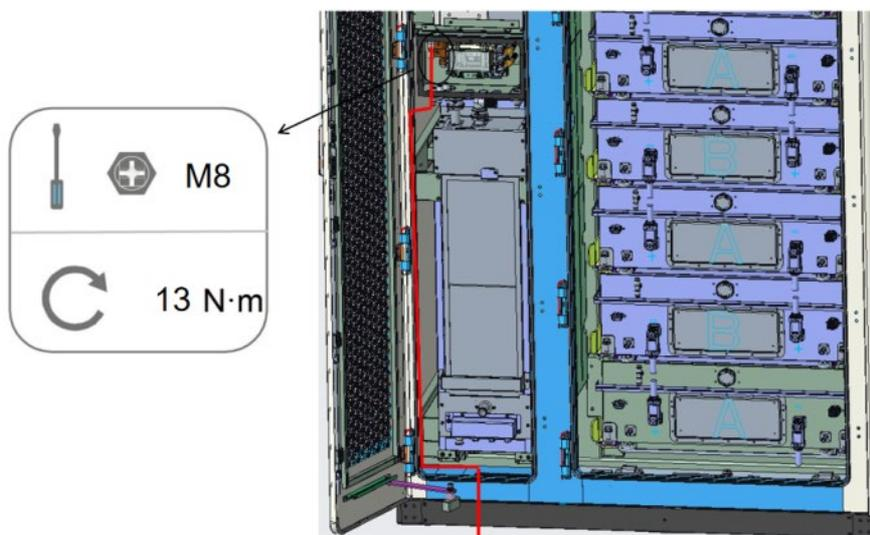

Figure 35 - PCS AC cable laying

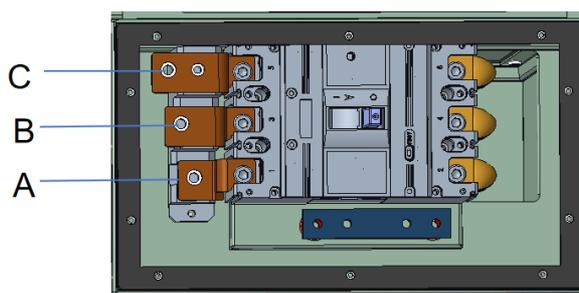

Figure 36 - PCS AC cable input switch phase sequence (adding circuit breaker row N)

Operating procedure

Step 1

Disconnect the front AC circuit breaker and measure with a multimeter to determine that there is no voltage on the power line leading to the energy storage cabinet.

Step 2

Pass the cable through the inlet hole at the bottom of the energy storage cabinet and lead it to the corresponding wiring position according to the cable identification.

Step 3

Cut excessively long cables with wire cutters.

Step 4

Use wire pers to strip the cable cover and expose the copper core.

Step 5

For compression of OT terminals, please refer to "5.3.3 Cable compression and connection".

Step 6

With the M6 bolt, secure the OT terminal to the wiring hole.

Step 7

When wiring is complete, gently tug on the cables to ensure that there is margin, and tie off the cables with cable ties according to the alignment path.

	<p>The PCS AC input power cord must be wired strictly according to the terminal phase sequence.</p>
Attention	

5.6 Signal terminals wiring

There are signal terminals on the energy storage cabinet and no external wiring port on the battery cabinet, which are mainly used for IO signal transmission, CAN communication, 485 communication, 24V power supply and voltage sampling signal transmission. There is a difference in the number and definition of external interfaces between the integrated CSU and the non-integrated CSU of the energy storage cabinet, the field should be wired according to the actual configuration and refer to the following interface definition table, and the wiring of external interfaces of the energy storage cabinet is shown in the figure below.



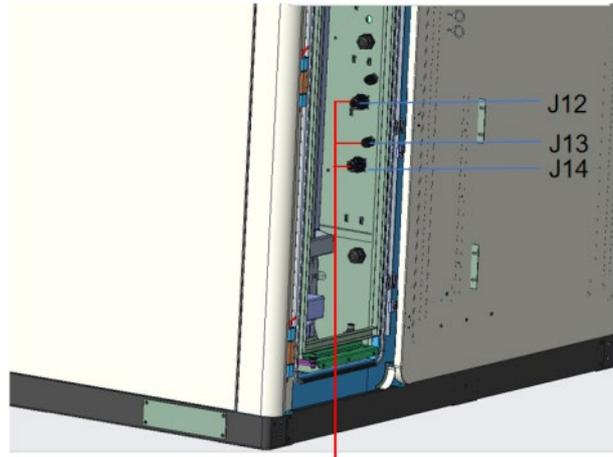

Figure 37 - External wiring of storage cabinet signal terminals

external interface terminal	Terminal Pins	Feet instructions	Recommended line diameter range	Remarks
J12	1~2	The CAN communication between the CSU and the PCS	(0.5~1.5mm ²) *8	
	3~4	Carrier synchronization between the CSU and the PCS		
	5~6	CSU alarm signal input to CMU		
	7~8	CMU alarm signal output to CSU		
	9~12	/	/	No wiring
	13~14	24V power supply for sink cabinet dehumidifier	16AWG*2	
	15~16	Confluence cabinet CSU 24V power supply	16AWG*2	
J13	1~2	External alarm signal input to CMU	(0.5~1.5mm ²) *8	Reserved interface, without wiring
	3~4	CMU output external fault		Pre-wired interface, no wiring required

	5~6	CAN communication between PCS and PCS		No wiring is required for this pin on a single storage cabinet.
	7~8	Carrier synchronisation between PCS and PCS		No wiring is required for this pin on a single storage cabinet.

external interface terminal	Terminal Pins	Feet instructions	Recommended line diameter range	Remarks
J12	1~2	CSU communicates with counter-current meter 485	(0.5~1.5mm ²) *16	
	3~4	CSU and backup cabinet		
	5~6	CSU and backup cabinet STS often open state detection		
	7~8	Detection of CSU and backup cabinet QF 3 switch		
	9~10	CSU and backup cabinet SPD1 state detection		
	11~12	CSU and backup cabinet SPD2 state detection		
	13~14	CSU with backup cabinet QF1 switch opening and closing status detection		
	15~16	Detection of CSU and backup cabinet QF 2 switch		
J13	1~2	External alarm signal input to CMU	(0.5~1mm ²) *8	Pre-wired interface, no wiring required
	3~4	CMU output external fault		Pre-wired interface, no wiring required
	5~6	Local management alarm signal input to CSU		
	7~8	CSU alarm signal output to local management		
J14	1~2	CSU control and backup cabinet STS closure	(0.5~1.5mm ²)	



	3~4	CSU control and backup cabinet switch QF1 closure	*8	
	5~6	CSU control and backup cabinet switch QF1 disconnection		
	7~8	CSU control and backup cabinet switch STS disconnection		
	9~10	The CSU draws 24V from the grid side of the backup cabinet.	16AWG*2	
	11~13	/	/	No wiring required
	14~16	CSU collects and disconnects grid-side line voltage from the cabinet	16AWG*3	

Operating procedure

Step 1

Find the matching plugs and pins for the terminals that come with the cabinet.

Step 2

According to the actual configuration of the system, according to the above table interface definition for the storage cabinet external signal terminal wiring, the cable through the bottom of the storage cabinet signal into the hole, according to the cable identification, lead to the corresponding terminal block plug pins for wiring.

Step 3

Cut excessively long cables with wire cutters.

Step 4

Use wire strippers to strip the protective coating from the cable to expose the copper core.

Step 5

Use crimping pliers to crimp the cable to the pins.

Step 6

Insert the wired pins into the corresponding pin holes of the plug in accordance with the wiring sequence of the interface definition table, and lock the signal wires with the crimp clips provided with the plug.

Step 7

After the wiring is completed, gently pull the cable to ensure the margin.

5.7 Communication cable connections

CMU communication line

If the CSU is not integrated in energy storage cabinet, perform this step. The external network cable is from the external CSU to go to the CMU of the energy storage cabinet, the communication network cable wiring location in the auxiliary power module output RJ45 port, the CMU communication network cable wiring as shown in Figure 5.12.

Step 1

Pass the communication network cable through the signal inlet hole at the bottom of the energy storage cabinet, and after passing through the PG header at the corresponding position of the liquid-cooling compartment of the energy storage cabinet, lead it to the corresponding wiring position of the auxiliary power module according to the cable identification.

Step 2

Cut off any excessively long cables with a network cable cutter.

Step 3

Use the network cable clamp to crimp the crystal head to the network cable, the network cable wire sequence at both ends of the uniform 568A standard or 568B standard can be.

Step 4

After crimping is complete, insert the crystal head into the RJ45 port of the Auxiliary Power Module.

Step 5

After the wiring is completed, gently tug on the cable to ensure that there is a margin, the corresponding PG header must lock the cable, and tie up the communication network cable according to the alignment path.

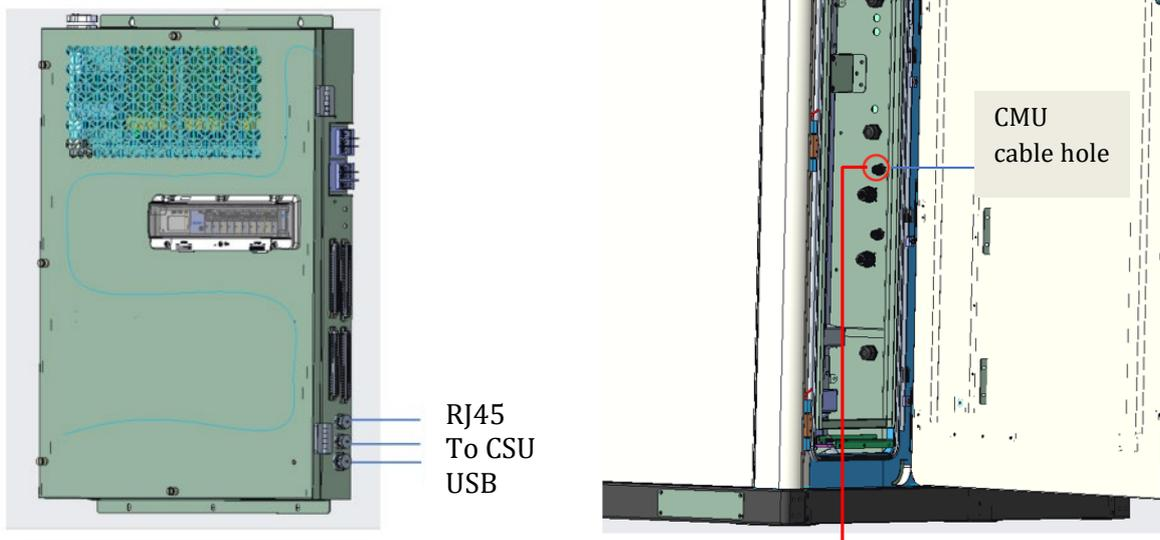

Figure 38 – CMU communication cable connection

CSU communication network cable

If the CSU is integrated in energy storage cabinet, perform this step. Then the external network cable is going from the host computer to the CSU of the energy storage cabinet, the communication network cable wiring position is at the RJ45 port of the CSU, and the communication network cable wiring of the CSU is shown in the following figure.

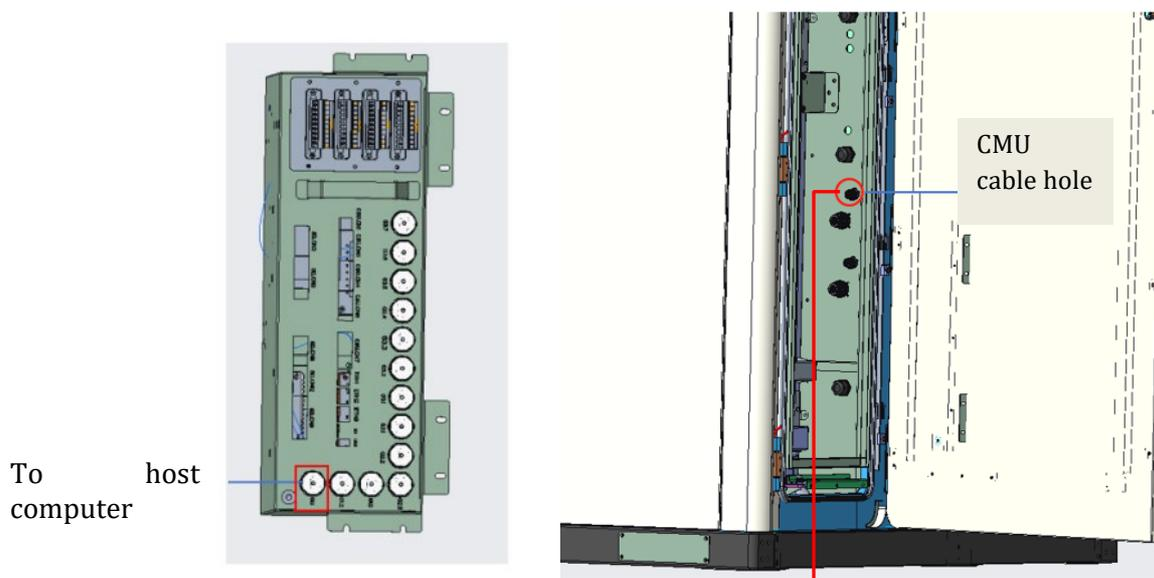

Figure 39 – CSU communication cable connection

Step 1

Pass the communication network cable through the signal inlet hole at the bottom of the energy storage cabinet, and after passing through the PG header at the corresponding position of the liquid-cooling compartment of the energy storage cabinet, lead it to the corresponding wiring position of the auxiliary power module according to the cable identification.

Step 2

Cut off any excessively long cables with a network cable cutter.

Step 3

Use the network cable clamp to crimp the crystal head to the network cable, the network cable wire sequence at both ends of the uniform 568A standard or 568B standard can be.

Step 4

After crimping is complete, insert the crystal head into the RJ45 port of the Auxiliary Power Module.

Step 5

After the wiring is completed, gently tug on the cable to ensure that there is a margin, the corresponding PG header must lock the cable, and tie up the communication network cable according to the alignment path.

5.8 Operations after cable wiring

After all cable wiring has been made, the following operations are also required:

Use fireproof and waterproof materials to tightly seal the outlet holes and gaps around the energy storage cabinet.

All wiring removed cover plates, door panels, and screws need to be reinstalled and restored.

	<p>If not properly sealed, moisture may enter.</p> <p>If not properly sealed, rodents may enter.</p>
<p>Warning</p>	

6. Piping of additional storage cabinets

	<p>Operation not in accordance with the requirements of this manual may void the warranty.</p>
<p>Caution</p>	

6.1 Preparing tools for Liquid cooling system piping

In order to correctly execute this procedure it is necessary to prepare the following tools:

- Liquid cooling pressure maintaining tool
- Liquid cooling coolant inject Tool (with compressor)
- Liquid coolant discharge pipe
- Cooling liquid

6.1.1 Sealing inspection of liquid cooling pipelines in cabinets

Before starting the installation of the liquid cooling pipelines for cabinet consolidation, the air tightness of each cabinet should be checked to ensure that the liquid cooling pipelines of the cabinets are not damaged during storage and transportation. If it is found that the air tightness of the cabinet does not meet the requirements during inspection, timely contact should be made with the after-sales service personnel. Due to the fact that the energy storage main cabinet is transported with liquid, it is sufficient to visually inspect all parts of the pipeline for any leakage, and there is no need for pressure testing. The following pressure test is only applicable to battery cabinets.

Step 1

Check and confirm that the ball valve of the cabinet is in a closed state (the handle of the ball valve is a parallel pipeline). Remove the cover and sealing ring at the right end of the first level pipeline of the cabinet to be inspected, and properly store the removed cover and sealing ring

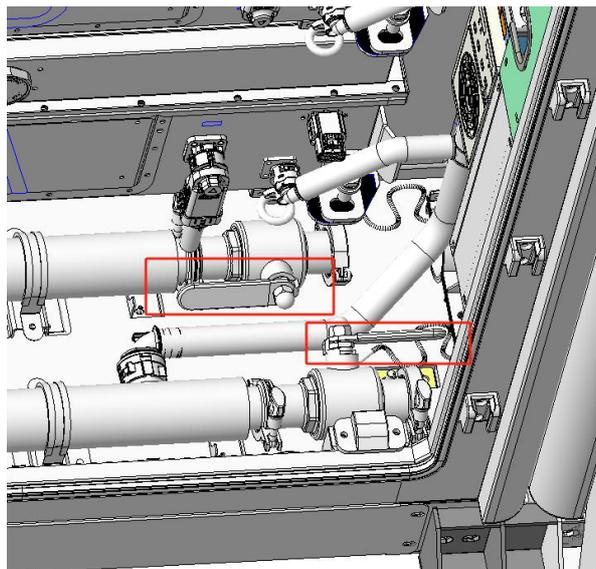

Figure 40 - Ball valve handles position

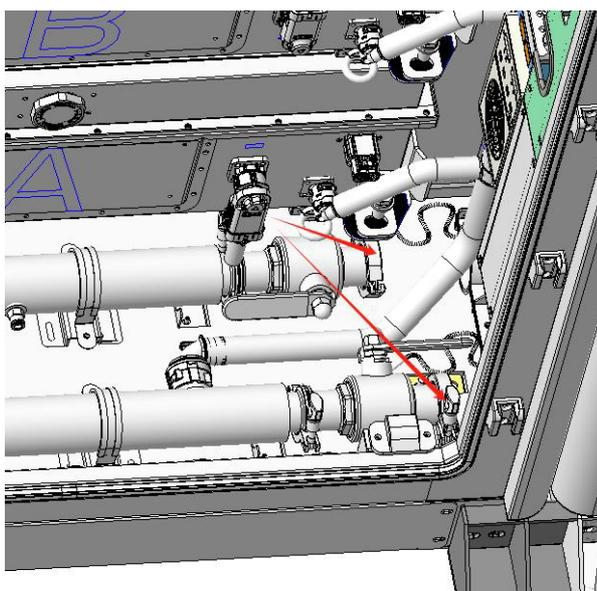

Figure 41 - Position of the first level pipe cover

Step 2

Connect the flange head of the pressure maintaining fixture to the flange head at the end of the first stage pipeline and install the sealing ring. Use a torque wrench to tighten the clamp screws at the connection, with a torque of 6-8Nm.



Figure 42 - Liquid coolant pressure maintenance tool

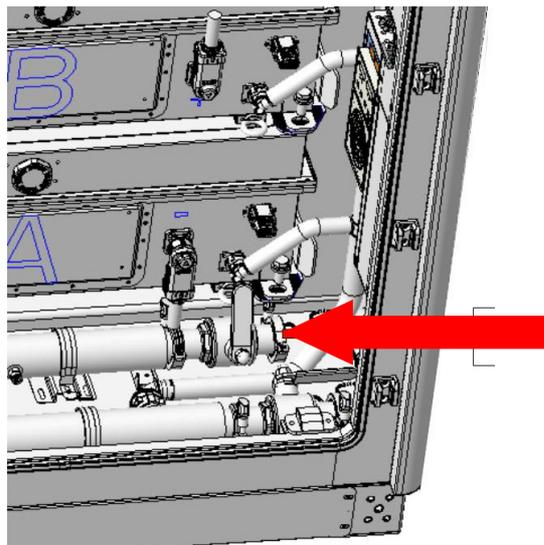

Figure 43 - Connection point of pressure maintenance tool

Step 3

Open the ball valve on the first stage pipe connected to the fixture (the handle of the ball valve is perpendicular to the direction of the pipeline). Perform pressure holding operation. If the pressure test does not meet the requirements, contact the after-sales service personnel in a timely manner. Alternatively, the pipes inside the cabinet can be reinstalled and subjected to a Tooling pressure test to troubleshoot before proceeding with the next cabinet consolidation operation

Step 4

After the pressure test is completed, insert a plastic tube with an outer diameter of 8mm into the discharge port for pressure relief. Do not proceed to the next step until the pressure relief is complete to avoid unnecessary injury. After completing the pressure relief, remove the fixture, install the removed sealing ring, clamp, and cover back in place, and tighten the clamp screw with a torque wrench to 6-8Nm. Remove the pressure relief plastic pipe and close the ball valve of the first stage pipeline.

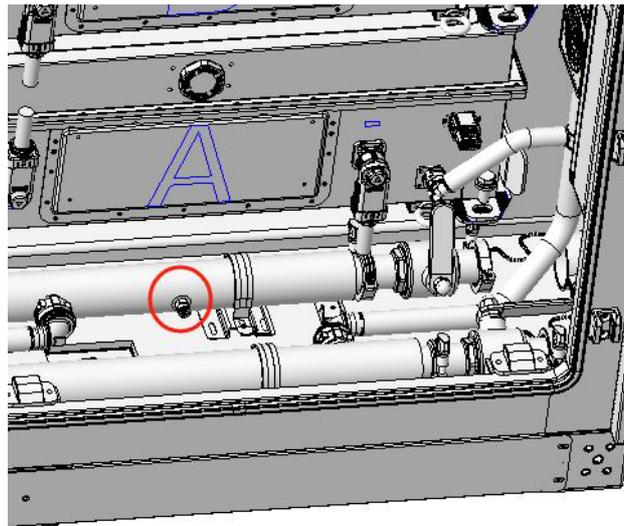

Figure 44 - Connection point of discharge pipe



Figure 45 - discharge pipe



6.1.2 Installation of liquid cooling pipelines in cabinets

The installation of liquid cooling pipelines only involves on-site installation when the energy storage main cabinet is combined with the battery cabinet or when the battery cabinet is combined with the battery cabinet. If the energy storage main cabinet is used separately, it does not involve the installation of liquid cooling pipelines for cabinet integration. The installation of the liquid cooling pipeline for the cabinet includes four steps: removing the side pipe cover plate of the cabinet, opening the sealing groove, installing the pipeline, and closing the sealing groove.

Step 1

Open the sealing slot. Open the two sealing slots between two parallel cabinets, use a screwdriver to remove four M4 screws, and rotate the sealing slots 45 degrees upwards to open them.

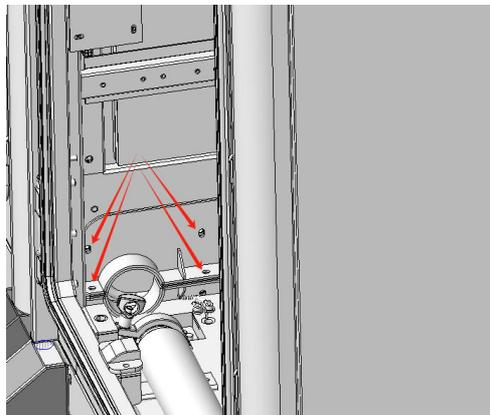

Figure 46 – screws position

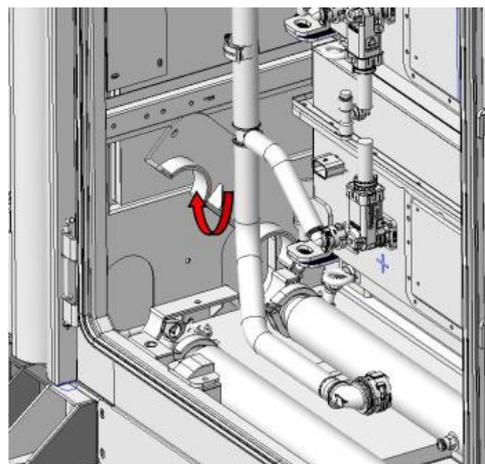

Figure 47 – slot opening

Step 2

Install the pipeline. Loosen the clamp at the end of the liquid cooling pipeline of the two parallel cabinets, and remove the covers and sealing rings inside the clamps of the two cabinets. Properly store the removed covers and sealing rings. Thread the hose through the sealing groove of the two parallel cabinets and connect the sealing ring, hose, and liquid cooling pipeline of the two cabinets with clamps. Use a torque wrench to tighten the clamp screws to a torque of 6-8Nm

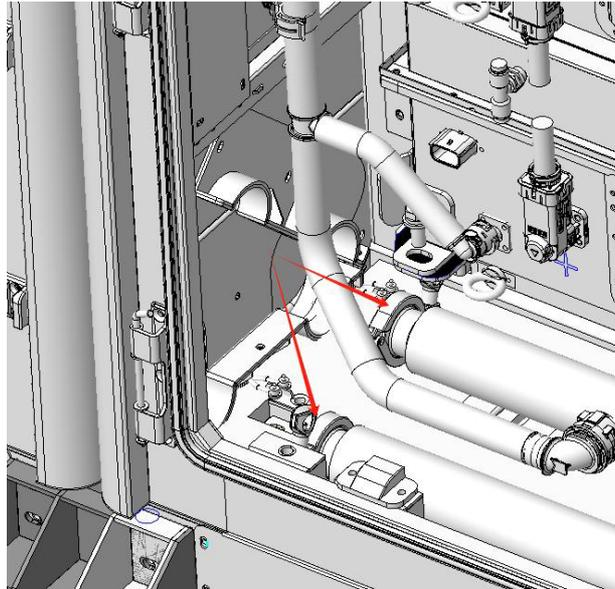

Figure 48 - clamp removal

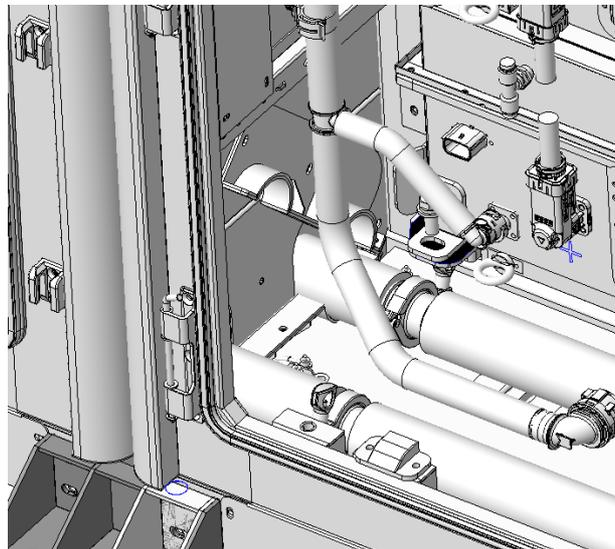

Figure 49 - hose installation and clamp lock

Attention: After locking the clamp, the clamp screw should not exceed the bottom surface of the battery pack to avoid affecting the subsequent maintenance of the battery pack.

Step 3

Close the sealing slots of two parallel cabinets. Rotate the sealing slot 45 degrees downwards to close it, and reinstall the four M4 screws with a screwdriver.

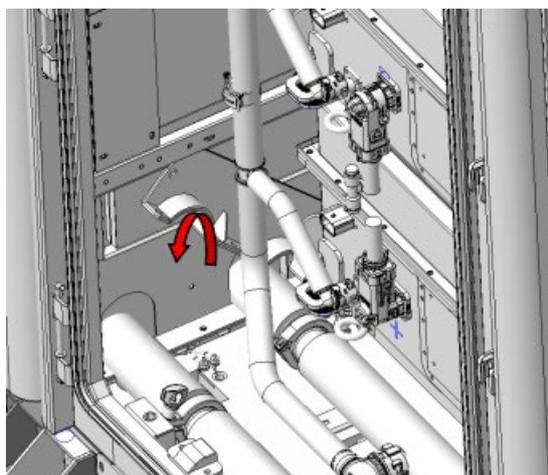

Figure 50 - flipping and closing the sealing slot

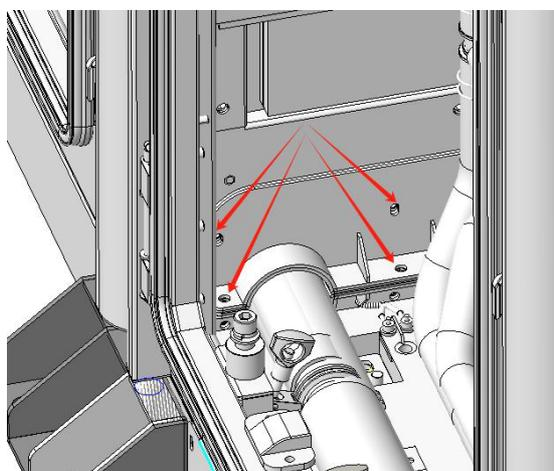

Figure 51 - screws of sealing slot

6.2 Installation of fire protection pipelines in parallel cabinets

The installation of fire protection pipelines is only installed between the energy storage cabinet and the energy storage cabinet or battery cabinet. It only involves on-site installation when sharing the same fire bottle. One energy storage cabinet can be combined with up to three battery cabinets or six energy storage cabinets simultaneously. If the energy storage cabinet is used alone, it does not involve the installation of fire protection soft circuits for cabinet integration. The installation of the liquid cooling hose for the cabinet includes four steps: opening the rotating cover plate, installing the quick connect fire pipeline, installing the pipeline clamp, and closing the rotating cover plate.

Step 1

Remove the fixing screws of the rotating cover plate on the top of the cabinet and open it by rotating it. And support the support rod well.

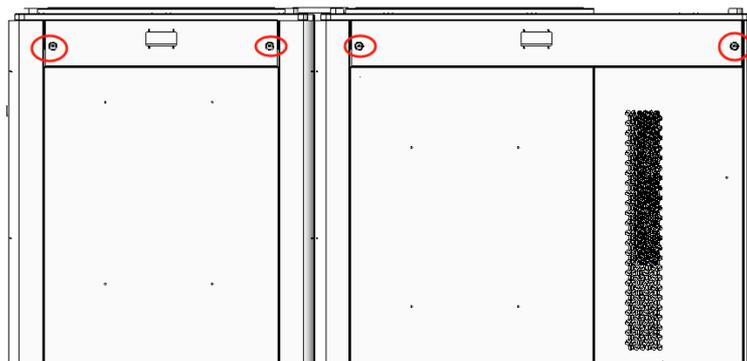

Figure 52 – screws of the cover plate

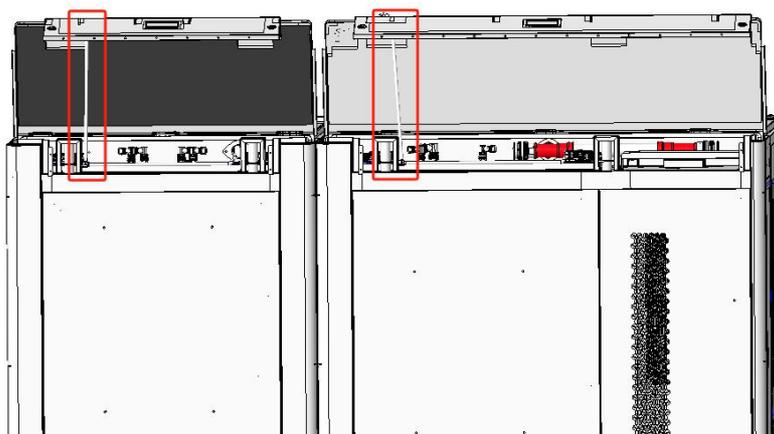

Figure 53 – top cover supported by support rod

Step 2

Install the hose of the fire protection cabinet into the quick connector of the cabinet top pipeline. During installation, pull the outer iron ring of the quick connector backwards and insert the fire protection hose into place. After installation, use your hands to pull it. If it cannot be pulled, it means it has been installed in place. Install quick plug plugs at both ends of the fire protection pipeline on the top of the cabinet. As shown in the figure

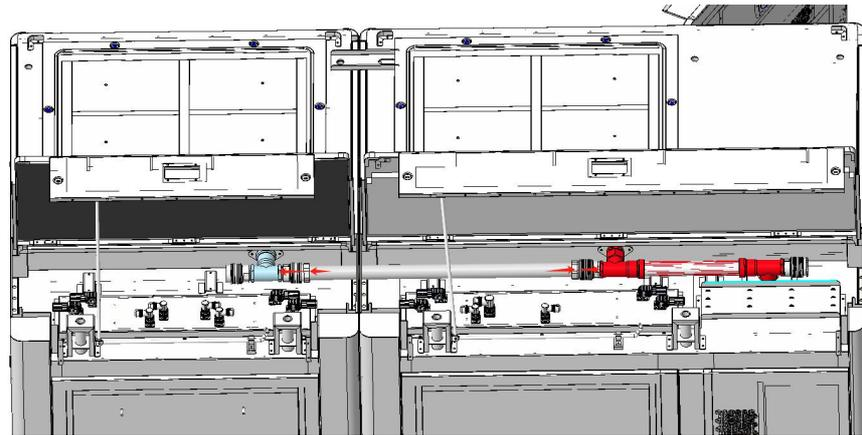

Figure 54 - fire hoses

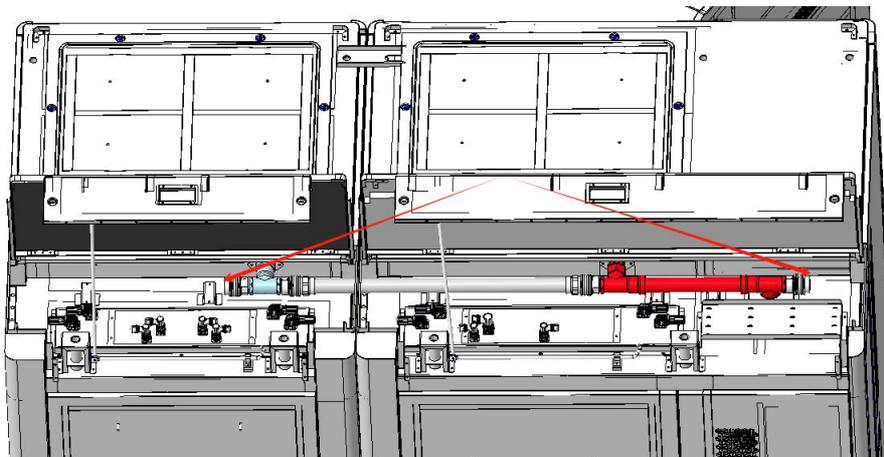

Figure 55 - quick plugs

Step 3

After the fire hose is installed in place, install the clip of the fire hose and tighten the clip with two M4 screws.

7. Power up and shut down operations

	<p>The BESS can only be put into operation after confirmation by a professional and approved by the local power department.</p> <p>For BESS with a long shutdown time, check the equipment thoroughly and carefully to ensure all indexes are acceptable before powering it on.</p>
Warning	

7.1 Indicator lights status description

Azzurro Logo status information

Type	Indicator status	Hidden meaning	Note
Green	Green Always On	Running (AC/DC relay fully closed)	
	Green flashing (1Hz)	Standby Detection	
	Green flashing (2Hz)	Upgrade	
Yellow	Yellow always on	First level alert	
	Yellow flashing (2Hz)	Secondary alarm	
Red	Red Always On	Trip alarm	
	Red flashing (2Hz) + Buzzer	FFS alarm	(fire-activated faults, not faults in the FFS itself)
Go out	Go out	Turn off	

PCS indicator status information

Type	Indicator status	Hidden meaning	Note
POWER	Green light always on	DC side charged	
	Red light always on	DC side fault	Leakage current, DC side reverse connection, bus over-undervoltage
	Red light flashing	master-slave disconnect	
RUN	Green light always on	normal operation	

	Green light flashes	Non-grid-connected but trouble-free operation	1s on,1s off
	Red light always on	Grid-side faults	Abnormalities in grid phase, frequency, amplitude; phase loss, unbalance
ALARM	Red light always on	Device Alarms	DC-side faults, grid-side faults, and alarms generated by the PCS itself
	Red light flashing	communication alarm	1s on,1s off
	Go out	No alarm	

High voltage box indicator status information

Type	Indicator status	Hidden meaning	Note
Green	Green light always on	Main contactor closed, manual switch QB2 disconnected	
	Slow flash 1Hz	BMS system powered, main contactor not closed	
	Flash 2Hz	The BMS system is powered, the main contactor is closed, the manual switch QB2 is closed, and the prompt can disconnect the manual switch QB2	
Red	Red light always on	System malfunction shutdown, relays are disconnected	
Go out		No auxiliary power on the DC side of the system	

7.2 Power on operations

The prerequisite for this part of the operation is that the storage cabinet is in a normal un-started state, specifically all switches of the high voltage box, auxiliary power module, and system convergence module are in the off state, the positive and negative buses of the battery clusters have not yet been connected to the battery PACKs (this step is for the first time when the power is turned on), and the three-phase AC input power cables are connected and have a normal voltage input.

7.2.1 Check before powering on

Before powering up the equipment, check the following items carefully.

- Check whether the wiring is correct.
- Check whether the protective covers inside the equipment are installed firmly.
- Check whether the emergency stop button is released.
- Check and ensure that there is no grounding fault.
- Check whether the AC and DC voltages meet startup conditions and ensure that there is

no over-voltage with a multimeter.

- Check and ensure that no tools or components are left inside the equipment.
- Check all air inlets and outlets are free of foreign objects that may be obscuring or blocking them.
- Check whether the cabinet door is closed

7.2.2 Steps for powering on under normal conditions

After making sure that the energy storage system is in a normal un-started state, the power-on operator needs to take insulation protection measures.

After making sure that all the power cables between PACKs are connected correctly in the storage cabinet and the battery cabinet, the operator need to wear insulated gloves and insert the positive and negative power wire plugs into the battery cluster corresponding terminals (the other ends have already been connected to the high-voltage box B+ and B- terminals in the factory) and then make sure the plugs are fully inserted into place.



Figure 56 – Battery cluster positive and negative plugs locations

Use a multimeter to measure whether there is AC220V AC power at the main input of the auxiliary power box in the energy storage cabinet, If yes, then close the QA1 total power switch, use a multimeter to measure the output voltage of QA1 is normal. Then close QA2 to power the liquid-cooling machine. Then close QA3 to power the CMU module, the fire fighting system, dehumidifier, flood sensor switch, lighting and other equipment. Then close QA4 to power the BCU and indicator light (the green light will be flashing with the 1Hz frequency) in the high-voltage box, the BMUs in the PACKs.



Figure 57 – Auxiliary modules switches

Note that this QA5 switch is only configured in a single energy storage cabinet scenario for CSU power supply. In other scenarios, QA5 is not configured. Before closing the switch, you need to use a multimeter to measure whether the voltage of QA5 is DC 24V , if the input voltage is 24V, then close QA5 to power CSU. After this, all auxiliary power supply of energy storage system is completed. The socket and leakage protection switch RCB01 on the auxiliary power box of the energy storage cabinet can be used according to the customer needs.

Put the isolation switch QB of high-voltage boxes in the energy storage cabinet or the battery cabinet in the "ON" position.



Figure 58 – Battery disconnection switch QB in High voltage box

Manually close the QA1 main power switch and the QA6 lightning protection switch in the auxiliary power module. The green light on the front door of the auxiliary power module should be illuminated after closing the QA1 main power switch. Using a multimeter to measure the circuit breaker QA0 input is normal three-phase AC400V,if yes then close the QA0, and then the PCS indicator is bright and the ZCS LOGO light in the door is green. Please refer to the Table 6.2 to check the PCS status.

At this point, the power-on operation of the energy storage system is completed, and then the subsequent control logic will be collaborated by CSU, CMU, BCU, BMU, fire protection system, liquid cooling unit and other modules.

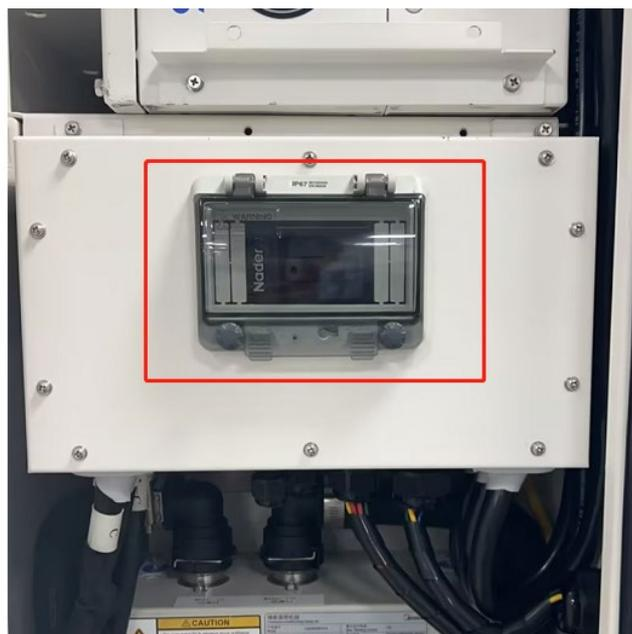

Figure 59 – PCA AC side switch QA0 of energy storage cabinet

7.3 Shut down under normal conditions

During power-down operation, the PCS AC side module case circuit breaker QA0, the battery disconnect switch QB in the high voltage box, and the battery cluster positive and negative bus plugs should be avoided to be switched on and off or plugged in with load. Insulation protection measures are required for the personnel performing the power-down operation.

The procedure for normal power-down operation is as follows:

1) It is necessary to carry out the power-down operation on the WEB interface first. After the power down command is issued, if there is a PCS connected, the PCS should stop charging and discharging first, and then the battery cluster will automatically carry out the power down operation, and at the same time, the two positive and negative main relays (KF1 and KF2) and auxiliary relay (KF4) inside the corresponding high-voltage box should be able to be disconnected.

2) Manually disconnect all high-voltage box battery disconnect switches QB in the energy storage cabinet and battery cabinets.

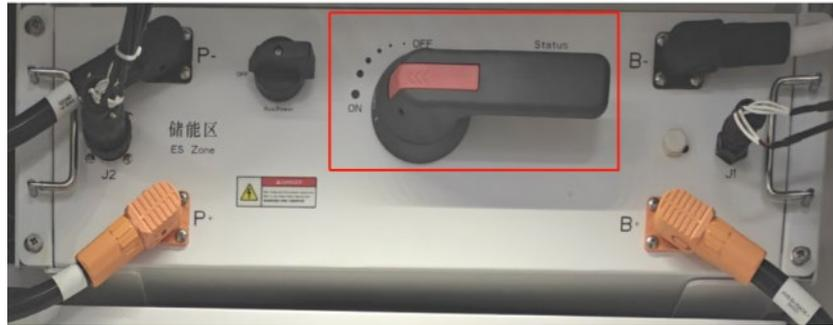

Figure 60 – Battery disconnection switch QB in High voltage box

3) With insulated gloves, unplug the positive and negative power bus plugs from the Pack to the high voltage box in the battery cluster of the energy storage cabinet and battery cabinets.



Figure 61 – Battery cluster positive and negative plugs locations

4) Manually switch off the PCS AC side module case circuit breaker QA0 in the distribution compartment of the energy storage cabinet.

5) Manually switch off the three-phase AC main circuit breaker outside the energy storage cabinet, so that the main circuit of the energy storage system is powered down.

6) Auxiliary power part of the power down

7) Disconnect the QA5 circuit breaker in the auxiliary power box;

- 8) Disconnect the QA4 circuit breaker in the auxiliary power box, then all the BCUs in the high-voltage box, all the BMUs in the battery PACK are powered down;
- 9) Disconnect the QA3 circuit breaker, then the CMU module, fire fighting system, dehumidifier, flooding switches, lighting and other equipment is powered down;
- 10) Disconnect the QA2 Circuit breaker, then the cabinet liquid cooling unit power down;
- 11) Disconnect the socket and RCD01 leakage protection switch (if there is a closed switch is disconnected);
- 12) Disconnect the auxiliary power box total input switch QA1.



Figure 62 - Auxiliary modules switches

- 13) Disconnect the auxiliary power box single-phase AC circuit breaker outside the energy storage cabinet, so that the auxiliary power down operation of the energy storage system is completed.

7.4 Shut down under emergency conditions

The premise of this step is that the energy storage system is powered up and running in the process of emergencies that require emergency power down, such as smoke, fire, electric shock and so on.

The procedure for powering down in an emergency is as follows:

- 1) In case of emergency, press the emergency stop button on the front door of the storage cabinet. When the emergency stop button is pressed, the PCS should stop charging and discharging the batteries, and all the positive and negative main relays (KF1/KF2) inside the high voltage box and the auxiliary relay (KF4) inside the high voltage box should be disconnected immediately.



Figure 63 – Emergency stop button switch

2) Disconnect the battery disconnect switch QB of all high voltage boxes in the energy storage cabinet and battery cabinets.

3) Disconnect circuit breaker QA0 on the three-phase AC side of the PCS inside the storage cabinet, and continue to disconnect the AC input circuit breaker outside the storage cabinet, if necessary.

4) Disconnect the QA1 main power switch in the auxiliary power box, the emergency power down operation can be ended at this step, if necessary, you can continue to disconnect the external single-phase AC power switch outside the auxiliary power box

8. Maintenance and warranty

	<p>Please do not open the door of the battery box for maintenance in rainy, wet or windy weather, if you fail to avoid it, we will not be responsible for any damage caused.</p>
<p>Warning</p>	<p>Avoid opening the door in rain, snow or foggy weather when humidity is high, and make sure that the seal around the door does not curl when the door is closed.</p> <p>To reduce the risk of electric shock, do not perform any maintenance or overhaul operations other than those described in this manual. If necessary, contact our customer service personnel for maintenance and overhaul.</p>

Maintenance is mandatory in order to maintain the warranty of the product, please refer to the attached maintenance document in order to follow the correct maintenance plan

Please refer to warranty terms and condition on www.zcsazzurro.com



THE INVERTER THAT LOOKS AT THE FUTURE

zcsazzurro.com



Zucchetti Centro Sistemi S.p.A.
Green Innovation Division
Palazzo dell'Innovazione - Via Lungarno, 167
52028 Terranuova Bracciolini - Arezzo, Italy
zcscompany.com

