



# USER'S MANUAL



---

## THREE-PHASE STRING INVERTERS

3PH 250-350KTL HV-ZO

---



**ZUCCHETTI**  
Centro Sistemi



## IMPORTANT COMMUNICATION

Inside the box of this product is available the manual in English. Please note that more up-to-date revisions of the supplied manual may be available. Therefore, in order to ensure the correct installation and maintenance procedure it is necessary to verify the manuals, available in all languages, within the documentation or products section of the [www.zcsazzurro.com](http://www.zcsazzurro.com) website, the same documentation is also available by scanning the qr code on the front of the product or directly within the app Azzurro Operators.

Datasheets, technical notes, certifications and warranty terms and conditions are also available on the above platforms.

# Grid-connected inverter 3PH 250KTL-350KTL HV-Z0 User Manual





# Table of Contents

1.	Preliminary safety instructions .....	8
1.1.	Safety instructions .....	8
1.2.	Symbols and icons.....	11
2.	Product features.....	13
2.1.	Product presentation.....	13
2.2.	Description of functions .....	16
2.3.	DC Switch Descriptions.....	17
3.	Inverter Storage.....	18
4.	Installation.....	19
4.1.	Installation process .....	20
4.2.	Checks before installation.....	20
4.3.	Installation tools .....	22
4.4.	Installation position .....	24
4.5.	Moving the 3PH 250KTL-350KTL HV-Z0 inverter.....	27
4.6.	Installing the 3PH 250KTL-350KTL HV-Z0 inverter .....	30
5.	Electrical connections.....	33
5.1.	Electrical connections .....	34
5.2.	Terminal connector .....	34
5.3.	Connecting PNGD cables (grounding).....	36
5.4.	Connecting the AC output power cables.....	38
5.5.	Connecting the DC input power cables .....	43
5.6.	Recommended Wiring Methods.....	46
5.7.	Connecting the communication cables .....	47
6.	Commissioning the inverter .....	54
6.1.	Safety inspection before commissioning.....	54
6.2.	Starting the inverter .....	55
7.	APP Azzurro Operators .....	59
7.1.	Overview .....	59



7.2.	Download.....	59
7.3.	Account Registration and Login.....	60
7.3.1.	Registration.....	60
7.4.	Local Control .....	61
7.4.1.	Bluetooth Connection.....	61
7.4.2.	Dashboard .....	63
7.4.3.	Info.....	64
7.4.4.	Setting .....	65
8.	Operating interface .....	66
8.1.	Operating panel and display .....	66
8.2.	Updating Inverter Software .....	67
8.3.	Safety Regulation Management.....	68
9.	Troubleshooting and maintenance .....	69
9.1.	Troubleshooting.....	69
9.2.	Maintenance .....	75
9.3.	Maintenance .....	76
9.4.	SVG.....	76
10.	Uninstalling.....	77
10.1.	Uninstallation steps.....	77
10.2.	Packaging.....	77
10.3.	Storage .....	77
10.4.	Disposal .....	77
11.	Technical data 3PH 250-350KTL HV-Z0.....	78
12.	Monitoring systems.....	79
12.1.	External Wi-Fi adapter.....	79
12.1.1.	Installation.....	79
12.1.2.	Configuration.....	81
12.1.3.	Verification .....	89
12.1.4.	Troubleshooting.....	91
12.2.	Ethernet adapter.....	95
12.2.1.	Installation.....	95

12.2.2.	Verification .....	97
12.2.3.	Troubleshooting.....	98
12.3.	4G adapter .....	100
12.3.1.	Installation.....	100
12.3.2.	Verification .....	102
12.4.	Datalogger .....	105
12.4.1.	Preliminary notes on how to configure the datalogger.....	105
12.4.2.	Electrical connections and configuration.....	106
12.4.3.	ZSM-DATALOG-04 AND ZSM-DATALOG-10 DEVICES.....	111
12.4.4.	WI-FI CONFIGURATION .....	111
12.4.5.	Ethernet configuration.....	111
12.4.6.	Checking that the datalogger has been configured correctly.....	118
12.4.7.	ZSM-RMS001/M200 and ZSM-RMS001/M1000 Devices.....	122
12.4.7.1.	Mechanical description and Datalogger interface.....	122
12.4.7.2.	Connecting the Datalogger to the inverters.....	123
12.4.7.3.	Internet connection via Ethernet cable.....	123
12.4.7.4.	Connecting the power supply and battery pack to the Datalogger .....	123
12.4.7.5.	Connecting the LM2-485 PRO cell irradiance and temperature sensor to the datalogger .....	124
12.4.8.	Configuring the Datalogger .....	125
12.4.8.1.	Configuring the Datalogger on the ZCS Azzurro portal.....	127
12.4.8.2.	Network configuration.....	128
12.4.9.	Local monitoring.....	130
12.4.9.1.	Requirements for installation of local monitoring.....	130
12.4.9.2.	Features of local monitoring.....	130
13.	Warranty terms and conditions.....	131

## General instructions

This manual contains important safety instructions that must be followed during installation and maintenance of the equipment.

### **Please keep these instructions!**

This manual must be considered an integral part of the equipment, and must be available at all times to everyone who interacts with the equipment. The manual must always accompany the equipment, even when it is transferred to another user or plant.

## Copyright statement

Copyright of this manual belongs to Zucchetti Centro Sistemi S.p.A. No part of this manual (including the software, etc.) may be copied, reproduced or distributed in any form or by any means without the permission of Zucchetti Centro Sistemi S.p.A. All rights reserved. ZCS reserves the right to final interpretation. This manual is subject to change based on feedback from users, installers or customers. Please check our website <http://www.zcsazzurro.com> for the latest version.

## Technical support

ZCS offers a support and technical consultancy service accessible by sending a request directly from the website [www.zcsazzurro.com](http://www.zcsazzurro.com)

For the Italian territory, the following toll-free number is available: 800 72 74 64.



## Preface

### General information

Please read this manual carefully before installation, use or maintenance.

This manual contains important safety instructions that must be followed during installation and maintenance of the system.

- **Scope**

This manual describes the assembly, installation, electrical connections, commissioning, maintenance and troubleshooting of the following inverters:

**3PH 250KTL-HV-Z0 / 3PH 330KTL-HV- Z0 / 3PH 350KTL-HV- Z0**






Keep this manual so that it is accessible at all times.

- **Recipients**

This manual is intended for qualified technical personnel (installers, technicians, electricians, technical support personnel or anyone who is qualified and certified to operate a photovoltaic system), who are responsible for installing and starting the inverter in the photovoltaic system and for operators of the photovoltaic system.

- **Symbols used**

This manual provides information for safe operation and uses certain symbols to ensure the safety of personnel and materials, and for efficient use of the equipment during normal operation. It is important to understand this information to avoid accidents and damage to property. Please take note of the following symbols used in this manual.

	<b>Danger:</b> indicates a hazardous situation which, if not resolved or avoided, could result in serious personal injury or death.
<b>Danger</b>	
	<b>Warning:</b> indicates a hazardous situation which, if not resolved or avoided, could result in serious personal injury or death.
<b>Warning</b>	
	<b>Caution:</b> indicates a hazardous situation which, if not resolved or avoided, could result in minor or moderate personal injury.
<b>Caution</b>	
	<b>Attention:</b> indicates a potentially hazardous situation which, if not resolved or avoided, could result in damage to the system or other property.
<b>Attention</b>	
	<b>Note:</b> provides important tips on the correct and optimal operation of the product.

## 1. Preliminary safety instructions



Note

If you have problems or questions regarding the reading and understanding of the following information, please contact Zucchetti Centro Sistemi S.p.A. through the appropriate channels.

### General information in this chapter

#### Safety instructions

It mainly highlights the safety instructions to be followed during installation and use of the equipment.

#### Symbols and icons

Introduces the main safety symbols on the inverter.

### 1.1. Safety instructions

Before installing and using the equipment, make sure you read and understand the instructions in this manual and familiarise yourself with the relative safety symbols shown in this chapter.

Depending on national and local requirements, permission must be obtained from your local provider before connecting to the electrical grid, making sure that the connections are carried out by a qualified electrician.

Contact the nearest authorised service centre for any repairs or maintenance. Contact your distributor for information on the nearest authorised service centre. **DO NOT** carry out repairs yourself, as this may result in injury or damage.

Before installing and operating the equipment, the electrical circuit of the strings must be disconnected by opening the string circuit breaker to interrupt the high-voltage DC of the photovoltaic system. Failure to do so could result in serious injury.

#### Qualified personnel

Ensure that the operator has the necessary skills and training to operate the equipment. Personnel responsible for use and maintenance of the equipment must be qualified and capable of performing the activities described, and must also have appropriate knowledge on how to correctly interpret the contents of this manual. For safety reasons, this inverter can only be installed by a qualified electrician with the necessary training and/or skills and knowledge. Zucchetti Centro Sistemi S.p.A. declines all responsibility for damage to property or personal injury caused by incorrect use of the device.

#### Label and Symbols

ZCS AZZURRO 250/350KTL HV-Z0 has type label attach the side of product which contact important information and technical data, the type label must permanent attached to the product.

ZCS AZZURRO 2250/350KTL HV-Z0 has warning symbol attach the product which contact information of safety operation. The warning symbol must permanent attached to the product.

#### Installation requirements

Please install the inverter according to the following section. Place inverter in an appropriate bearing capacity object (such as solid brick wall, or strength equivalent mounting surface, etc.) and make sure inverter vertical placed. A proper installation location must have enough space for fire engine access for maintenance if faulty occur. Ensure the inverter is installed in a wall ventilated environment and have enough air cooling cycle. Air humidity should less than 90%.

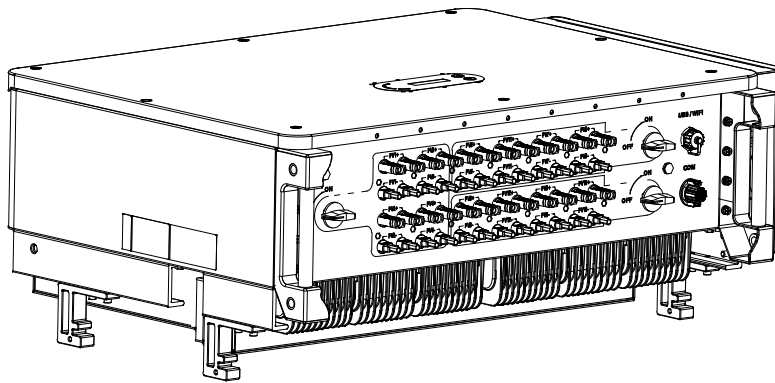






Figure 1 - Do not lose or damage this manual

### Transport requirements

If you encounter problems with the packaging, or if you find any visible damage, please notify the transport company immediately. If necessary, request assistance from an installer of photovoltaic systems or from Zucchetti Centro Sistemi S.p.A. Transport of the equipment, especially by road, must be carried out with vehicles suitable to protect the components (in particular, electronic components) against violent knocks, humidity, vibrations, etc.



### Electrical connections

Please pay attention to the electrical regulations on accident prevention when dealing with photovoltaic inverters.



	<b>Before connecting the mains power, be sure to disconnect the photovoltaic modules by disconnecting all the DC switches of the generator. When exposed to the sun, the photovoltaic panels produce a voltage that can be dangerous!</b>
<b>Danger</b>	
	<b>All installation operations must be carried out by a professional electrician, who must:</b>
<b>Warning</b>	<ul style="list-style-type: none"> <li>• Be prepared.</li> <li>• Carefully read this manual and understand its contents.</li> </ul>
	<b>Before connecting the inverter to the grid, make sure that all the necessary permits have been obtained from the local grid operator and that all the electrical connections are made by a professional electrician.</b>
<b>Attention</b>	
	<b>Do not remove the information label or open the inverter. Otherwise, ZCS will not provide any warranty or maintenance.</b>
<b>Note</b>	



## Operation

	<p>Contact with the electrical grid or the terminal of the equipment may cause electrocution or fire!</p> <ul style="list-style-type: none"> <li>• Do not touch the terminal or the conductor connected to the electrical grid.</li> <li>• Follow all the instructions and safety requirements relating to the mains connection.</li> </ul>
<b>Danger</b>	
	<p>Some internal components reach very high temperatures when the inverter is in operation. Wear protective gloves!</p>
<b>Attention</b>	


## Maintenance and repair

	<ul style="list-style-type: none"> <li>• Before carrying out any repairs, disconnect the inverter from the mains network (AC side) and from the photovoltaic system (DC side).</li> <li>• After switching off the AC and DC switches, wait 5 minutes before carrying out any repairs or maintenance on the inverter!</li> </ul>
<b>Danger</b>	
	<ul style="list-style-type: none"> <li>• The inverter should start working again after any faults have been fixed. For any repairs, contact your local authorised service centre;</li> <li>• Do not disassemble the internal components of the inverter without permission. This will void the warranty. Zucchetti Centro Sistemi S.p.A. shall not be responsible for any damage or loss caused by these actions.</li> </ul>
<b>Attention</b>	

## EMC/Noise Level





Electromagnetic compatibility (EMC) refers to that on electrical equipment functions in a given electromagnetic environment without any trouble or error, and impose no unacceptable effect upon the environment. Therefore, EMC represents the quality characters of an electrical equipment.

- The inherent noise-immune character: immunity to internal electrical noise
- External noise immunity: immunity to electromagnetic noise of external system
- Noise emission level: influence of electromagnetic emission upon environment

	<p><b>Electromagnetic radiation from inverter may be harmful to health!</b> Please do not continue to stay away from the inverter in less than 20cm when inverter is working</p>
<b>Danger</b>	





## 1.2. Symbols and icons




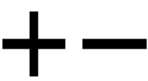


### Safety signals

	<p><b>High voltage of inverter may be harmful to health! Only qualified personnel can operate the product.</b>  <b>Keep this product out of the reach of children.</b></p>
<b>Danger</b>	
	<p><b>Pay attention to possible burns due to hot parts.</b>  <b>Only touch the screen or press the keys while the inverter is in operation.</b></p>
<b>Caution</b>	
	<p><b>The PV strings should be connected to the ground in accordance with the local regulations!</b>  <b>To ensure the safety of the system and people, the inverter and photovoltaic strings must be securely connected to the ground.</b></p>
<b>Attention</b>	
	<p><b>Ensure the correct DC input voltage; which must be below the maximum allowable DC voltage. Overvoltage can cause permanent damage to the inverter or other faults which are not covered by the warranty!</b></p>
<b>Warning</b>	

### Symbols on the inverter

Some safety symbols are located on the inverter. Read and understand the contents of the symbols before installing the inverter.

	<p><b>Residual voltage may be present on the inverter!</b>          After disconnect with the DC side, there is a residual voltage in the inverter, operator should wait for 25 minutes to ensure the capacitor is completely discharged.</p>
	<p><b>Beware of high voltage!</b>          The products operates at high voltages. Prior to performing any work on the product, disconnect the product from voltage sources. All work on the product must be carried out by qualified persons only.</p>
	<p><b>Beware of high temperatures!</b>          The product can get hot during operation. Avoid contact during operation. Prior to performing any work on the product, allow the product to cool down sufficiently.</p>
	<p>Complies with the European Standards (CE)</p>

	<p>Ground connection point. This symbol indicates the position for the connections of an additional equipment grounding conductor.</p>
	<p>Read this manual before installing the inverter.</p>
	<p>Indication of the allowable temperature range</p>
	<p>Positive and negative polarities of the input voltage (DC).</p>
	<p>RCM (Regulatory Compliance Mark). The product complies with the requirements of the applicable Australian standards.</p>
	<p>WEEE designation. Do not dispose of the equipment with household garbage at its end of life. Dispose of it according to local laws and regulations or send it to the manufacturer.</p>



## 2. Product features

### General information in this chapter

#### Product overview

The field of use and overall dimensions of the 3PH 250/350KTL HV-Z0 inverters are indicated in this section.

#### Description of functions

It describes how the 3PH 250/350KTL HV-Z0 inverters and their internal operating modules work.

#### Efficiency curve

Describes the efficiency curves of the inverter.

### 2.1. Product presentation

#### Field of use

The 3PH 250KTL-350KTL inverters are grid-connected photovoltaic inverters equipped with 6-8 MPPT, capable of converting the direct current generated by the photovoltaic strings into three-phase sine wave alternating current and feeding the energy to the public electricity grid. An AC circuit breaker must be used as a disconnecting device and must always be easily accessible.

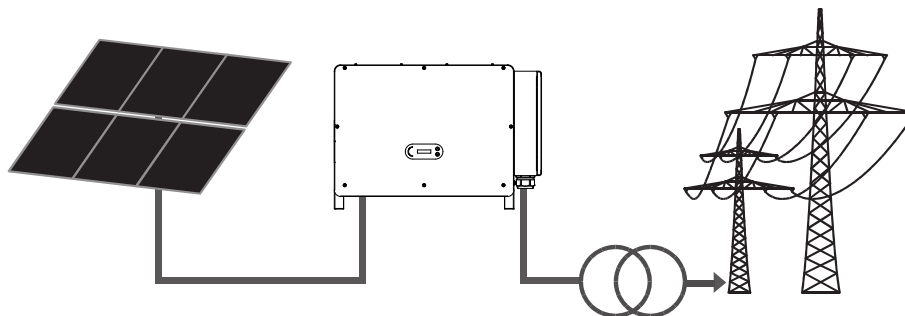
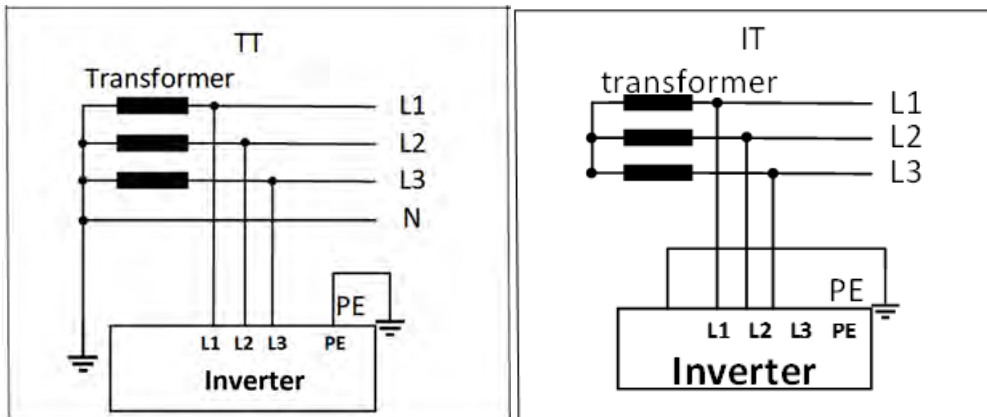


Figure 2 – Grid-connected photovoltaic system

3PH 250/350KTL HV-Z0 series is a transformerless on grid PV Inverter.

The 3PH 250/350KTL HV-Z0 may only be operated with PV arrays (photovoltaic module and cabling) for on grid condition. Do not use this product for any other or additional purposes. Any damage or property loss due to any use of the product other than described in this section, Zucchetti Centro Sistemi will not take the responsibility. DC input of the product must be PV module, other source such like DC sources, batteries will against the warranty condition and ZCS will not take the responsibility.

### Supported grid type



### Dimensions description

- Overall dimensions: L x W x H = 1159 mm x 366 mm x 828 mm

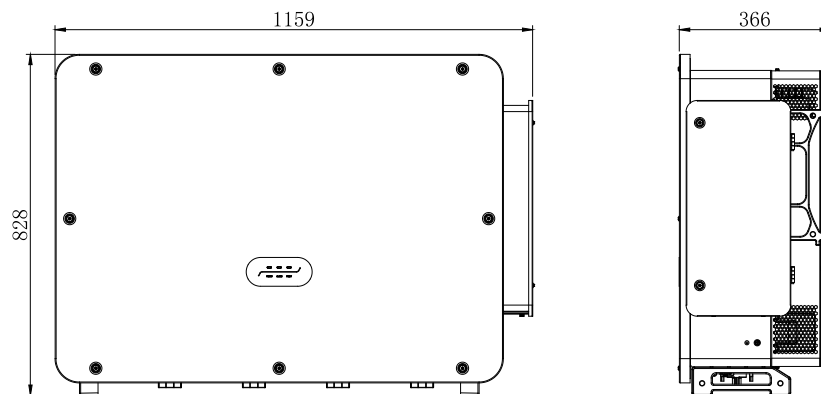
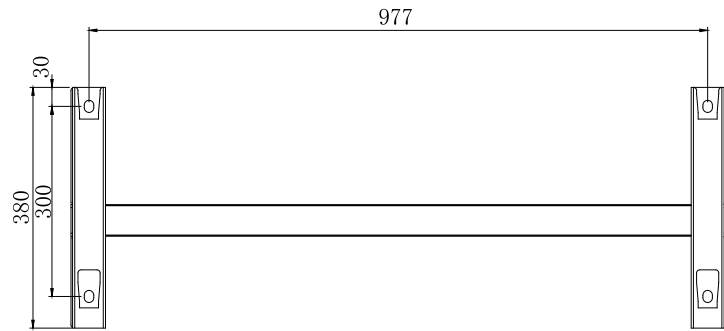
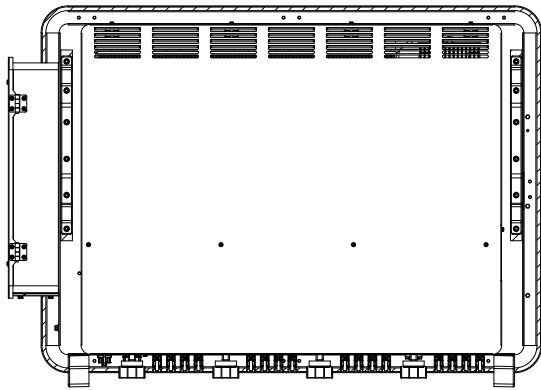


Figure 3 – Front, side and back view of the inverter and bracket



- Labels on the inverter

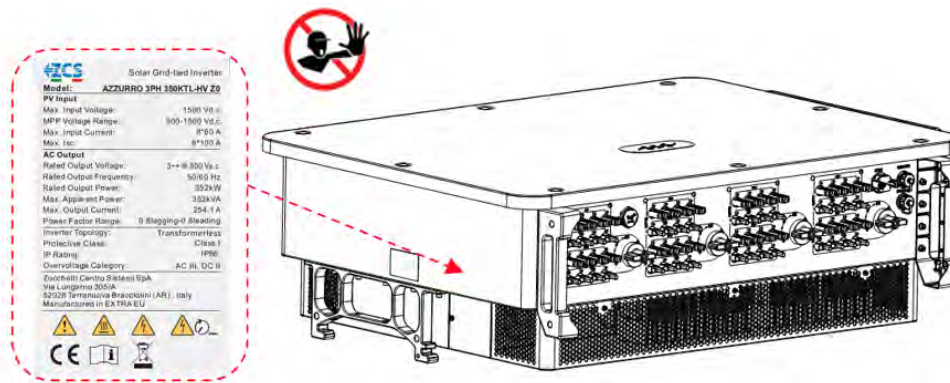


Figure 4 – Do not remove the label on the side of the inverter

## 2.2. Description of functions

DC power generated by PV arrays is filtered through Input Board then enter Power Board. Input Board also offer functions such as insulation impedance detection and input DC voltage/ current detection. DC power is converted to AC power by Power Board. AC power is filtered through Output Board then AC power is fed into the grid. Output Board also offer functions such as grid voltage/ output current detection, GFCI and output isolation relay. Control Board provides the auxiliary power, controls the operation state of inverter and shows the operation status by Display Board. Display Board displays fault code when inverter is abnormal operation conditions. At the same time, Control Board can trigger the replay to protect the internal components.

### Electrical block diagram

AZZURRO 3PH 250/350KTL HV-Z0 has 24-32 DC input strings. 6-8 MPPT trackers that converts the direct current of PV array to grid-compliant, three phase current and feeds in into the utility grid. Both DC and AC side has Surge Protection Device (SPD).

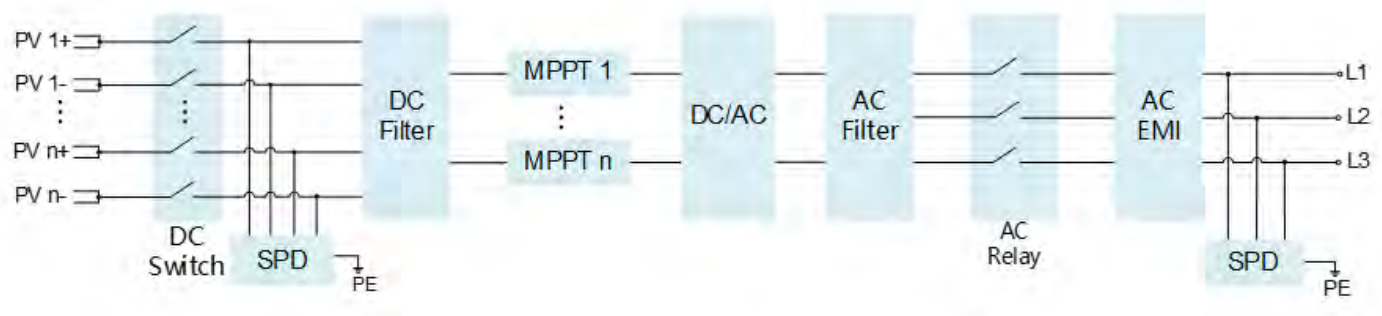


Figure 5 - Block diagram of the 3PH 250KTL-350KTL inverters

### Inverter functions

#### A. Energy management unit

Remote control to start/ shunt down inverter through an external control.

#### B. Feeding reactive power into the grid

The inverter is able to produce reactive power thus to feed it into the grid through the setting of the phase shift factor. Feed-in management can be controlled directly by the grid company through a RS485 interface.

#### C. Limited the active power fed into the grid

If enable the limited of active power function, inverter can limit the amount of active power fed into the grid to the desired value (expressed as percentage).

#### D. Self-power reduction when grid is over frequency

When the grid frequency exceeds the limit set, the inverter reduces the power in order to ensure the stability of the grid.

#### E. Data transmission

The inverter (or a group of inverters) can be monitored remotely via an advanced communication system based on RS485 interface, via external data loggers, via Wi-Fi, GPRS or Ethernet.

#### F. Software update



USB interface for uploading the firmware, remotely uploading is available.

### G. PID (optional function)

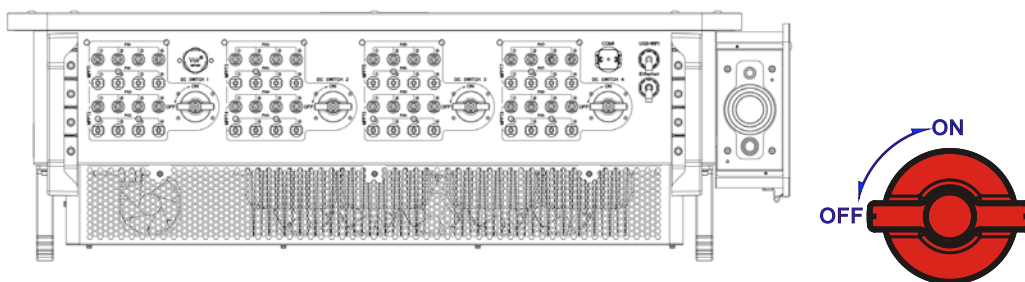
The PID effect can be recovered at night to protect the PV modules.

### H. H. AFCI (optional function)

When the DC connector is not assembled in place, it is easy to cause arcing or overheating of the connector. This function can detect whether there is a fault arc at the input end of the inverter. When an arc occurs, the inverter stops grid connection and gives an alarm reminder, to build a safe barrier for the whole system.

## 2.3. DC Switch Descriptions

The inverter is equipped with four DC switches, and per DC switch controls two MPPTs which can safely disconnect it from PV strings. Each switch controls the DC terminals in the area where the switch is located.



### DESCRIPTIONS:

SWITCH	DESCRIPTIONS	
DC SWITCH	"ON"	The DC switch is closed and has breaking protection.
	"OFF"	The DC switch is disconnected.

**DC SWITCH** automatically breaks and disconnects when a fault occurs.

Please check the type of fault through the "AZURRO OPERATOR" APP first, wait at least 3min after troubleshooting, and operate under the guidance of the technical support staff.

### DC SWITCH BREAKING :

**DC SWITCH** carries out automatic breaking and de-coupling in the event of inverter malpractices such as PV string reversal, string overcurrent, and string current backfeeding.

**DC SWITCH** also automatically breaks and disconnects when the inverter has an internal fault. The FAULT indicator light is always on, and all four DC switches are automatically disconnected. Please contact the company's technical support staff after the switches are disconnected, and do not close the DC switches by yourself.



### 3. Inverter Storage

If inverter is not installing immediately, storage condition need meet below requirements:

- ✓ Place inverter into the original package and leave desiccant inside, sealed tight with taps.
- ✓ Keep the storage temperature around  $-40^{\circ}\text{C} \sim 70^{\circ}\text{C}$ , Relative humidity  $0 \sim 95\%$ , no condensation.

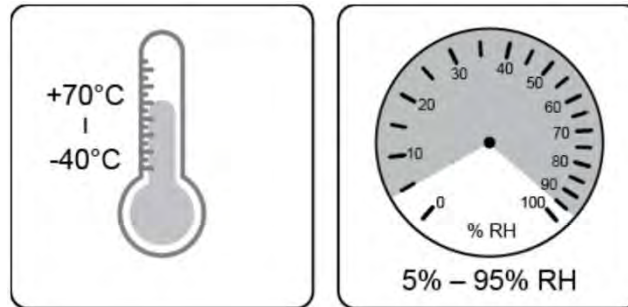


Figure 6 - Storage temperature and humidity




- ✓ The maximum stacking layer number cannot exceed 4 layers.
- ✓ If the inverter be storage for more than half years, the inverter needs to be fully examined and tested by qualified service or technical personnel before using.

## 4. Installation

### General information in this chapter

This chapter describes how to install the 3PH 250/350KTL HV-Z0 inverter.

### Installation notes:

	<ul style="list-style-type: none"> <li>• <b>DO NOT</b> install 3PH 250/350KTL HV-Z0 inverters near flammable materials.</li> <li>• <b>DO NOT</b> install 3PH 250/350KTL HV-Z0 inverters in an area where flammable or explosive materials are stored.</li> </ul>
<b>Danger</b>	
	<p>The enclosure and heat sink will get hot during operation, please do not mount the product at a easy to reach location.</p>
<b>Warning</b>	
	<ul style="list-style-type: none"> <li>• Consider the weight of the inverter when handling and transporting the inverter.</li> <li>• Choose an appropriate mounting position and surface.</li> <li>• Assign at least two people to install the inverter.</li> </ul>
<b>Attention</b>	

### A. Installation process

This section describes the process for installing the 3PH 250KTL-350KTL-HV inverter

### B. Checks before installation

This section describes the checks to carry out on the outer packaging, on the inverter and its components.

### C. Installation tools

This section describes the tools needed to install the inverter and to make the electrical connections.

### D. Installation position

This section describes the characteristics of the installation site of the inverter.

### E. Moving the inverter

This section describes how to move the inverter to the installation site.

### F. Installing the inverter

This section describes the steps for mounting the inverter on the wall.

## 4.1. Installation process

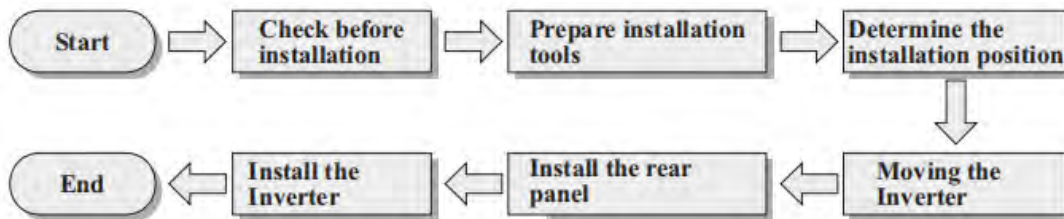


Figure 7 – Installation steps

## 4.2. Checks before installation

### Checking the outer packaging

Packaging materials and components may be damaged during transport. Therefore, please check the materials of the outer packaging before installing the inverter. Check the surface of the box for external damage such as holes or tears. If any kind of damage is found, do not open the box containing the inverter and contact the supplier and transport company as soon as possible.

It is recommended to remove the packaged materials from the box 24 hours before installing the inverter.

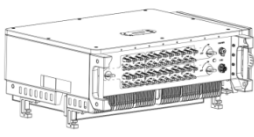

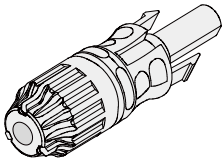
### Checking the product

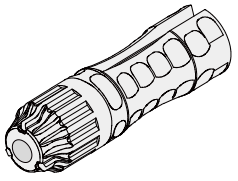
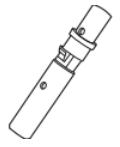
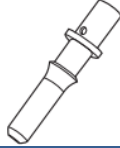
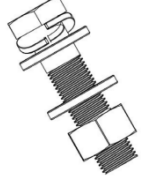





After removing the inverter from its packaging, check that the product is intact and complete. If any damage is found or components are missing, contact the supplier and transport company.

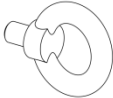
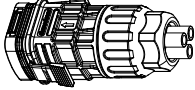
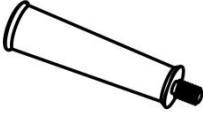
### Contents of the packaging

Carefully check the contents of the packaging before installation, making sure that no element inside the packaging is missing or damaged.

The package should contain the following components:


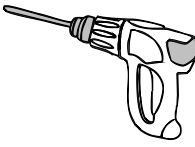

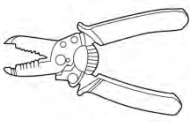
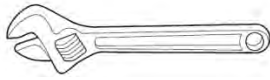

No.	Pictures	Description	Quantity
1		AZZURRO 3PH 250KTL-350KTL HV-Z0	1 PCS
2		Rear Panel	1 PCS
3		PV+ input connector	32PCS

4		PV- input connector	32PCS
5		PV+ metal pin	32PCS
6		PV- metal pin	32PCS
8		M12X30 Hexagon screws	4 PCS
9		M6*30 Hexagon screws	2 PCS
10		Manual	1PCS
11		Warranty Card	1PCS
12		Outgoing inspection report	1PCS
13	 <p> <small>GENTILE CLIENTE, TI RICORDIAMO DI ACCEDERE ALLA SEZIONE ESTENSIONE GARANZIA DEL SITO <a href="http://www.zucchetti.com">www.zucchetti.com</a> PER ESTENDERE LA GARANZIA DEL TUO INVERTER COME INDICATO NEI T&amp;C</small> </p> <p> <small>DEAR CUSTOMER, WE REMIND YOU TO ACCESS THE WARRANTY EXTENSION SECTION OF THE SITE <a href="http://www.zucchetti.com">www.zucchetti.com</a> TO EXTEND THE WARRANTY OF YOUR INVERTER AS WRITTE ON THE T&amp;C</small> </p>	Quality Certificate	1PCS

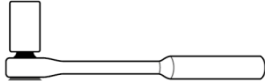
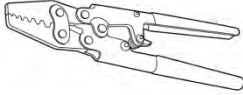



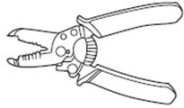
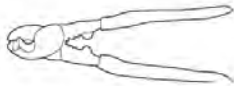
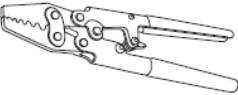
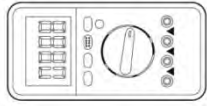

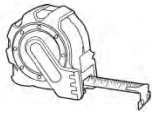
14		M12 lifting bolt	2PCS
15		COM 16pin connector	1PCS
16		auxiliary handle	4PCS

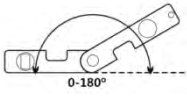
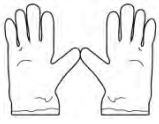


### 4.3. Installation tools

The following tools are required for installation of the inverter and electrical connections; therefore, they must be prepared before installation.

No.		Tool	Function
1		Hammer Drill Recommended drill bit: 12mm	To drill holes in the wall for fixing the bracket
2		Electric Drill Recommended ded: 12mm drill bits	To drill holes in the wall for fixing the bracket
3		Screwdriver	To screw and unscrew screws for the various connections
4		Wire stripper	To prepare the cables for wiring
5		Adjustable spanner (opening greater than 32 mm)	To tighten the bolts
6		6 mm Allen key	To screw the inverter to the wall-mounting bracket and to open the front cover of the inverter



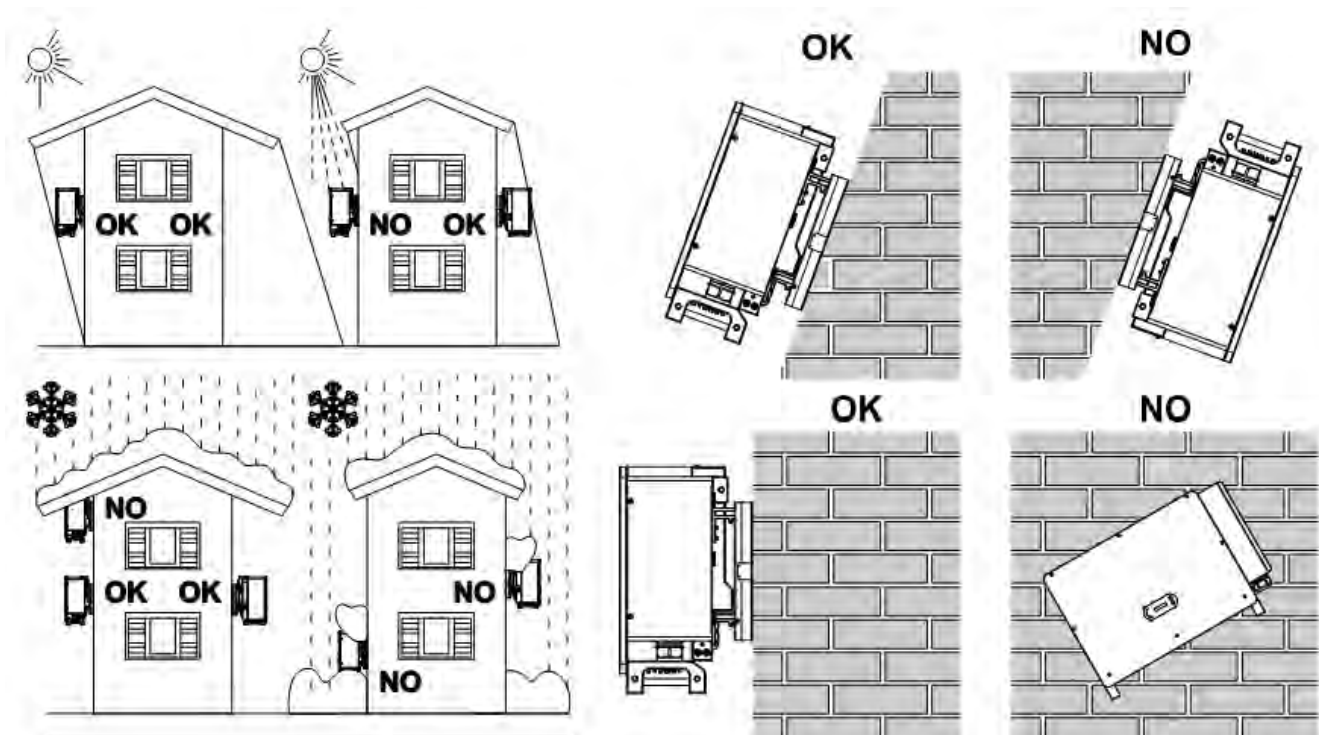
7		M5 socket wrench	To tighten the bolts
8		RJ45 crimping tool	To crimp the RJ45 connectors for the communication cables
9		Rubber hammer	To insert the expansion plugs into the wall holes
10		MC4 removal tool	To remove the DC connectors from the inverter
11		Diagonal pliers	To cut and tighten the cable ends
12		Wire stripping tool	To remove the outer sheath of the cables
13		Cable cutter	To cut the power cables
14		Crimping tool	To crimp the power cables
15		Multi-meter	To check the voltage and current values
16		Marker pen	To mark the wall for better fixing precision
17		Measuring tape	To measure distances

18		Level	To make sure the bracket is level
19		ESD gloves	Protective clothing
20		Safety goggles	Protective clothing
21		Protection mask	Protective clothing

#### 4.4. Installation position

Select a appropriate location to install the product to make sure the inverter can work in a high efficiency condition. When selecting a location for the inverter, consider the following:

Note: Install vertical or backward tilt within 0-75°, Do not install forward or upside down!



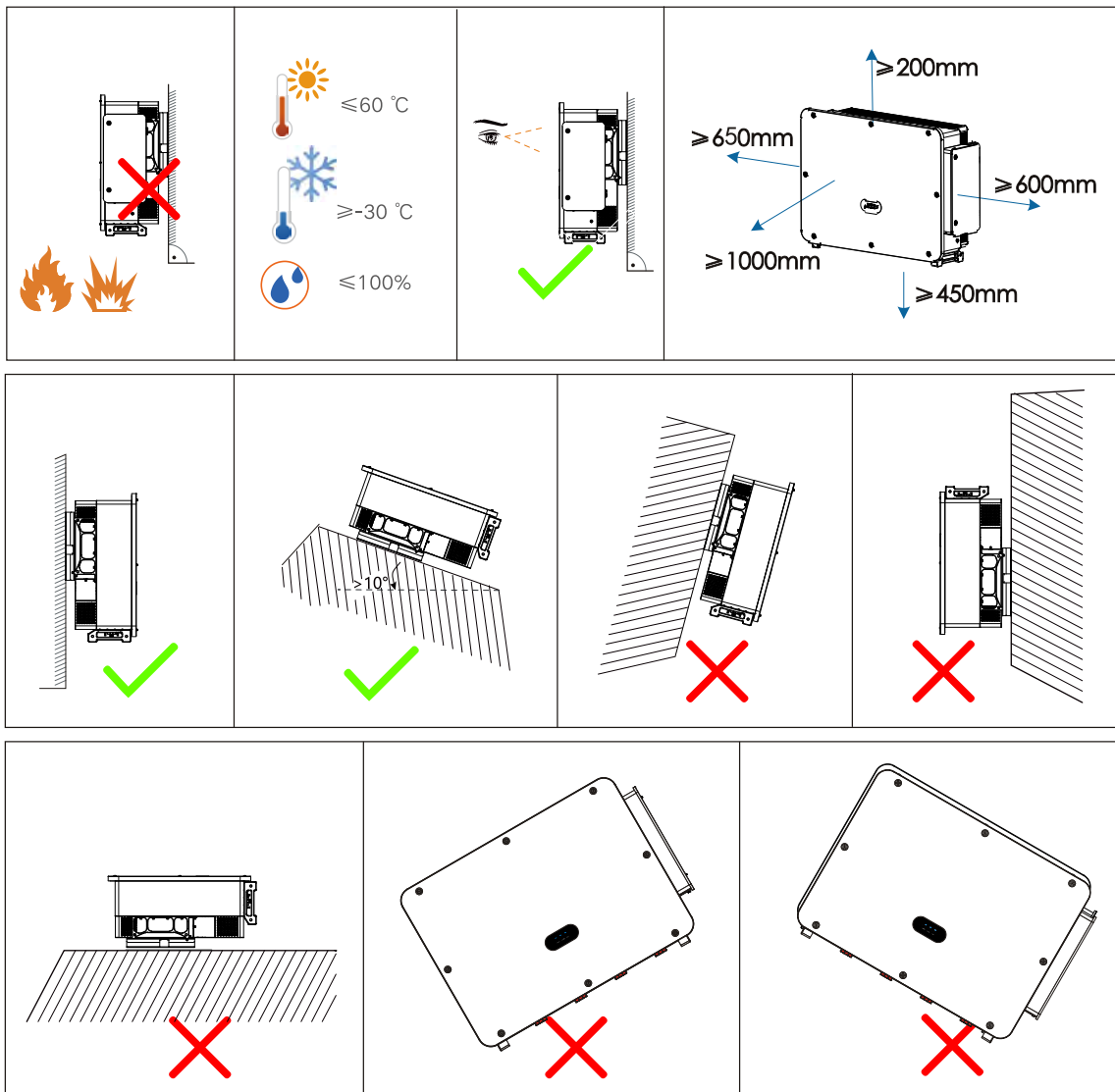
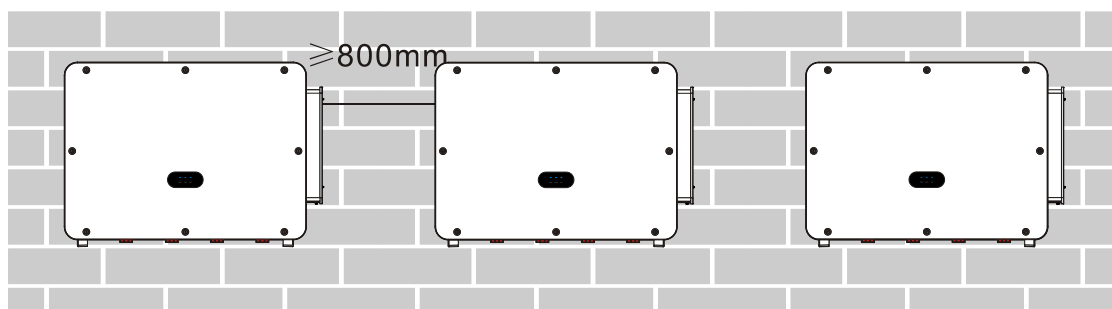
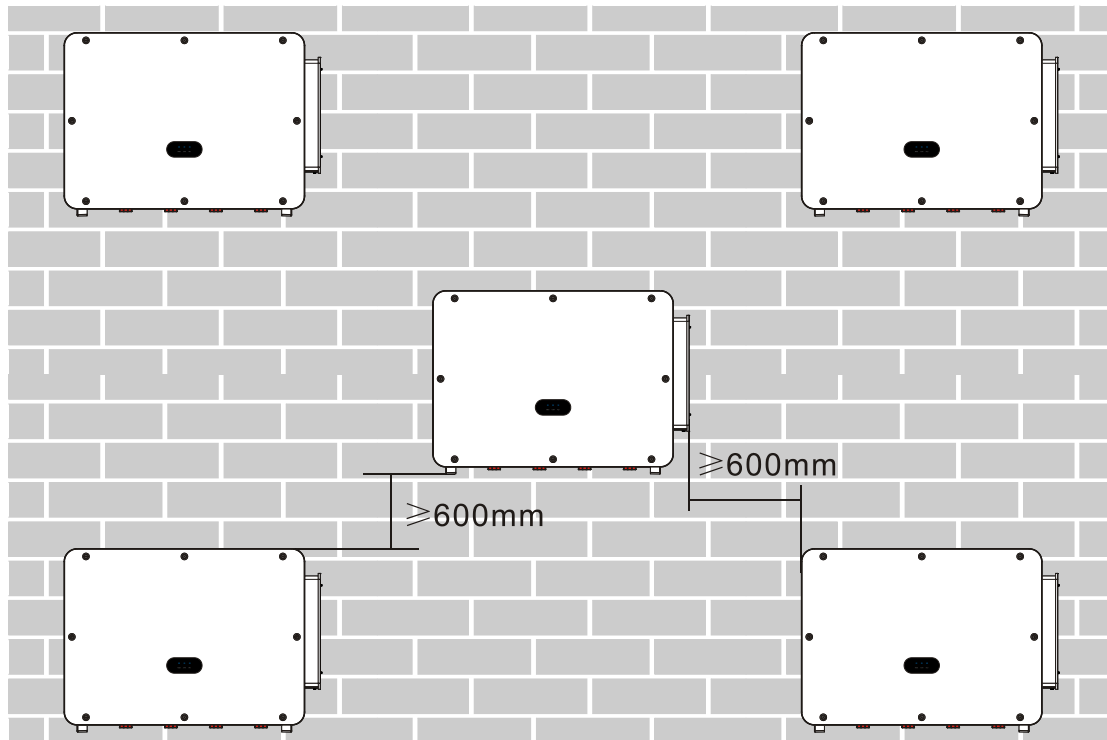


Figure 9 - Requirements for installing a single inverter





**Figure 8 – Requirements for installing multiple inverters**

**Note:** For safety reasons, ZCS S.p.A. and/or its partners may not carry out any technical repairs or maintenance work, or move the inverter from and to the ground if it is installed at a height of more than 180 cm from the ground.

Inverters installed at higher heights must be moved to the ground before they can be repaired or serviced.

#### 4.5. Moving the 3PH 250KTL-350KTL HV-Z0 inverter

This section describes how to move the inverter correctly

- 1) When opening the packaging, insert your hands into the slots on both sides of the inverter and take a hold of it as shown in Figure below. Two operator are needed to carry out this operation in order to ensure the safety of people and the correct handling of the inverter.

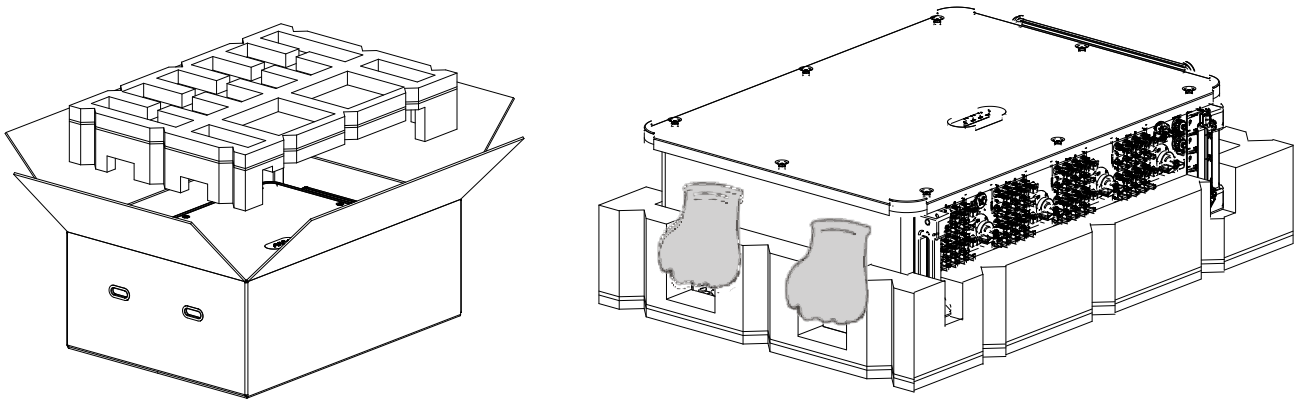



Figure 9 - Removing the inverter from its packaging

- 2) Lift the inverter from its packing box and move it to the installation position.

	<ul style="list-style-type: none"> <li>• To prevent damage and personal injury, hold the inverter firmly when moving, as it is a heavy piece of equipment.</li> <li>• Do not position the inverter with the input/output terminals in contact with other surfaces, as these are not designed to support the weight of the inverter. Always position the inverter horizontally.</li> <li>• When placing the inverter on the floor, make sure to place a support under the unit to protect its front door.</li> <li>• Use auxiliary handle inside the package for moving the inverter. After use, keep it well for future usage.</li> </ul>
<b>Attention</b>	



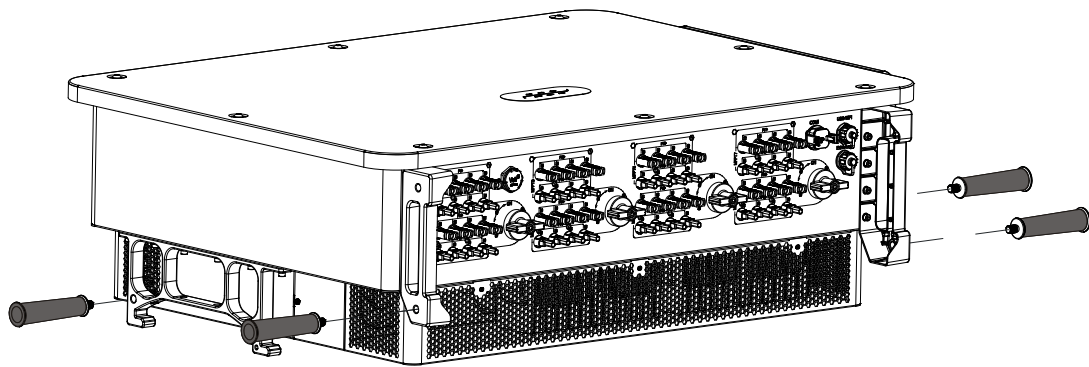


Figure 10 - Auxiliary handle position

### 3) Lifting equipment.

Tighten the screws of two M12 rings into the inverter sides according to the instruction diagram below (Note: M12 rings need self-preparation).

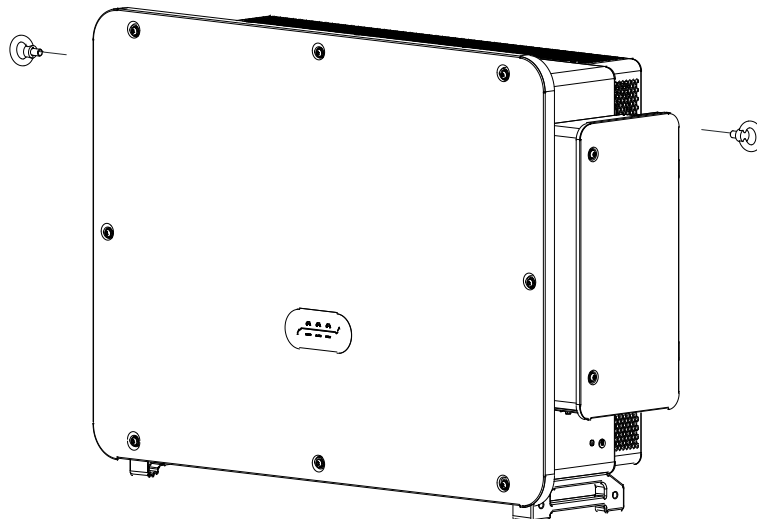
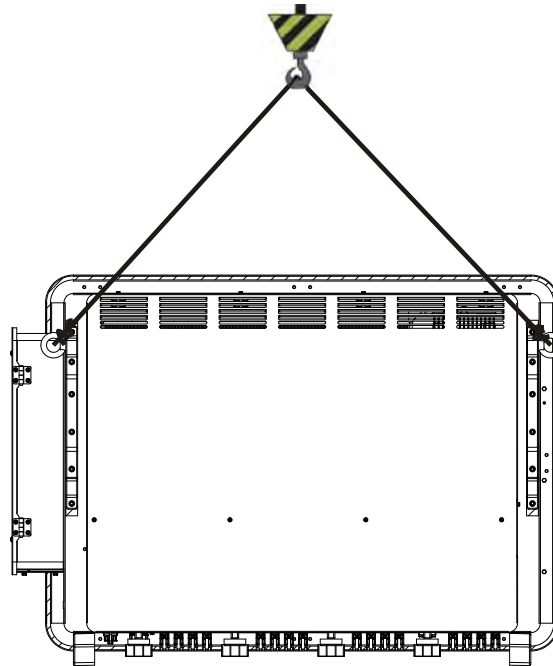


Figure 11 - Installation of rings

Fastened and tied the rope through two rings. Lifting inverter 50 mm above ground by using lifting equipment, check the tightening device of the hoisting ring and rope. After confirming that the binding connection is secure, lift the inverter to the destination.



**Attention**

- **Keep balance when lifting the inverter, avoid to crash on wall or other objective.**
- **Stop working in bad weather condition such as raining, heavy fog, winding.**

#### 4.6. Installing the 3PH 250KTL-350KTL HV-ZO inverter

Always make sure the inverter is free of any electrical connections before installing the inverter. Before drilling, make sure that you avoid any utility alignments in the wall to avoid any hazards!

- 1) Placed the rear panel on the mounting wall, determine the mounting height of the bracket and mark the mounting poles accordingly. Drilling holes by using Hammer Drill, keep the hammer drill perpendicular to the wall and make sure the position of the holes should be suitable for the expansion bolts.

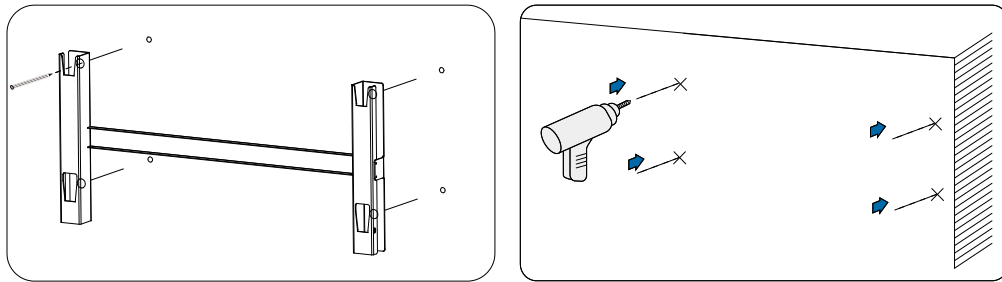


Figure 12 - Drilling holes on the mounting wall

- 2) Insert the expansion bolt vertically into the hole (Recommended Specifications: M10\*90).

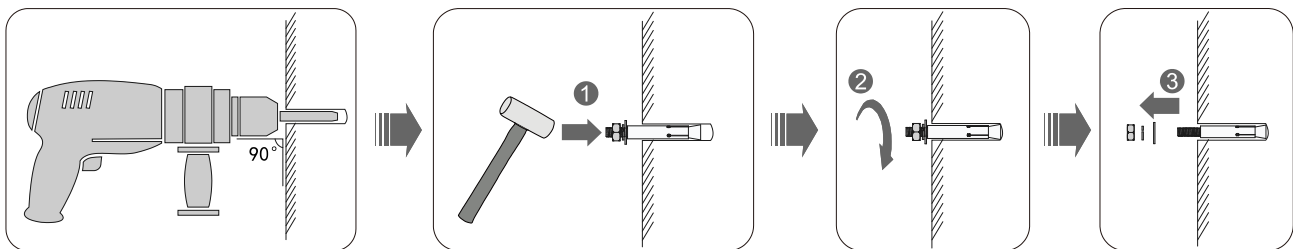


Figure 13 - Screws into the holes

- 3) Align the rear panel with the hole positions, fix the rear panels on the wall by tightening the expansion bolt with the nuts.

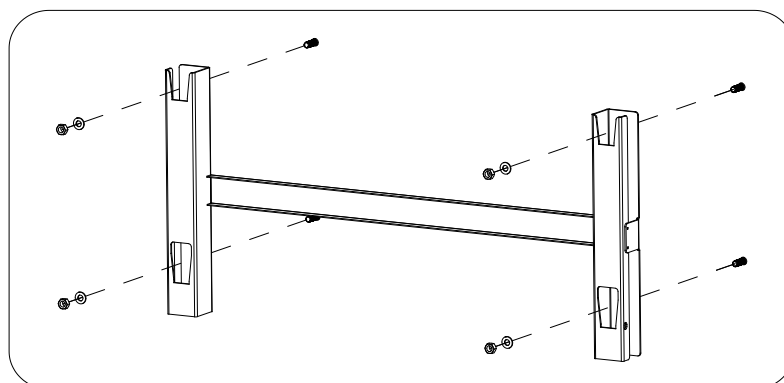


Figure 14 - Install rear panel

- 4) Lift the inverter and hang it on the rear panel, and fixing both side of inverter with M6 screw (accessories).

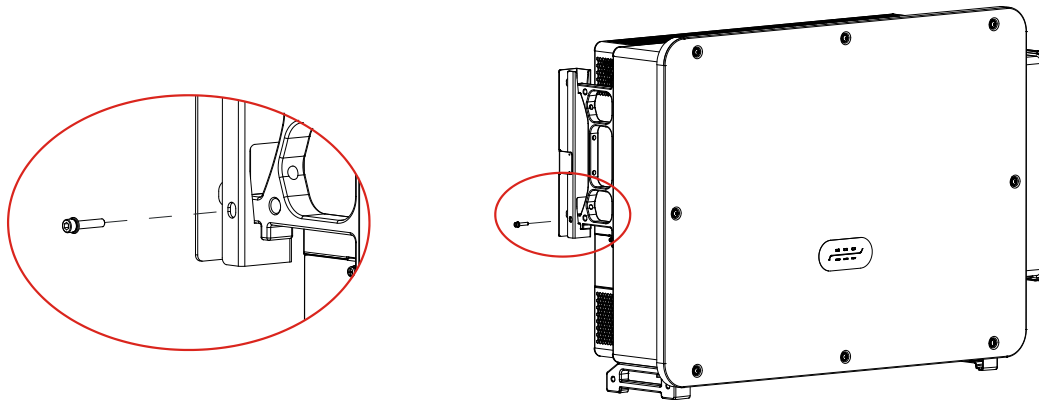


Figure 15 - Fix inverter

- 5) Use wall mount bracket, ensure the pole position are in same level by using level rule and take a mark with maker.

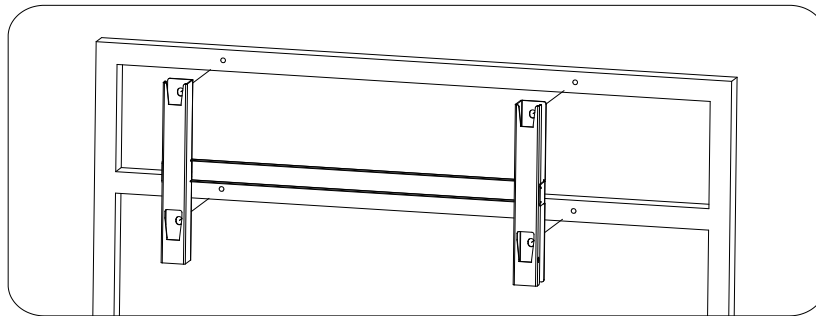


Figure 16 - Ensure hole position

- 6) Drilling hole by using Hammer Drill, recommend to do a stain proofing.

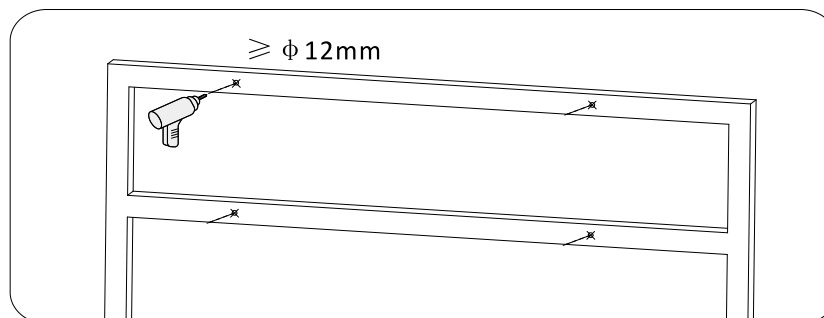
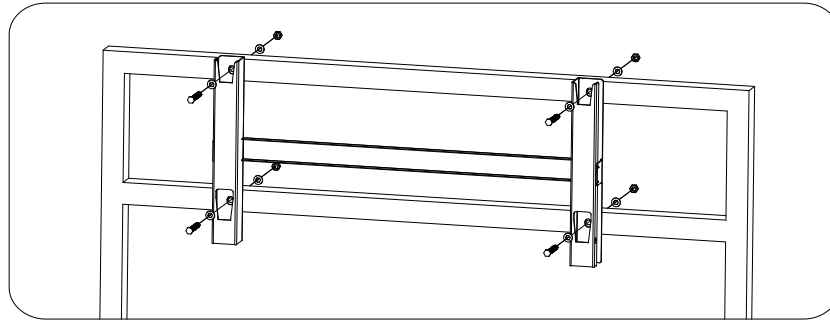


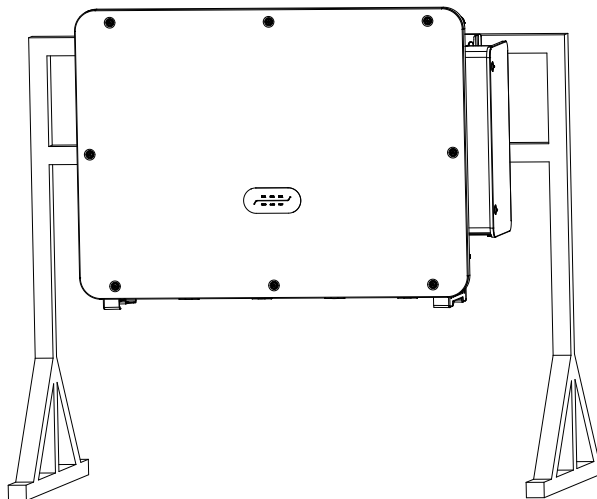
Figure 17 - Drilling holes

7) Use M12 screw and M12 flat washer to secure the wall bracket (Note : M10\*50 screw and M10 flat washer need self-preparation).

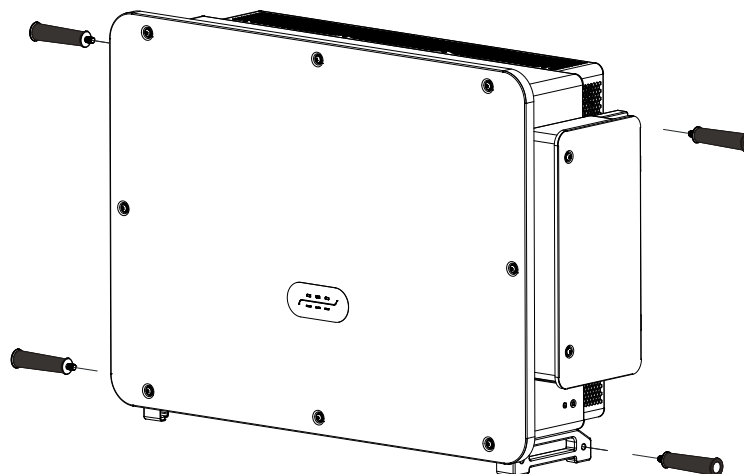


**Figure 18 - Fix wall bracket**

8) Repeat step 4).



Note: if height between ground and bracket is less than 1.5m, use auxiliary handle for installation. Otherwise, use lifting equipment.



**Figure 19 - Installation position of auxiliary handle**








## 5. Electrical connections

### General information in this chapter

This chapter describes the electrical connections of the 3PH 250KTL-350KTL HV-Z0 inverter. Carefully read this section before connecting the cables.

**NOTE:** Before making any electrical connections, ensure that the DC and AC circuit breakers are open. Remember that the accumulated electrical charge remains in the inverter capacitor after the DC and AC circuit breakers have been switched off. Therefore, it is necessary to wait at least 25 minutes to allow the capacitor to discharge completely.

	<p><b>The inverter must be installed and serviced by professional technicians or electricians.</b></p> <p><b>During electrical operations, the professional must wear protective equipment.</b></p>
<b>Attention</b>	
	<p><b>Before the electrical connection, use opaque material to cover the PV modules or disconnect PV string DC switch. PV arrays will produce dangerous voltage if it is exposure under sun.</b></p> <p><b>Do not close the AC/DC circuit breaker before completing the electrical connection and prevent misconnection.</b></p>
<b>Danger</b>	
	<p><b>The maximum open-circuit voltage of the photovoltaic string must be less than 1500 V.</b></p> <p><b>The 3PH 250KTL-350KTL HV-Z0 has 6-8 independent input channels (MPPT); all the photovoltaic modules connected to them must be of the same model and brand, and must be positioned with the same orientation (solar azimuth and inclination angle).</b></p> <p><b>The cables used in the PV system must be firmly connected, undamaged, well insulated and of the appropriate size.</b></p>
<b>Note</b>	

#### 4.1. Electrical connections

Describes the process for making the electrical connections.

#### 4.2. Terminal connector

Introduce inverter terminal port layout.

#### 4.3. Connecting the PNGD cable (grounding)

Describes the connection of the ground cable (PGND) for the ground of the inverter.

#### 4.4. Connecting the AC output power cables

Describes the connection of the inverter to the AC grid using the AC power cables (following the granting of the grid connection by the distributor).

#### 4.5. Connecting the DC input power cables

Describes the connection of the photovoltaic strings to the inverter using the DC power cables.

#### 4.6. Recommended wiring methods

Introduce Recommended wiring methods.

#### 4.7. Connecting the communication cables

Introduce the propose WIFI/USB, COM and how to connect WIFI/USB port.

#### 4.8. Safety check

Before operate inverter, check the PV array, inverter DC side safety connection and AC side safety connection.

### 5.1. Electrical connections

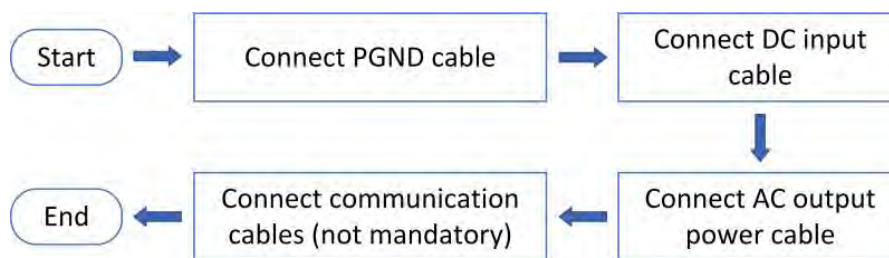
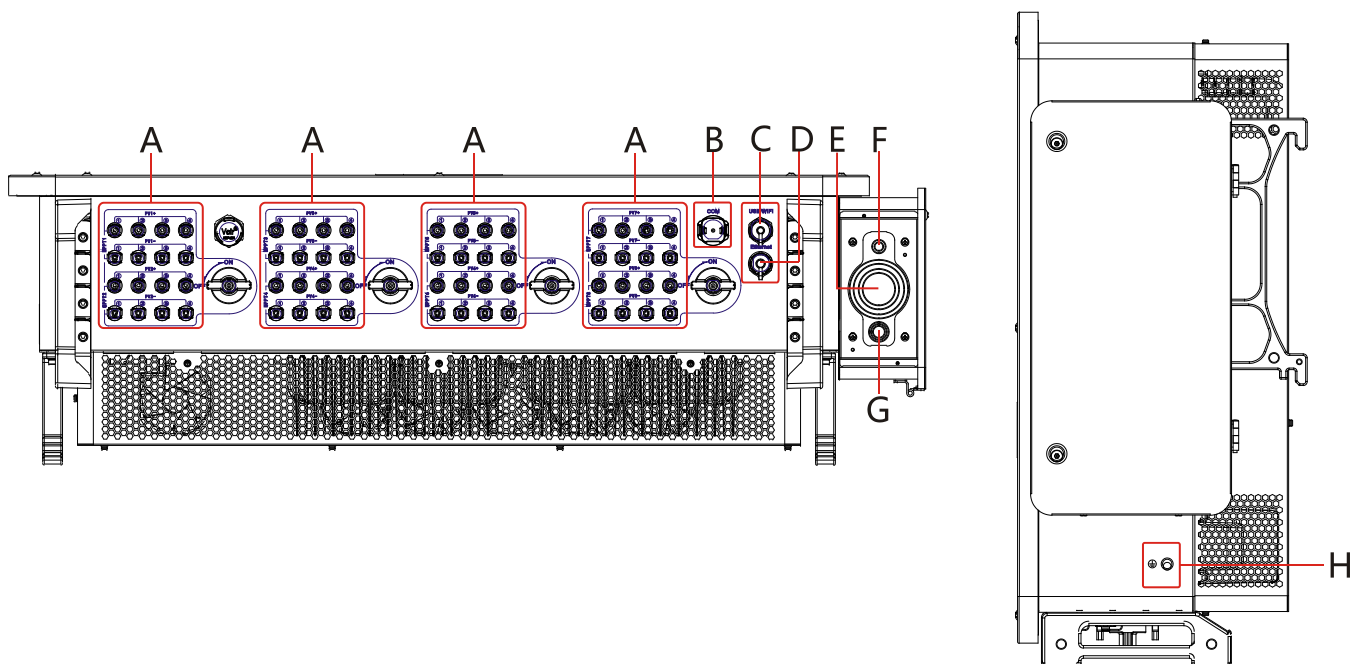



Figure 20 - Flowchart for connecting cables to the inverter

### 5.2. Terminal connector

Connector description as below:




\*take picture as reference

No	Name		Description
A	DC input terminals	PVX+/PVX-	PV connector
B	RS485	COM	RS485 Communication port/ DRMs port
C	USB port	USB/WIFI	USB port
D	RJ45	Ethernet	Ethernet port
E	AC output terminals		AC output terminal
F	Tracking Axis Power Terminal		Tracking System Power Wiring
G	Grounding		Connecting terminal of the ground , choose at least one for grounding connection
H	Grounding		Reliable grounding for inverters

\*Note: Lock the screw to limit the torque of the DC switch, making it impossible to twist the DC switch from OFF to ON, or ON to OFF. Remove the screw before turning the DC switch from OFF to ON or ON to OFF.

### 5.3. Connecting PNGD cables (grounding)

Connect the 3PH 250KTL-350KTL HV-Z0 inverter to the ground electrode using ground protection cables (PGND).

	<p>The inverter does not have a transformer, therefore the positive and negative polarities of the photovoltaic string do NOT need to be grounded. Otherwise, the inverter may fail. All non-current-carrying metal parts (such as the PV module frame, PV rack, housing of the combiner box, and housing of the inverter) in the PV power system must be connected to the ground.</p>
<b>Attention</b>	

#### Prerequisites:

Preparation: prepare the grounding cable (recommend  $S/2 \text{ mm}^2$  ('S' is the cross-sectional area of the AC output cables) yellow-green outdoor cable).

#### Procedure:

- 1) Remove the insulation layer with an appropriate length using a wire stripper shown in figure below.

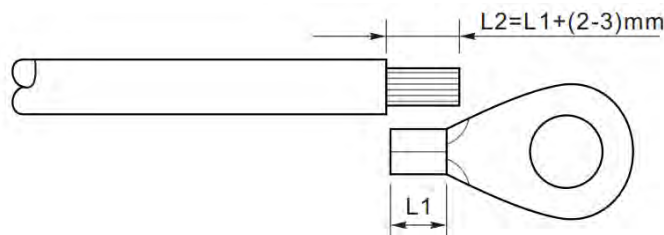


Figure 21 - Preparing the ground cable (1)

**Note:** L2 is approximately 2-3 mm longer than L1.

- 2) Insert the exposed core wires in the OT terminal and crimp them using a crimping tool, as shown in figure below. Recommend using OT terminal: OTM8, Cable:  $\geq 16\text{mm}^2$ .

**Note 1:** L3 is the length between the insulation layer of the ground cable and the crimped part. L4 is the distance between the crimped part and the conductor wires protruding from the crimped part.

**Note 2:** The cavity formed after the conductor has been crimped must completely wrap the conductor wires. The core of the wire must be in close contact with the terminal.

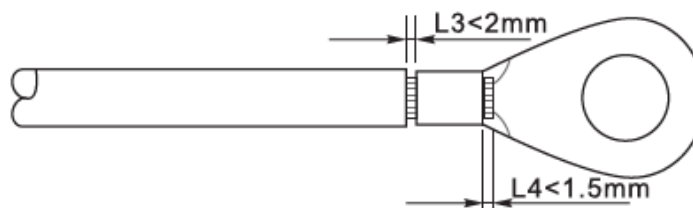
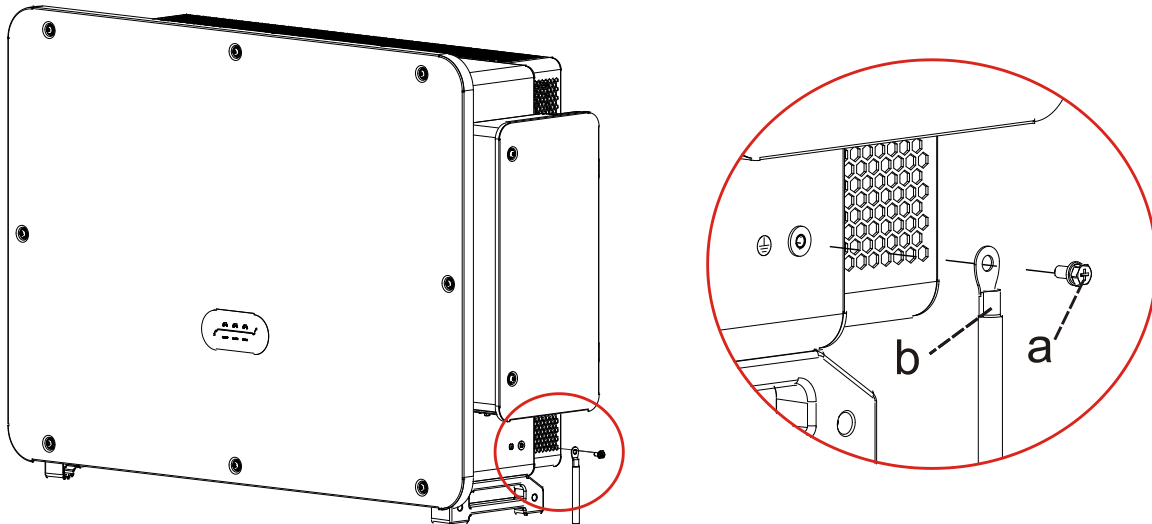


Figure 22 - Preparing the ground cable (2)

- 3) Remove the screw from the bottom side of inverter (Shown as figure), connect the grounding cable to the grounding point and tighten the grouping screw. Torque is 6-7Nm.



a.M8hexagon screw b. grounding cable

**Figure 23 – Inverter external grounding instruction diagram**

**Note:** To ensure the anti-corrosion performances of the ground terminals, apply silica gel on them after connecting the ground cable.

## 5.4. Connecting the AC output power cables

Inverter has a standard and integrated residual current monitoring unit (RCMU), when inverter detected leakage current excess 300mA, it will cut off with utility grid for protection. For external Residual Current Device (RCD), the rated residual current shall be 300mA or higher.

### Precondition:

Inverter AC side should connect a three phase circuit current to ensure inverter can be cut off with utility grid for abnormal condition.

The AC cable need to meet the requirement of local grid operator.

### Cable connection procedure

Open the wiring box.

- Use M6 driver to unscrew the two screws on the wiring box.
- Open wiring box cover.

### Note:

- Forbid to open then main board cover of inverter.
- Before open the wiring box, please ensure there is not DC and AC connection.
- If open the wiring box on snowing or raining day, please take protective measures to avoid the snow and rain enter wiring box. Otherwise, should not open the wiring box.
- Please do not unused screw in the wiring box.
- Step1: Use M6 driver to unscrew the two screws on the wiring box.
- Step 2: Open wiring box cover.

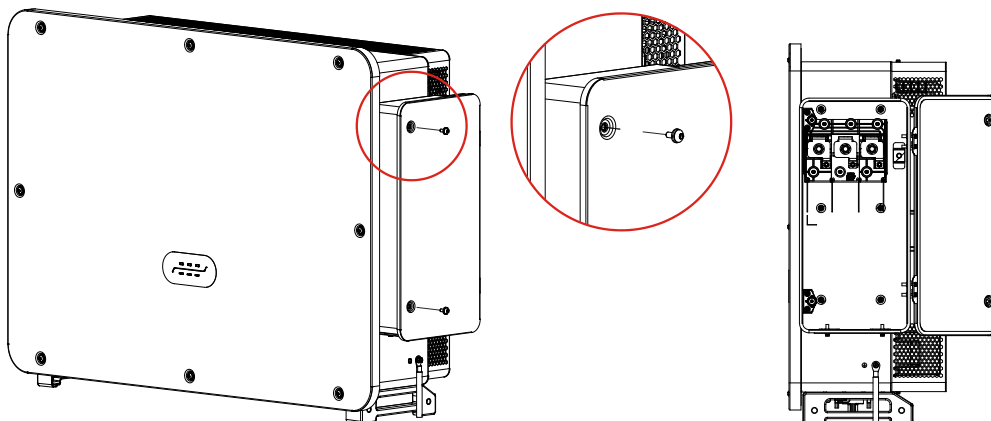


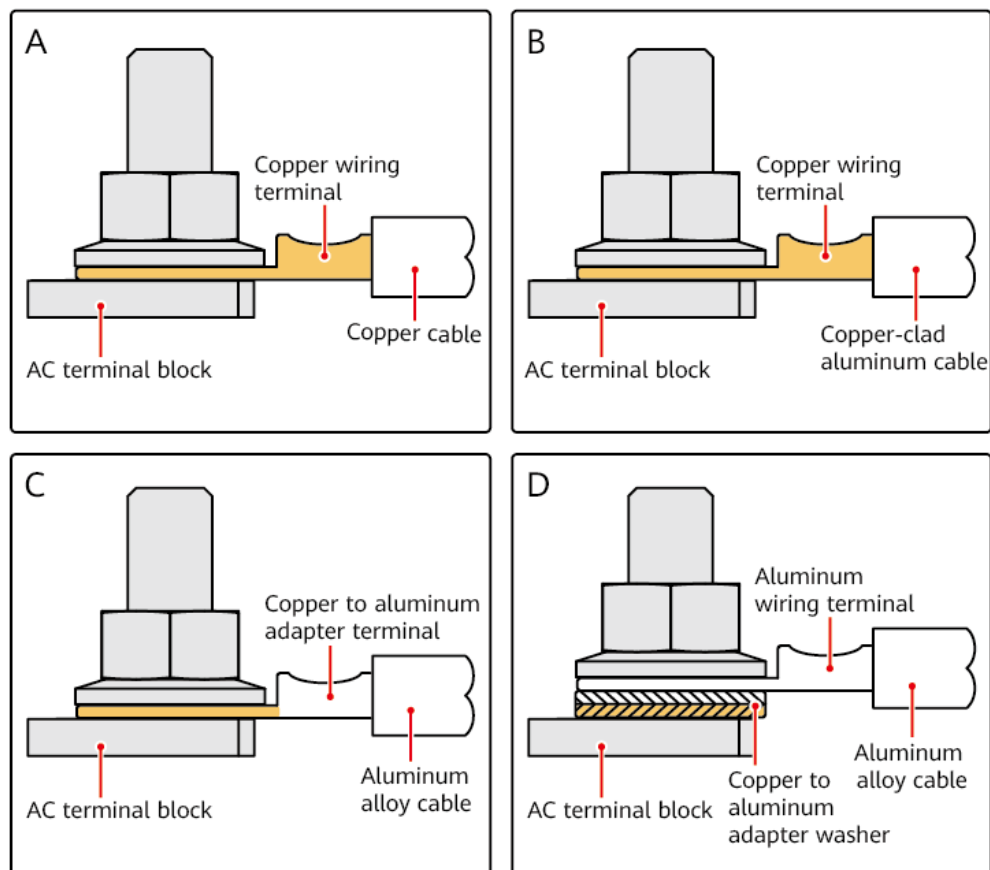
Figure 24 -Open wiring box



## Wiring Terminal and Precautions

### Note:

- Before connect to grid, please ensure the grid voltage and frequency of local grid meet the requirement of inverter , any question please seek local grid company for help.
- Inverter can only connect to grid after get the permission from local grid company
- Should not connect any loads between inverter and AC circuit breaker
- OT/DT Requirement
- When use copper core cable, please use copper terminal connector
- When use copper clad aluminum cable, please use copper terminal connector
- When use aluminum core cable, please use Copper and aluminum transition terminal connector or aluminum terminal connector
- If an aluminum alloy cable is used, use copper-aluminum transition wiring terminals, or aluminum wiring terminals along with copper-aluminum transition spacers.



IS03H00062

Figure 25 - OT/DT Requirement for terminal connection

CAUTION: Direct contact between copper and aluminium conductors will cause galvanic corrosion and affect the reliability of the electrical connection.

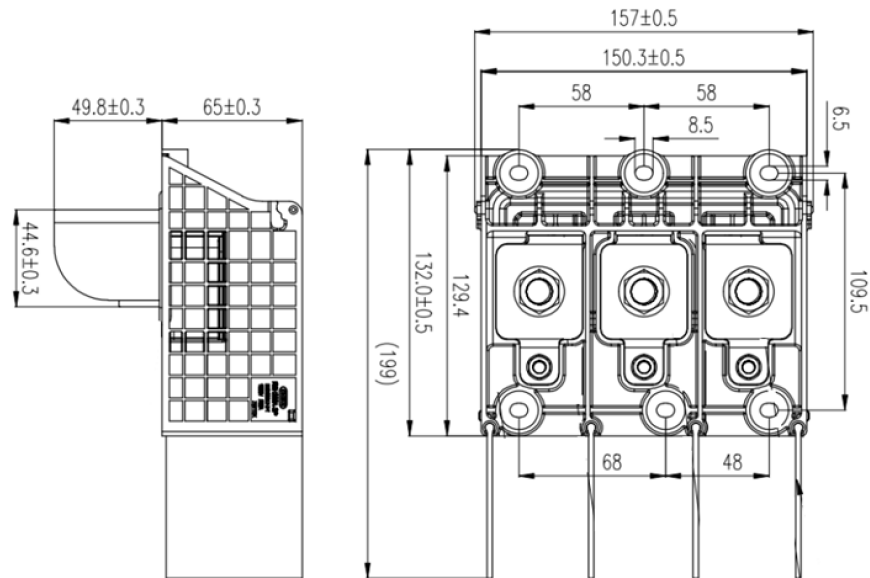


Figure 26 – AC Terminal size

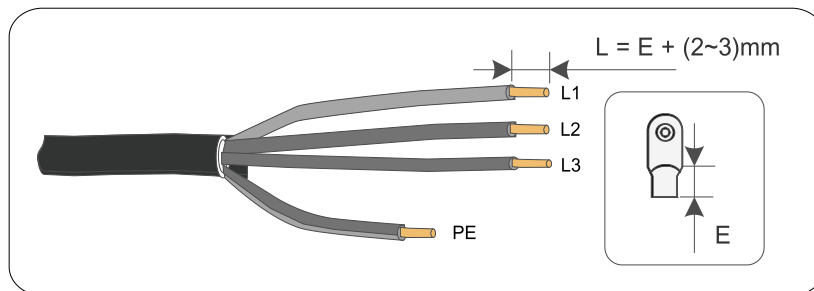
### Wring Procedure

The section will use a five core wire as a sample, four core wire has same connection process. The table below presents recommend AC cable size.

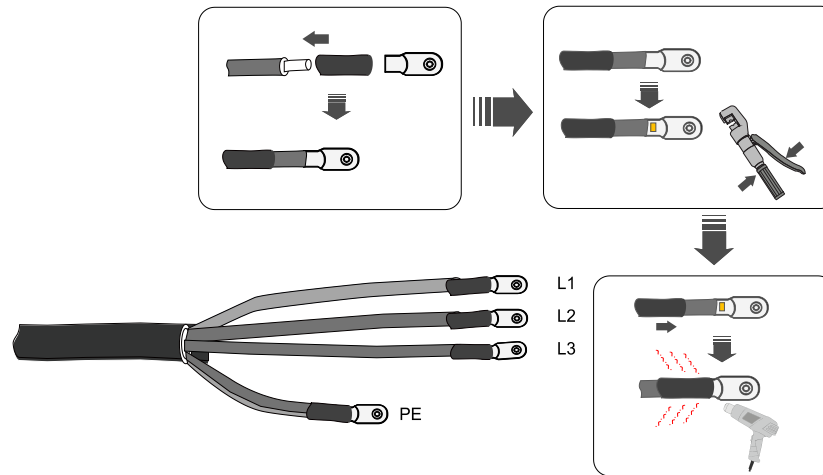
Name	Type	Area(mm <sup>2</sup> )	Outer Diameter
<b>AC output power cables (multi-core)</b>	<ul style="list-style-type: none"> <li>✓ If the ground point on the enclosure is used, three-core (L1, L2, and L3) outdoor cables and M12 OT/DT terminals (L1, L2, and L3) are recommended.</li> <li>✓ If the ground point in the maintenance compartment is used, four-core (L1, L2, L3, and PE) outdoor cables, M12 OT/DT terminals (L1, L2, and L3), and M10 OT/DT terminals (PE) are recommended. You do not need to prepare a PE cable.</li> </ul>	<ul style="list-style-type: none"> <li>✓ Copper cable: S: 120–150mm<sup>2</sup> Sp ≥ S/2</li> <li>✓ Aluminum alloy cable or copper-clad aluminum cable: S: 150–240 mm<sup>2</sup> Sp ≥ S/2</li> </ul>	24-66mm <sup>2</sup>

<p><b>AC output power cables (single-core)</b></p>	<p>✓ (Recommended) Single-core outdoor cable and M12 OT/DT terminal</p>	<p>✓ Copper cable: S: 120–150 mm<sup>2</sup> Sp ≥ S/2</p> <p>✓ Aluminum alloy cable or copper-clad aluminum cable: S: 150–400 mm<sup>2</sup> Sp ≥ S/2</p>	<p>14-40mm<sup>2</sup></p>
<p>The value of Sp is valid only if the conductors of the PE cable and AC power cable use the same material. If the materials are different ensure that the conductor cross-sectional area of the PE cable produces a conductance equivalent to that specified in this table. The specification of the PE cable are subject to this table or calculated according to IEC 60364-5-54</p>			

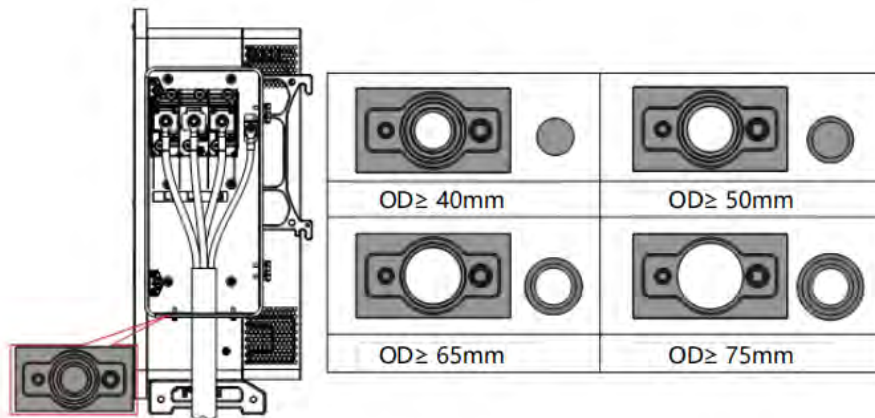
- 1) Open the cover.
- 2) Turn OFF the AC circuit breaker and secure against reconnection.
- 3) Unscrew the nut of the AC terminal block and select the sealing ring according to the outer diameter of the cable. Insert the nut, sealing ring into the cable in sequence.
- 4) Remove the insulation layer of an appropriate length according to figure below.



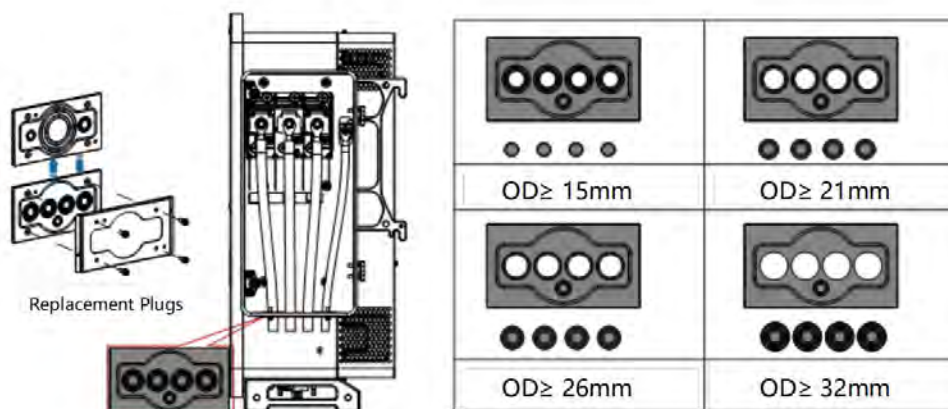
- 5) Crimp the Terminal.



- 6) Depending on the grid configuration, connect L1, L2, L3 and N to the terminals according to the label and tighten the screw on the terminal using a screwdriver.



- 7) Single core wire wiring diagram: Select single-core wire, before wiring, you need to replace the already installed in the machine plugs with the single-core over-wire plugs supplied with the shipment.



**Note:**

- Phase lines use M12 terminal connector, PE line use M8 terminal connector.

## 5.5. Connecting the DC input power cables

Connect the 3PH 250KTL-350KTL HV-Z0 inverter to the photovoltaic strings using DC input power cables. Select the input mode: the 3PH 250KTL-350KTL HV-Z0 inverter has 6-8 MPPTs, which can be set independently or in parallel, depending on how the system was designed. The user can choose the appropriate MPPT operating mode.

### Independent mode (default):

If the strings are independent (e.g. installed on two separate flaps), the input model must be set to “independent mode.”

### Parallel mode:

If the strings are connected in parallel, the input mode must be set to “parallel mode.”

### Note:

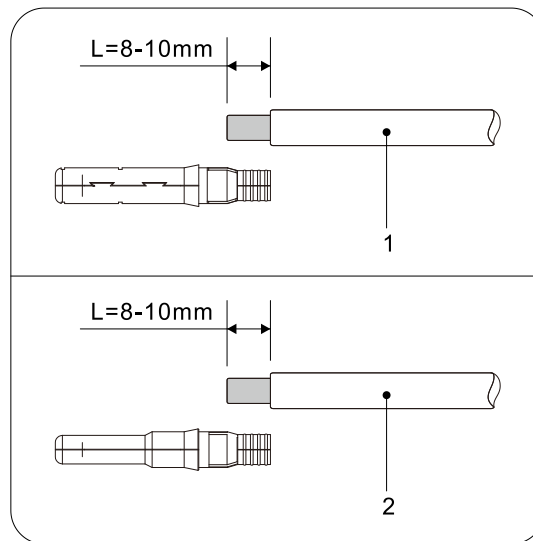
- Connecting PV strings into inverter must following the below procedure. Otherwise, any faulty cause by inappropriate operation will be including in the warranty case.
- Ensure the maximum short circuit current of PV strings should less than the maximum inverter DC current input. And three “DC switch” is in OFF position. Otherwise, it may cause high voltage and electric shock.
- Ensure PV array have good insulation condition in any time.
- Ensure same PV string should have the same structure, including: same model, same number of panels, same direction, same azimuth.
- Ensure PV positive connector connect to inverter positive pole, negative conenctor connect to inverter negative pole
- Please use the connectors in the accessories bag. The damage cause by incorrect is not including in the warranty.

### Context

Cross section (mm <sup>2</sup> / AWG)		Outer diameter of cable (mm)
Range	Recommended value	
4.0-6.0	4.0	4.5 - 7.8

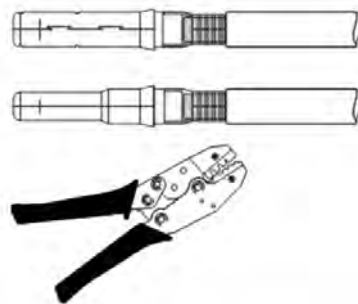
Figure 27 – Recommend DC cable size

- 1) Find the metal contact pins in the accessories bag, connect the cable according below figure (1.Positive cable, 2. negative cable).

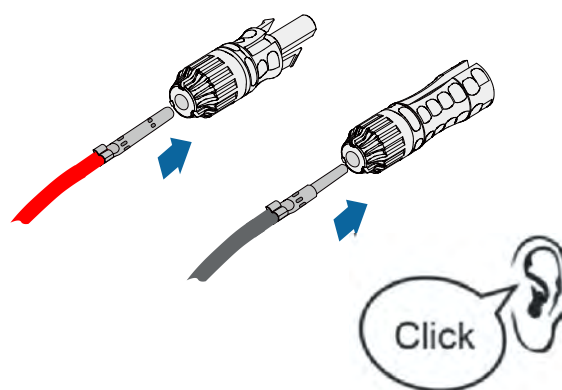


**Figure 28 - DC cable connection**

- 2) Crimp the PV metal contact pin to the striped cable using a proper crimping pliers.



- 3) Insert wire into the connector cap nut and assemble into the back of male or female plug, When you heard a “click”, the pin tact assembly is seated correctly. (3. Positive Connector, 4. negative connector).



- 4) Measure PV voltage of DC input with multimeter, verify DC input cable polar and connect DC connector with inverter until hearing a slight sound indicated connection succeed.



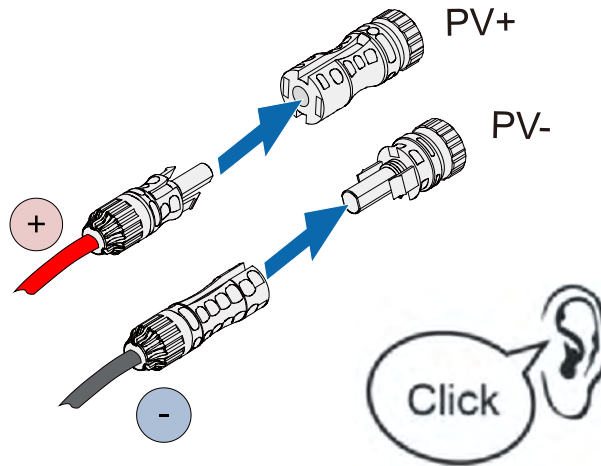
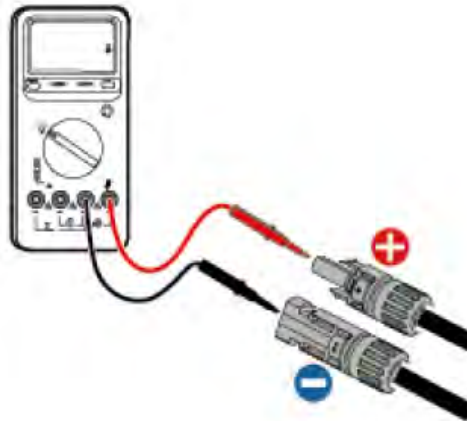


Figure 29 – DC cable connection




**Note: Please use multimeter to make sure the PV array positive pole and negative pole!**

Dealing : If need to remove the PV connector from inverter side, please use the Removal Tool as below diagram, move the connector gently.

### Removal procedure

To remove the positive and negative connectors from the inverter, insert a removal tool in the bayonet coupling and press the tool with adequate force, as shown in the figure below.

	<p><b>Before removing the positive and negative connectors, make sure that the inverter's circuit breaker is switched off. If not, the direct current may cause an electric arc that could result in a fire</b></p>
<p><b>Warning</b></p>	

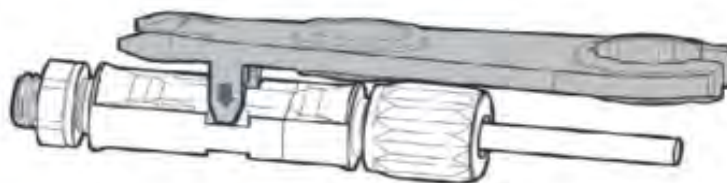


Figure 30 – Removing the DC connector

## 5.6. Recommended Wiring Methods

The inverter has a total of 32 DC input terminals, of which the branches of MPPT1 to MPPT2 are controlled by DC SWITCH 1, the branches of MPPT3 to MPPT4 are controlled by DC SWITCH 2, the branches of MPPT5 to MPPT6 are controlled by DC SWITCH 3, and the branches of MPPT7 to MPPT8 are controlled by DC SWITCH 4.

It is recommended that all PV input terminals be divided equally among MPPT1 to MPPT8 branches, and the maximum current of each MPPT is controlled at 60A, and the maximum current of each branch of MPPT is 20A.

For example, when the number of input strings is 20 to 31, the recommended connection of DC input terminals is as follows.

Strings number	Terminal Selection	Strings number	Terminal Selection
20	MPPT1/MPPT3/MPPT5/MPPT7 are connected to 3 strings respectively, MPPT2/MPPT4/MPPT6/MPPT8 are connected to 2 strings respectively.	26	MPPT1/MPPT8 are connected to 4 strings respectively, MPPT2/MPPT3/MPPT4/MPPT5/MPPT6/MPPT7 are connected to 3 strings respectively.
21	MPPT1/MPPT3/MPPT5/MPPT7/MPPT8 are connected to 3 strings respectively, MPPT2/MPPT4/MPPT6 are connected to 2 strings respectively.	27	MPPT1/MPPT7/MPPT8 are connected to 4 strings respectively, MPPT2/MPPT3/MPPT4/MPPT5/MPPT6 are connected to 3 strings respectively.
22	MPPT1/MPPT2/MPPT3/MPPT5/MPPT7/MPPT8 are connected to 3 strings respectively, MPPT4/MPPT6 are connected to 2 strings respectively.	28	MPPT1/MPPT3/MPPT5/MPPT7 are connected to 4 strings respectively, MPPT2/MPPT4/MPPT6/MPPT8 are connected to 3 strings respectively.
23	MPPT1/MPPT2/MPPT3/MPPT4/MPPT5/MPPT7/MPPT8 are connected to 3 strings respectively, MPPT6 are connected to 2 strings respectively.	29	MPPT1/MPPT3/MPPT5/MPPT7/MPPT8 are connected to 4 strings respectively, MPPT2/MPPT4/MPPT6 are connected to 3 strings respectively.
24	MPPT1~MPPT8 are connected to 3 strings respectively,	30	MPPT1/MPPT2/MPPT3/MPPT5/MPPT7/MPPT8 are connected to 4 strings respectively, MPPT4/MPPT6 are connected to 3 strings respectively.
25	MPPT8 are connected to 4 strings respectively, MPPT1~MPPT7 are connected to 3 strings respectively,	31	MPPT1/MPPT2/MPPT3/MPPT4/MPPT5/MPPT7/MPPT8 are connected to 4 strings respectively, MPPT6 are connected to 3 strings respectively.

## 5.7. Connecting the communication cables

**Note:**

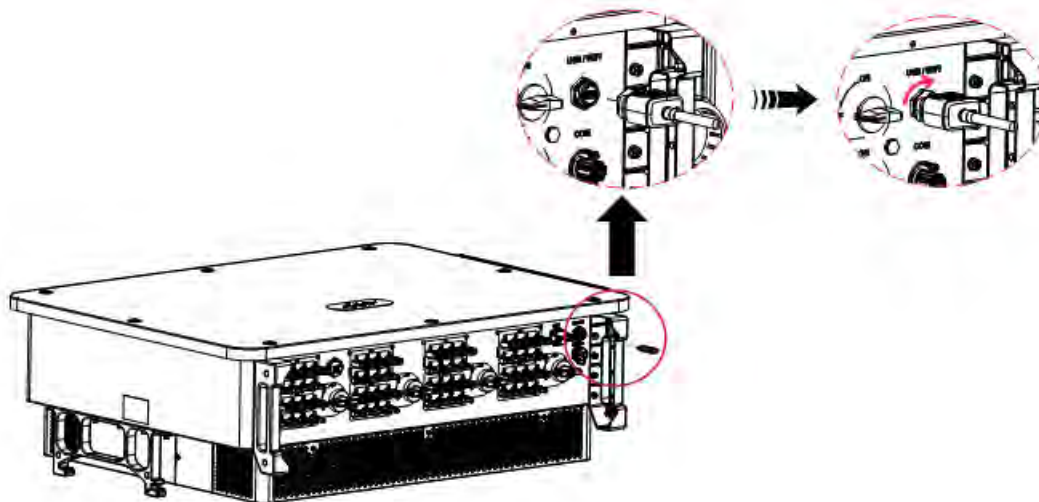
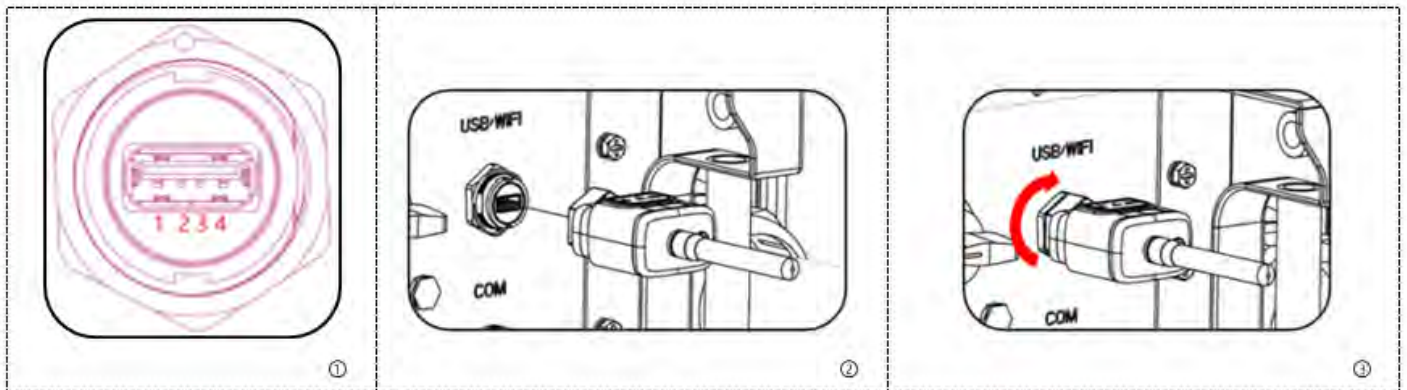
When layout the wiring diagram, please separate the communication wiring and power wiring in case the signal be affected.

### USB/Wifi Port

Port Description :

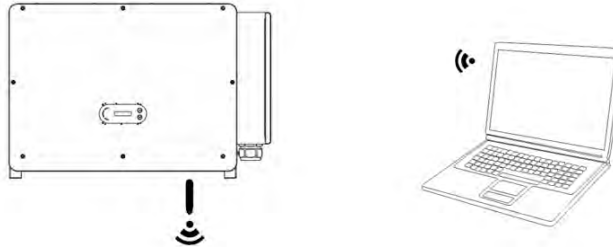
USB/WIFI port	USB: USB PORT	Use for updating the software
	WIFI: WIFI/GPRS/ETHERNET PORT	Use for connect WiFi/GPRS/Ethernet for data transmission

**Procedure:**



## WIFI/GPRS/Ethernet

By the USB acquisition stick (WIFI/GPRS/Ethernet), transfer the inverter power output information, alarm information, operation state to the PC terminal or local data acquisition device, then uploaded to the server. Register remote monitoring of AZZURRO ZCS 250/350KTL HV-Z0 at its relevant website or APP according to monitoring deviceSN.



## COM-Multi function communication port

The table below presents recommend com cable size.

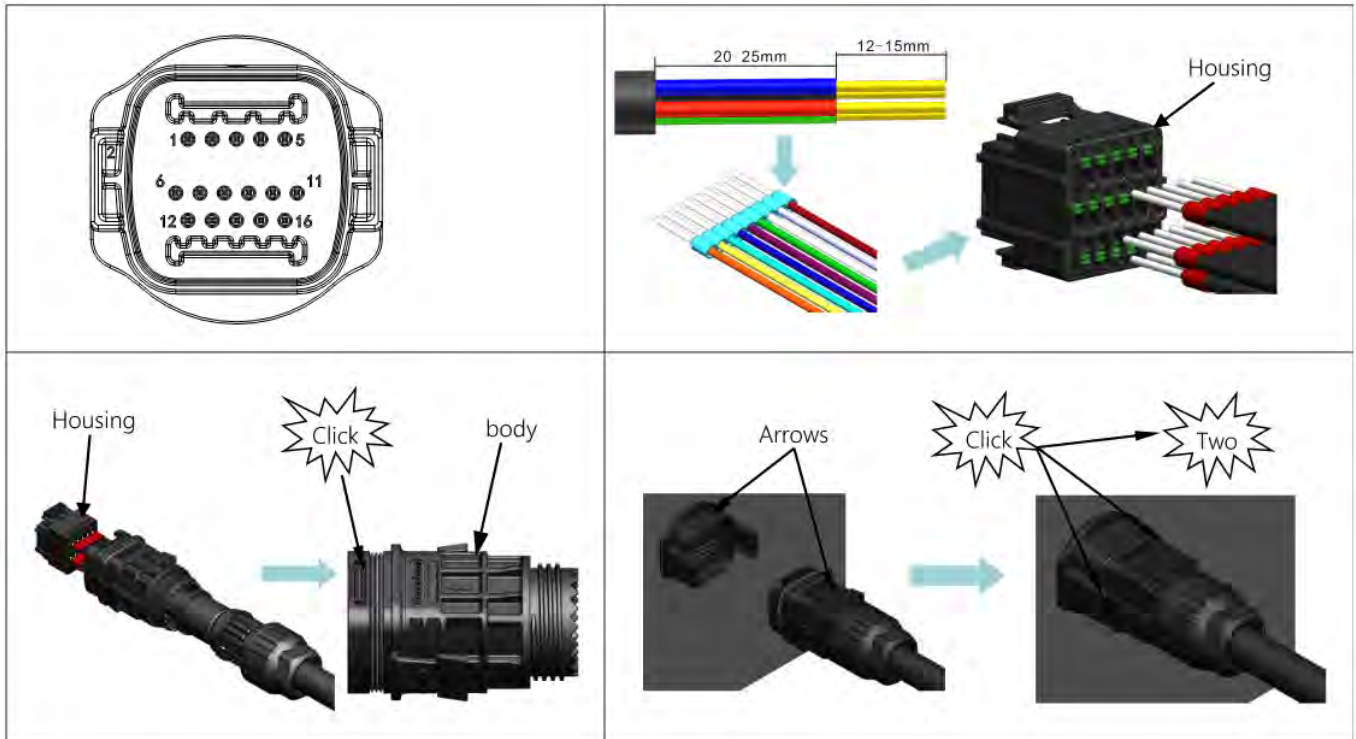
Name	Type	Outer diameter (mm)	Area (mm <sup>2</sup> )
RS485 Communication Wire	Outdoor shielded twisted pair meets local standards	3 core: 4~8	0.25~1

Port Description :

PIN	Define	Function	Note
1	RS485A	RS485 signal+	Wire connection monitoring or multiple inverter monitoring
2	RS485A	RS485 signal+	
3	RS485B	RS485 signal-	
4	RS485B	RS485 signal-	
5	Electric meter RS485A	Electric meter RS485 signal+	Wire connection Electric Meter
6	Electric meter RS485B	Electric meter RS485 signal-	
7	GND.S	RS485 signal ground	
8	DRM0	Remote shunt down	DRMS port
9	DRM1/5		
10	DRM2/6		
11	DRM3/7		
12	DRM4/8		
13	GND.S	Communication Ground	
14-16	Blank PIN	N/A	N/A



Procedure:



Procedure : (Corresponding to the second communication terminal)

## Communications Port Description

Logic interface

Logic interface for AS/NZS 4777.2:2020, also known as inverter demand response modes (DRMs).

The inverter will detect and initiate a response to all supported demand response commands within 2 s. The inverter will continue to respond while the mode remains asserted.

Pin NO.	Function
9	DRM1/5
10	DRM2/6
11	DRM3/7
12	DRM4/8
13	GND
8	DRM0

Function description of the DRMs terminal

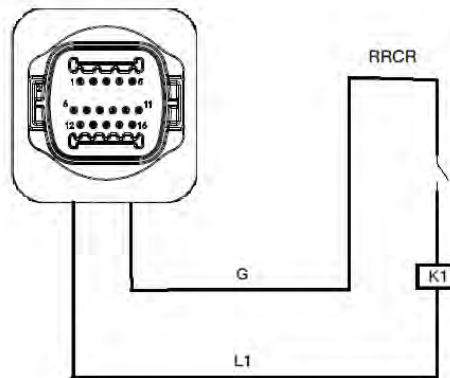
NOTE: Supported DRM command: DRM0, DRM5, DRM6, DRM7, DRM8.



Logic interface for EN50549-1:2019 and VDE-AR-N 4105:2018-11, is in order to cease active power output within five seconds following an instruction being received at the input interface.

Pin NO.	Function
9	DRM1/5
10	DRM2/6
11	DRM3/7
12	DRM4/8
13	GND
8	DRM0

Logic interface for EN50549-1:2019 and VDE-AR-N 4105:2018-11, is in order to cease active power output within five seconds following an instruction being received at the input interface.



**Inverter – RRCR Connection**

Pin NO.	Pin name	Description	Connected to (RRCR)
9	L1	Relay contact 1 input	K1 - Relay 1 output
13	G	GND	K1 - Relay 1 output

**Function description of the terminal**

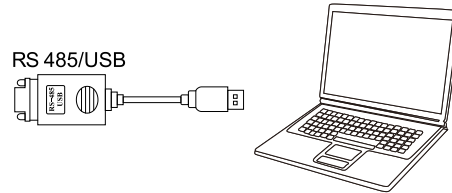
Relay status: close is 1, open is 0

L1	Active Power	Power drop rate	Cos(φ)
1	0%	<5 seconds	1
0	100%	/	1

The inverter is preconfigured to the following RRCR power levels.

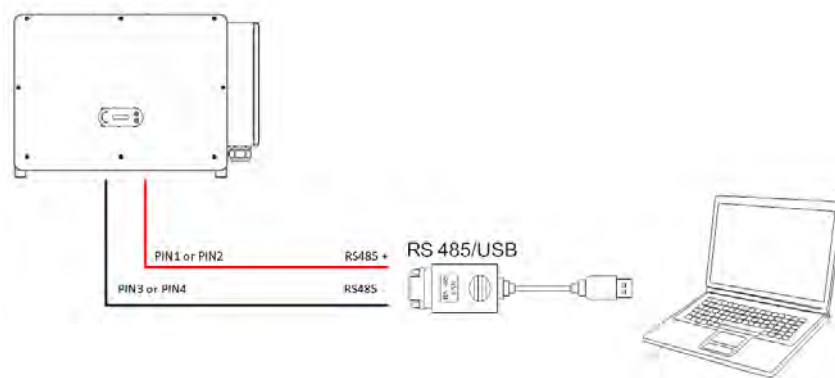
## RS485

By RS485 interface, transfer the inverter power output information, alarm information, operation state to the PC terminal or local data acquisition device, then uploaded to the server.



Picture of the RS485/USB converter and PC terminal

If only one ZCS AZZURRO 250/350KTL HV-Z0 is used, use a communication cable, refer to section for COM pin definition, and choose either of the two RS485 ports.



Single ZCS AZZURRO 250/350KTL-HV connecting communications



### Note

- The length of the RS485 communication cable should be less than 1000 m.
- The length of the WIFI communication cable should be less than 100 m.

## PBUS Communication (Multi inverter monitoring system)

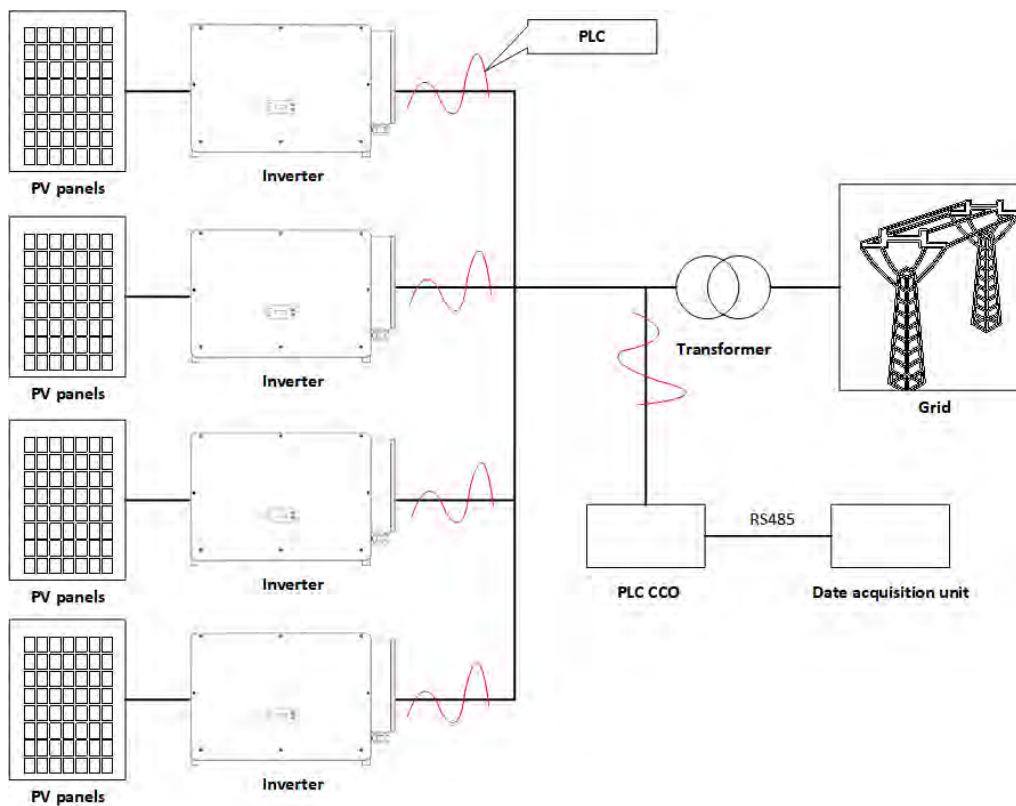



Figure 31 - 16 Multi inverter monitoring system

This configuration is under development for more information contact Zucchetti Centro Sistemi (pre-sales).

## 6. Commissioning the inverter


### 6.1. Safety inspection before commissioning

	<p><b>Before starting up the equipment for the first time (test run), all operations performed on the equipment should be thoroughly checked. In particular, check that the DC terminal voltage and the AC terminal voltage are in accordance with the range permitted by the inverter.</b></p>
<b>Attention</b>	

Before switching on the inverter for the first time, the following checks need to be done.

- **The AC switch connecting the inverter and all DC switches on the inverter are disconnected.**
- **Check that the inverter is mounted in place and is firm and reliable.**
- **Check that the earth wire is reliably connected and that the grounding resistance is less than 0.1Ω.**
- **Check that the AC cables and DC cables are wired correctly and that the various wiring must be firm and reliable.**
- **The AC circuit breaker is selected in accordance with the requirements of this manual and local standards.**
- **Check that the communication cables are connected correctly and reliably.**
- **Check that the vacant terminals have been sealed.**

## 6.2. Starting the inverter

 <b>Attention</b>	<p>DC switch has the function of automatic breaking, if the wiring has the phenomenon of string reverse connection, string overcurrent, etc., it will trigger the DC switch automatic breaking protection, please check the corresponding fault information in the Shouhang cloud monitoring APP, refer to the instructions in section 9.1 to check the alarm, and confirm that the alarm disappears before you close the DC switch.</p> <p>Do not allow any obstacles (e.g. cables or operators holding down the handle) within the rotational travel of the DC switch handle during system power-up or operation, otherwise the DC switch will not be able to break automatically.</p> <p>Do not close the DC switch when the grid connection indicator is green (the inverter is in grid connection), otherwise the inverter may be damaged due to lack of insulation impedance test.</p>
---	--

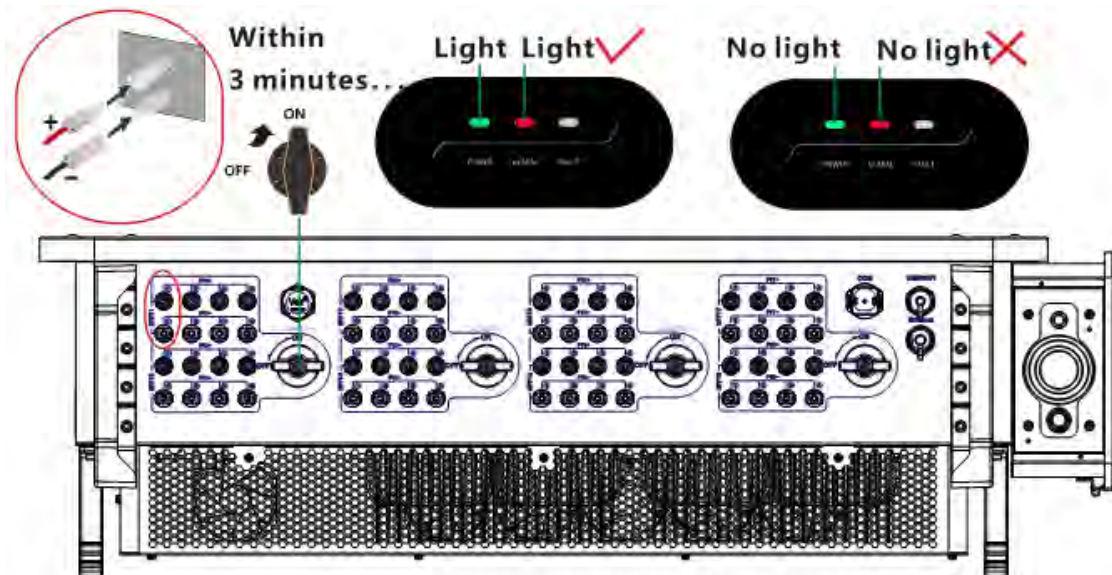
If all of the above items are in order, perform the following steps to start the inverter for the first time.

- 1) Wear PPE and disconnect all DC switches:

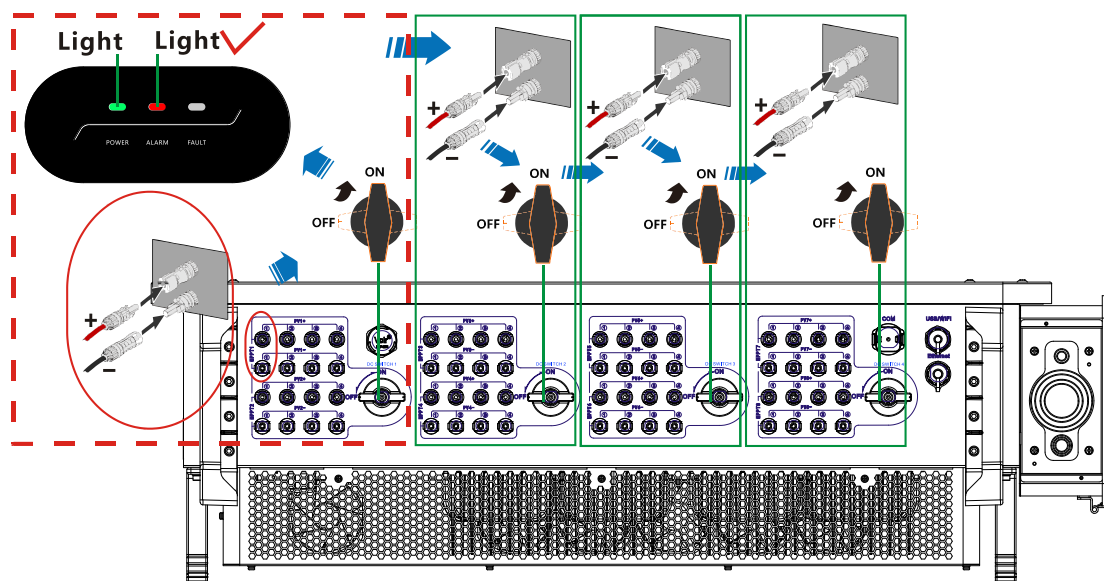




- 2) Measure the voltage of a group of strings with a multimeter and connect PV+ and PV- to the input of PV1 of the inverter respectively. Close the DC SWITCH1 switch, within 3 minutes, you can see the POWER lamp is always on, ALARM lamp is always on (not connected to AC), that means the first set of string PV+ and PV- access is correct. If you do not see the POWER lamp is always on/ALARM lamp is always on within 3 minutes, it means that the first set of string PV+ and PV- are connected incorrectly. Disconnect the DC SWITCH1 switch, re-exchange the PV+ and PV- access, and re-access the test according to the second step. If the POWER/ALARM light is not on for 3 minutes, please contact the technical support engineer.

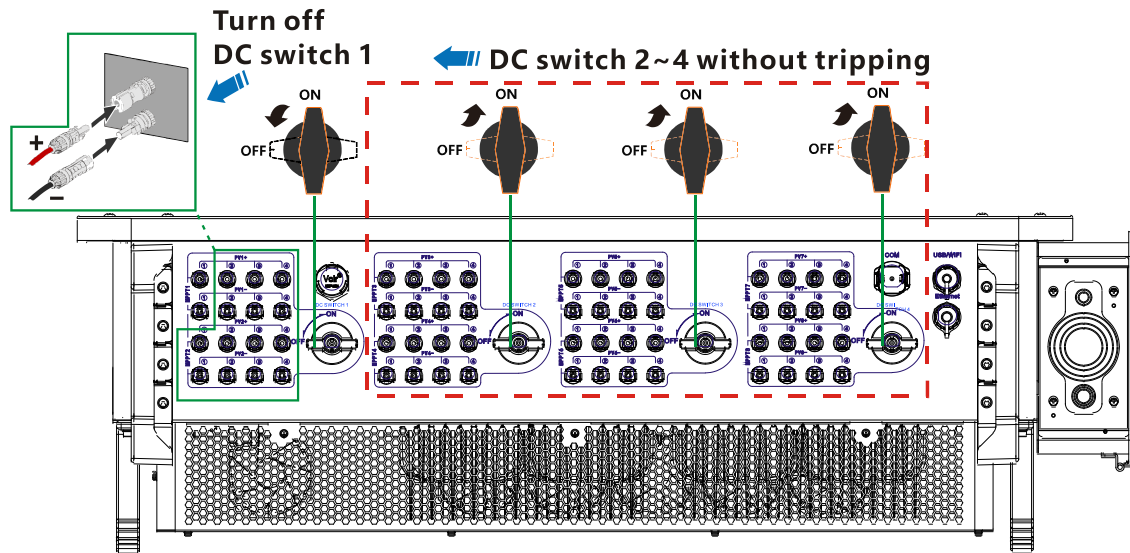


- 3) After the PV1 branch is correctly connected, light up the LED condition. After connecting the six-channel string of MPP3~MPPT8 to the PV input of the inverter according to PV+ and PV- correspondingly, close the three DC switches of DC SWITCH2/3/4. If there is no DC switch decoupling, it means that all the branches are connected correctly. If there is a DC switch debounce, it means that the DC switch corresponding to the PV branch has a reverse connection phenomenon, after re-checking the defective, correctly connected to the inverter, close the debounce DC switch.

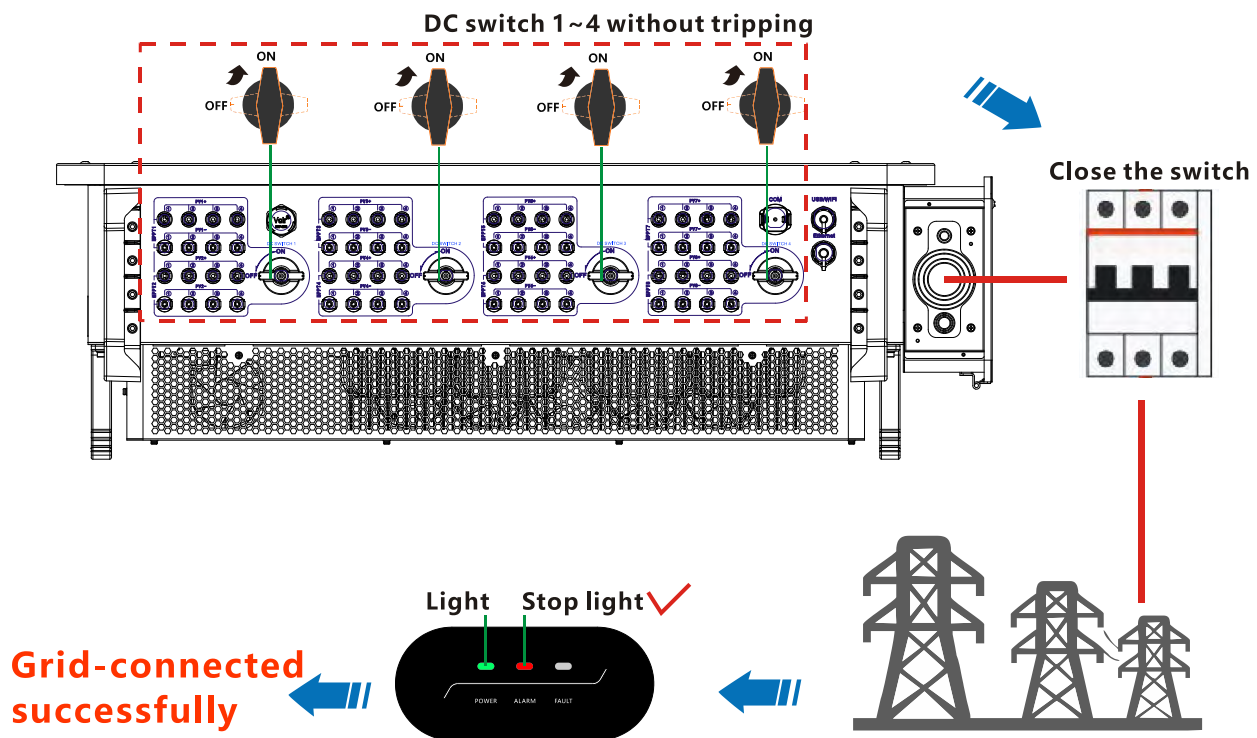




- 4) Disconnect the DC SWITCH1 switch, connect the remaining strings to the MPP1 and MPPT2 branches correctly, and close the DC SWITCH1 switch. If there is no DC switch release, it means that all strings are connected correctly. If there is a DC switch debounce, it means that the DC switch corresponding to the PV branch has a reverse connection phenomenon, after re-checking the defective, correctly connected to the inverter, close the debounce DC switch.



- 5) Close the switch between the inverter and the AC power grid. within 3 minutes the ALARM light is off and the POWER light is always on, the inverter is successfully connected to the grid. If the FAULT light is on or there are other defects, disconnect all switches and contact the technical support engineer in time. If the inverter is faulty, please refer to section of this manual for one by one troubleshooting.



6) Set the correct country code.

Note: Different grid operators in different countries require different specifications regarding the grid connections of PV inverters. Therefore, it is very important to select the correct country code according to the requirements of the local authorities.

If in doubt, consult the system engineer or a qualified electrician.

Zucchetti Centro Sistemi S.p.A. shall not be held responsible for any consequences resulting from the incorrect selection of the country code.

If the inverter indicates the presence of any faults, refer to related chapter of this manual or contact the Zucchetti Centro Sistemi S.p.A. technical support.

## 7. APP Azzurro Operators

### 7.1. Overview

Azzurro Operators is a new efficient, safe, fast and intelligent photovoltaic monitoring software, complete the near-end debugging and remote monitoring Settings. From the creation of power Plants to management, operation and maintenance, realize integrated services, easy to master your power Plant information. In the power Plant information, not only the monitored data information can be reflected through digital and dynamic flow diagrams, but also the real-time Alarm notification of faults, bringing you a simpler and more convenient experience.

### 7.2. Dowload

Mobile operating system requirements, minimum version Android 7.0; iOS 14.0.

1. ① Android phone users: search for "Azzurro Operators" in the Android app market (Snap Pea, Baidu, etc.), download and install.
2. ② You can also download " Azzurro Operators " by directly scanning the QR code below or taking a screenshot.



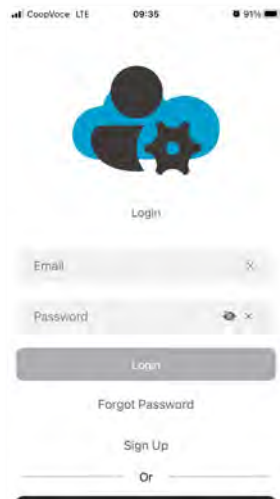
QR code

## 7.3. Account Registration and Login

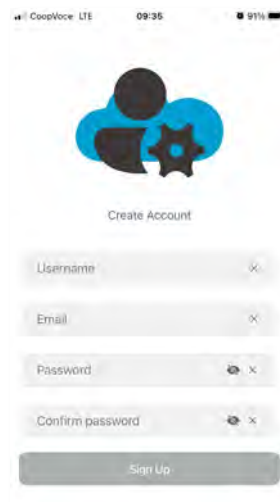
### 7.3.1. Registration

To access the Azure operators APP there are 2 ways:

1. If you already have a Azzurro System account or Azzurro Operators account you can log in using the usual Email and Password:



2. Otherwise to create a new account Azzurro Operators access the section "sing in":



3. Complete the registration by entering the required data:


- ✓ Username;
- ✓ Email;
- ✓ Password;
- ✓ Confirm Password.

After you complete the information correctly, click the "Sign Up" button to automatically log in to the account.

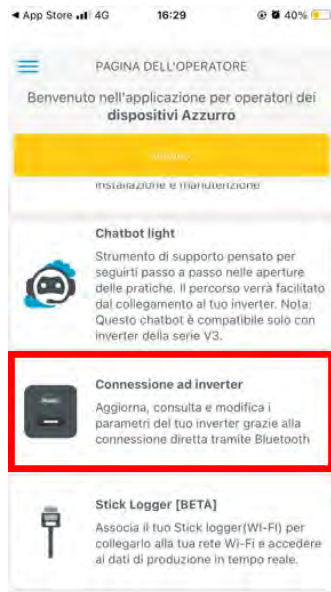
## 7.4. Local Control

Please turn on the Bluetooth of your mobile phone in advance before using this function.

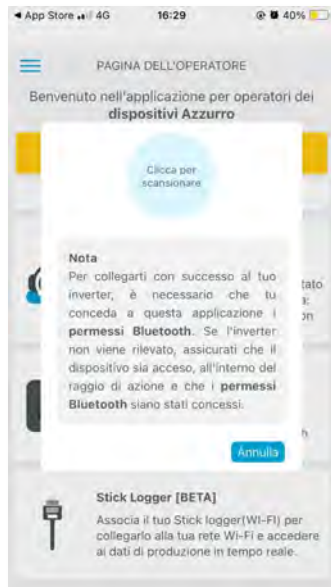
### 7.4.1. Bluetooth Connection

	<p><b>Always keep a distance of less than 1 meter from the device to ensure the correct Bluetooth connection.</b></p>
Attention	

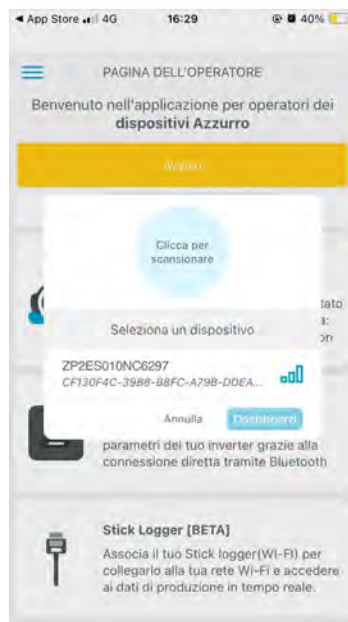
**Step 1:** Once enabled the Bluetooth in the smartphone access the section "connection to inverter".



**Step 2:** Press on the button "click to scan".



**Step 3:** After the scan will appear the serial of the inverter in your possession (see example photo below), click on the inverter serial o access the configuration:





## 7.4.2. Dashboard

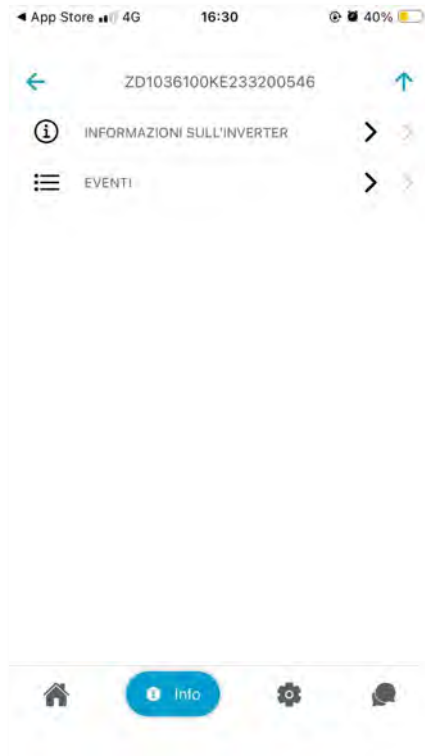
In the Dashboard section you can see the power flows and any current alarms.



### 7.4.3.Info

In the Info section you can see:

- ✓ Inverter Information - in this section you can see how the inverter is configured and set.
- ✓ Events - In this section you can see the current alarms and the alarm history.



## 7.4.4.Setting

In the Settings section you can see and modify all the inverter configuration and setting.



## 8. Operating interface

### General information in this chapter

This section describes the display and its operation, as well as the buttons and LED indicators of the 3PH 250KTL-350KTL inverters.

### 8.1. Operating panel and display

#### Buttons and LED indicators

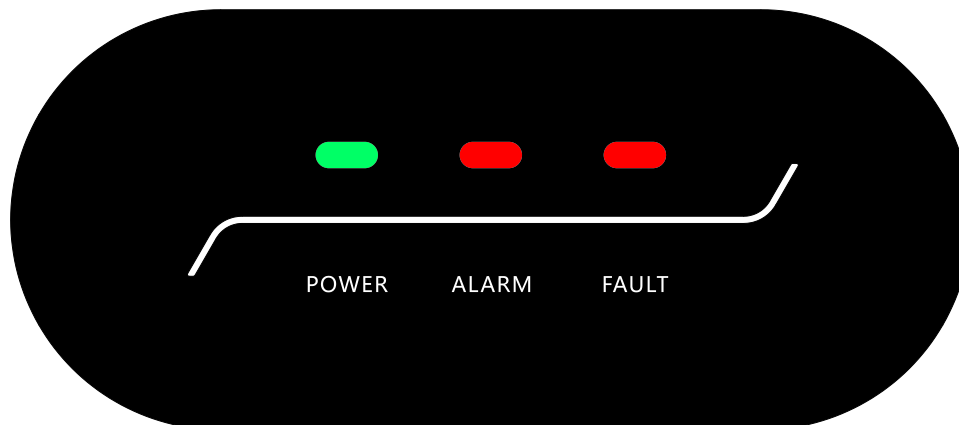


Figure 32 – LCD display with buttons and LED indicators

#### Indicator lights:

- Green light (POWER) on = Normal: Always on;
- In upgrading: fast flashing (on for 200ms/off for 200ms);
- In detection: slow flash (200ms on/ 1s off).
- Red (ALARM) = Recoverable fault or permanent fault status.
- Red (FAULT) on = GFCI leakage current fault or low insulation impedance alarm, LED on and buzzer sounding.

## 8.2. Updating Inverter Software

AZZURRO 3PH 250KTL-350KTL HV-Z0 inverter offer software upgrade via USB flash drive to maximize inverter performance and avoid inverter operation error caused by software bugs.

On first installation, all Zucchetti inverters must be updated to the latest firmware version found in the [www.zcsazzurro.com](http://www.zcsazzurro.com) website, unless the inverter is already updated to the version on the website or to a later version (see image below).

**Do not update the inverter if its firmware version is the same or higher than the one found in the ZCS Azzurro website**



**ATTENTION!!! Downgrading the firmware version of the inverter could lead to a malfunction.**

3PH 350KTL-350KTL HV-Z0 inverters must be upgraded using an 8 GB USB stick.

- 1) Turn off AC circuit breaker and DC switch, remove the communication board cover as below figure. If the RS485 line has been connected, please release the waterproof nut first and make sure the communication line is no longer the force. Then remove the waterproof cover.

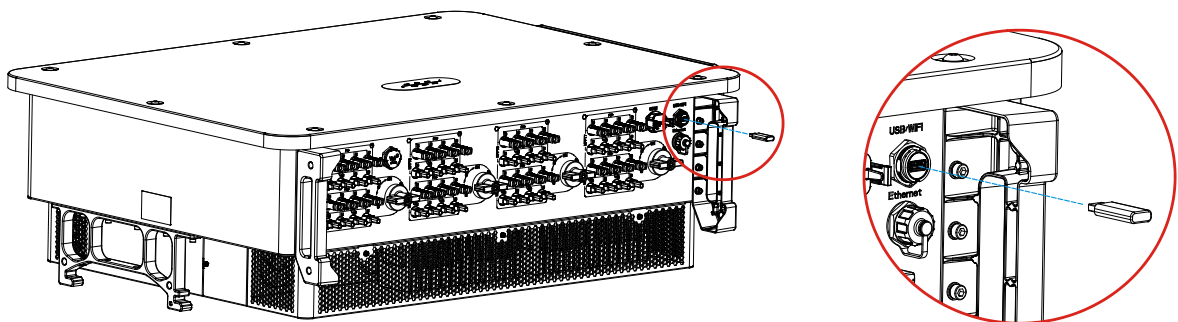


Figure 33 – Remove communication board cover

- 2) Insert the USB stick into the computer

- 3) Download the firmware of your inverter from the products section (storage inverters) of the [www.zcsazzurro.com](http://www.zcsazzurro.com) website, selecting the inverter model you own
- 4) Save only the firmware folder containing the .bin files on the USB stick.
- 5) Safely remove the USB stick from the computer
- 6) Make sure the inverter is switched off
- 7) Insert the USB stick in the appropriate USB port of the inverter
- 8) Switch on the inverter by turning the inverter's DC rotary switch to ON
- 9) Start the update

### 8.3. Safety Regulation Management

#### Safety details

Click "Safety details", you can view the current model of safety national, regional standards, version number and safety database version number information, can let you more clearly understand the current safety information of the machine.

#### Safety setting

The safety management screen is displayed. You can click Safety Settings to display the read and write safety parameters. You can set the parameters as required. Safety parameters can be set: Set power grid voltage protection parameters.



## 9. Troubleshooting and maintenance

### 9.1. Troubleshooting

This section describes the potential errors for this product. Please read carefully for the following tips when doing the troubleshooting:

- 1) Check the warning message or faulty codes on the inverter information panel.
- 2) If not any error code display on the panel, please check the following lists:
  - Is inverter be installed in a clean, dry, ventilated environment?
  - Is the DC switch turn off?
  - Are the cable cross section area and length meet the requirement?
  - Are the input and output connection and wiring in good condition?
  - Are the configuration settings correctly for the particular installation?

This section contains the potential errors, resolution steps, and provide users with troubleshooting methods and tips.

The process to check the event list can refers to Manual.

Code	Name	Description	Solution
<b>ID001</b>	GridOVP	The grid voltage is too high	If the alarm occurs occasionally, the possible cause is that the electric grid is abnormal occasionally. Inverter will automatically return to normal operating status when the electric grid's back to normal.
<b>ID002</b>	GridUVP	The grid voltage is too low	
<b>ID003</b>	GridOFP	The grid frequency is too high	
<b>ID004</b>	GridUFP	The grid frequency is too low	If the alarm occurs frequently, check whether the grid voltage/frequency is within the acceptable range. If yes, please check the AC circuit breaker and AC wiring of the inverter. If the grid voltage/frequency is NOT within the acceptable range and AC wiring is correct, but the alarm occurs repeatedly, contact technical support to change the grid over-voltage, under-voltage, over-frequency, under-frequency protection points after obtaining approval from the local electrical grid operator.
<b>ID005</b>	GFCI	Charge Leakage Fault	Check for inverter and wiring.
<b>ID006</b>	OVRT fault	OVRT function is faulty	If the alarm occurs occasionally, the possible cause is that the electric grid is abnormal occasionally. Inverter will automatically return to normal operating status when the
<b>ID007</b>	LVRT fault	LVRT function is faulty	

<b>ID008</b>	IslandFault	Island protection error	<p>electric grid's back to normal.            If the alarm occurs frequently, check whether the grid voltage/frequency is within the acceptable range. If yes, please check the AC circuit breaker and AC wiring of the inverter. If the grid voltage/frequency is NOT within the acceptable range and AC wiring is correct, but the alarm occurs repeatedly, contact technical support to change the grid over-voltage, under-voltage, over-frequency, under-frequency protection points after obtaining approval from the local electrical grid operator.</p>
<b>ID009</b>	GridOVPIstant1	Transient overvoltage of grid voltage 1	
<b>ID010</b>	GridOVPIstant2	Transient overvoltage of grid voltage 2	
<b>ID011</b>	VGridLineFault	Power grid line voltage error	
<b>ID013</b>	RefluxFault	Anti-Reflux function is faulty	
<b>ID017</b>	HwADFaultIGrid	Power grid current sampling error	
<b>ID018</b>	HwADFaultDCI	Wrong sampling of dc component of grid current	
<b>ID019</b>	HwADFaultVGrid(DC)	Power grid voltage sampling error (DC)	
<b>ID020</b>	HwADFaultVGrid(AC)	Power grid voltage sampling error (AC)	
<b>ID021</b>	GFCIDeviceFault(DC)	Leakage current sampling error(DC)	
<b>ID022</b>	GFCIDeviceFault(AC)	Leakage current sampling error(AC)	
<b>ID023</b>	HwADFaultDCV	Load voltage DC component sampling error	
<b>ID024</b>	HwADFaultIdc	Dc input current sampling error	
<b>ID025</b>	HwADErrDCI(DC)	DCI Sampling Error (DC)	
<b>ID026</b>	HwADErrIdcBranch	\	
<b>ID027</b>	PVLowImpedance	PV- Low impedance to PE	
<b>ID028</b>	PIDAbnormalOut	PID Abnormal Output	
<b>ID029</b>	ConsistentFault_GFCI	Leakage current consistency error	
<b>ID030</b>	ConsistentFault_Vgrid	Grid voltage consistency error	
<b>ID031</b>	ConsistentDCI	DCI consistency error	
<b>ID033</b>	SpiCommFault(DC)	SPI communication error (DC)	
<b>ID034</b>	SpiCommFault(AC)	SPI communication error (AC)	
<b>ID035</b>	SChip_Fault	Chip error (DC)	
<b>ID036</b>	MChip_Fault	Chip error (AC)	
<b>ID037</b>	HwAuxPowerFault	Auxiliary power error	
<b>ID038</b>	InvSoftStartFail	Inverter soft startup failed	

<b>ID039</b>	ArcShutdownAlarm	Arc shutdown protection	
<b>ID040</b>	LowLightChkFail	Low light detection failure	
<b>ID041</b>	RelayFail	Relay detection failure	
<b>ID042</b>	IsoFault	Low insulation impedance	Check the insulation resistance between the photovoltaic array and ground (ground), if there is a short circuit, the fault should be repaired in time.
<b>ID043</b>	PEConnectFault	Ground fault	Check ac output PE wire for grounding.
<b>ID044</b>	ConfigError	Error setting input mode	Check the input mode (parallel/independent mode) Settings for the inverter. If not, change the input mode.
<b>ID045</b>	CTDisconnect	CT error	
<b>ID046</b>	ReversalConnection	Input Reverse Error	
<b>ID047</b>	ParallelFault	Parallelization error	
<b>ID050</b>	TempFault_HeatSink1	Radiator temperature protection 1	
<b>ID051</b>	TempFault_HeatSink2	Radiator temperature protection 2	
<b>ID052</b>	TempFault_HeatSink3	Radiator temperature protection 3	
<b>ID053</b>	TempFault_HeatSink4	Radiator temperature protection 4	
<b>ID054</b>	TempFault_HeatSink5	Radiator temperature protection 5	
<b>ID055</b>	TempFault_HeatSink6	Radiator temperature protection 6	
<b>ID056</b>	TempDiffErrInv	Temperature difference error of inverter module	
<b>ID057</b>	TempFault_Env1	Ambient temperature 1 protection	
<b>ID058</b>	TempFault_Env2	Ambient temperature 2 protection	
<b>ID059</b>	TempFault_Inv1	Module 1 temperature protection	
<b>ID060</b>	TempFault_Inv2	Module 2 temperature protection	
<b>ID061</b>	TempFault_Inv3	Module 3 temperature protection	
<b>ID062</b>	TempFault_Inv4	Module 4 temperature protection	
<b>ID063</b>	TempFault_Inv5	Module 5 temperature	

		protection	
<b>ID064</b>	TempFault_Inv6	Module 6 temperature protection	
<b>ID065</b>	VbusRmsUnbalance	Unbalanced bus voltage RMS	<p>Internal faults of inverter, switch OFF inverter, wait for 5 minutes, then switch ON inverter. Check whether the problem is solved.</p> <p>If no, please contact technical support.</p>
<b>ID066</b>	VbusInstantUnbalance	The transient value of bus voltage is unbalanced	
<b>ID067</b>	BusUVP	Busbar undervoltage during grid-connection	
<b>ID068</b>	BusZVP	Bus voltage low	
<b>ID069</b>	PVOVP	PV over-voltage	<p>Check whether the PV series voltage (Voc) is higher than the maximum input voltage of the inverter. If so, adjust the number of PV modules in series and reduce the PV series voltage to fit the input voltage range of the inverter. After correction, the inverter will automatically return to its normal state.</p>
<b>ID072</b>	SwBusRmsOVP	Inverter bus voltage RMS software overvoltage	
<b>ID073</b>	SwBusInstantOVP	Inverter bus voltage instantaneous value software overvoltage	
<b>ID074</b>	FlyingCapOVP		
<b>ID075</b>	FlyingCapUVP		
<b>ID076</b>	PVUVP	PV undervoltage protection	
<b>ID082</b>	DciOCP	Dci overcurrent protection	
<b>ID083</b>	SwOCPIstant	Output instantaneous current protection	
<b>ID084</b>	SwBuckBoostOCP	BuckBoost software overcurrent protection	
<b>ID085</b>	SwAcRmsOCP	Output effective value current protection	
<b>ID086</b>	SwPvOCPIstant	PV overcurrent software protection	
<b>ID087</b>	IpvUnbalance	PV flows in uneven parallel	
<b>ID088</b>	IacUnbalance	Unbalanced output current	
<b>ID089</b>	SwPvOCP	PV overcurrent software protection	
<b>ID090</b>	IbalanceOCP	Inverter bus balance current protection	
<b>ID091</b>	SwAcCBCFault	Software AC Over Current Protection	

<b>ID092</b>	SwAcCBCFault	Software current limited protection	
<b>ID093</b>	SwPvBranchOCP	PV branch over current protection	
<b>ID098</b>	HwBusOVP	Inverter bus hardware overvoltage	
<b>ID099</b>	HwBuckBoostOCP	BuckBoosthardware overflows	
<b>ID102</b>	HwPVOCP	PV hardware overflows	
<b>ID103</b>	HwACOCP	Ac output hardware overflows	
<b>ID105</b>	MeterCommFault	Meters communication fault	Check whether the meters wiring is correct.
<b>ID106</b>	SNMachineFault	Serial number machine error	
<b>ID107</b>	HwVerError	Hardware version mismatch	
<b>ID110</b>	Overload1	Overload protection 1	Please check whether the inverter is operating under overload.
<b>ID111</b>	Overload2	Overload protection 1	
<b>ID112</b>	Overload3	Overload protection 1	
<b>ID113</b>	OverTempDerating	Internal temperature is too high.	Make sure the inverter is installed where there is no direct sunlight. Please ensure that the inverter is installed in a cool/well ventilated place. Ensure the inverter is installed vertically and the ambient temperature is below the inverter temperature limit.
<b>ID114</b>	FreqDerating	AC frequency is too high	Please make sure the grid frequency and voltage is within the acceptable range.
<b>ID115</b>	FreqLoading	AC frequency is too low	
<b>ID116</b>	VoltDerating	AC voltage is too high	
<b>ID117</b>	VoltLoading	AC voltage is too low	
<b>ID129</b>	PermHwAcOCP	Permanent hardware overcurrent failure	Internal faults of inverter, switch OFF inverter, wait for 5 minutes, then switch ON inverter. Check whether the problem is solved.  If no, please contact technical support.
<b>ID130</b>	PermBusOVP	Permanent Bus overvoltage failure	
<b>ID131</b>	PermHwBusOVP	Permanent Bus hardware overvoltage failure	
<b>ID132</b>	PermIpvUnbalance	Permanent PV unbalance failure	
<b>ID134</b>	PermAcOCPIinstant	Output transient overcurrent permanent failure	
<b>ID135</b>	PermIacUnbalance	Permanent failure of unbalanced output current	
<b>ID136</b>	PermInvStartFail	Permanent INV start	

		failure	
<b>ID137</b>	PermInCfgError	Input mode setting error permanent failure	
<b>ID138</b>	PermDCOCPIInstant	Input overcurrent permanent fault	
<b>ID139</b>	PermHwDCOCP	Input hardware overcurrent permanent failure	
<b>ID140</b>	PermRelayFail	Permanent relay failure	
<b>ID141</b>	PermBusUnbalance	Bus voltage unbalanced permanent failure	
<b>ID142</b>	PermSpdFail(DC)	PV surge protection	
<b>ID143</b>	PermSpdFail(AC)	Grid surge protection	
<b>ID162</b>	RemoteShutdown	Remote shutdown	The inverter is performed a remote shutdown.
<b>ID163</b>	Drms0Shutdown	Drms0 shutdown	The inverter is performed with a Drms0 shutdown.
<b>ID164</b>	PSCommFault	Power station communication failure	
<b>ID169</b>	FanFault1	Fan 1 fault	Please check whether the fan 1 of inverter is running normally.
<b>ID170</b>	FanFault2	Fan 2 fault	Please check whether the fan 2 of inverter is running normally.
<b>ID171</b>	FanFault3	Fan 3 fault	Please check whether the fan 3 of inverter is running normally.
<b>ID172</b>	FanFault4	Fan 4 fault	Please check whether the fan 4 of inverter is running normally.
<b>ID173</b>	FanFault5	Fan 5 fault	Please check whether the fan 5 of inverter is running normally.
<b>ID174</b>	FanFault6	Fan 6 fault	Please check whether the fan 6 of inverter is running normally.
<b>ID175</b>	FanFault7	Fan 7 fault	Please check whether the fan 7 of inverter is running normally.
<b>ID176</b>	FanFault8	Fan 8 fault	
<b>ID241</b>	USBFault	USB fault	
<b>ID242</b>	BluetoothFault	Bluetooth fault	
<b>ID243</b>	RTCFault	RTC Clock fault	
<b>ID244</b>	PIDFault	PID fault	
<b>ID257</b>	MDSPCommFault	Main DSP communication fault	
<b>ID258</b>	SDSPCommFault	Sub-DSP communication fault	
<b>ID259</b>	AFCI1CommFault	AFCI1 communication fault	
<b>ID260</b>	AFCI2CommFault	AFCI2 communication fault	



<b>ID273</b>	SafetyVerFault	Safety version error	
<b>ID274</b>	ARM_DSPProVerFault	ARM_DSP protocol version inconsistency	
<b>ID275</b>	ARM_AFCIProVerFault	ARM_AFCI protocol version inconsistency	
<b>ID276</b>	ARM_DCDCProVerFault	ARM_DCDC protocol version inconsistency	
<b>ID321</b>	AFCI1_ArcWarning_Ch1	PV1 DC arc trouble	
<b>ID322</b>	AFCI1_ArcWarning_Ch2	PV2 DC arc trouble	
<b>ID323</b>	AFCI1_ArcWarning_Ch3	PV3 DC arc trouble	
<b>ID324</b>	AFCI1_ArcWarning_Ch4	PV4 DC arc trouble	
<b>ID337</b>	AFCI2_ArcWarning_Ch1	PV5 DC arc trouble	
<b>ID338</b>	AFCI2_ArcWarning_Ch2	PV6 DC arc trouble	
<b>ID339</b>	AFCI2_ArcWarning_Ch3	PV7 DC arc trouble	
<b>ID340</b>	AFCI2_ArcWarning_Ch4	PV8 DC arc trouble	

## 9.2. Maintenance

Inverters generally do not need any daily or routine maintenance. But ensure heat sink should not be blocked by dust, dirt or any other items. Before the cleaning, make sure that the DC SWITCH is turned OFF and the circuit breaker between inverter and electrical grid is turned OFF. Wait at least for 5 minutes before the Cleaning.

### Cleaning the inverter

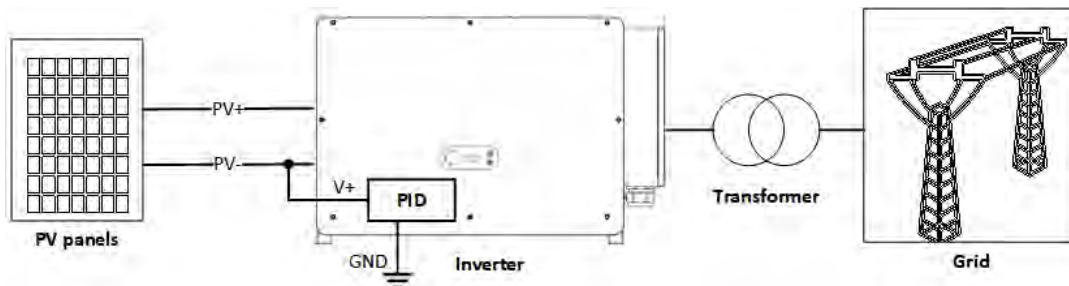
Please clean the inverter with an air blower, a dry & soft cloth or a soft bristle brush. Do not clean the inverter with water, corrosive chemicals, detergent, etc.

### Cleaning the heatsink

For the long-term proper operation of inverters, ensure there is enough space around the heat sink for ventilation, check the heat sink for blockage (dust, snow, etc.) and clean them if they exist. Please clean the heat sink with an air blower, a dry & soft cloth or a soft bristle brush. Do not clean the heat sink with water, corrosive chemicals, detergent, etc.

### 9.3. Maintenance

When the inverter is running, the PID function module increases the potential between the negative pole of the photovoltaic array and the ground to a positive value to suppress the PID effect.



#### Note

1. Before enabling the PID recovery function, ensure that the polarity of the pv module's ground voltage meets requirements. If in doubt, please contact the pv module manufacturer or read their corresponding user manual.
2. If the voltage scheme of the PID protection/recovery function does not meet the requirements of the corresponding PV module, the PID function cannot work properly or may even damage the PV module.
3. Before enabling the reverse PID function, ensure that the inverter has been applied to the IT system.
4. When the inverter is not running, the PID module will apply reverse voltage to the photovoltaic module to restore the degraded module.
5. If the PID recovery function is enabled, the PID works only at night. (Default PID repair time: 0:00-4:00).
6. After the PID recovery function is enabled, the PV series voltage to ground is 800Vdc by default. You can change the default value through the App.

### 9.4. SVG

After the SVG is enabled, the inverter can continue to be connected to the grid at night, and can respond to the reactive power scheduling instructions, saving the investment cost of the reactive static compensator.

1. It is necessary to turn on the SVG enable bit when PV is powered. If SVG is enabled at night, the inverter cannot start the grid connection at night. If you have any questions, please contact the photovoltaic module manufacturer or read its corresponding user manual.
2. When the inverter operates in SVG state, the LED display green light (POWER) is always on.
3. In SVG state, the maximum reactive power of the inverter is 30% of the maximum apparent power.
4. SVG only works at night. If PV is powered, the inverter will automatically switch to the "grid connected state".

## 10. Uninstalling

### 10.1. Uninstallation steps

- Disconnect the inverter from the AC grid by opening the AC circuit breaker.
- Disconnect the inverter from the photovoltaic strings by opening the DC circuit breaker.
- Wait 25 minutes.
- Remove the DC connectors.
- Remove the AC terminals.
- Unscrew the fixing bolt of the bracket and remove the inverter from the wall.

### 10.2. Packaging

If possible, pack the product in its original packaging.

### 10.3. Storage

Store the inverter in a dry place where the ambient temperature is between -30 and +60°C.

### 10.4. Disposal

Zucchetti Centro Sistemi S.p.A. is not liable for the disposal of the equipment, or parts thereof, that does not take place according to the regulations and standards in force in the country of installation.



The symbol of the crossed-out wheeled bin indicates that the equipment, at the end of its useful life, must be disposed of separately from household waste.

This product must be handed over to the waste collection point in your local community for recycling.

For more information, please contact the waste collection authority in your country.

Inappropriate waste disposal could have negative effects on the environment and on human health due to potentially hazardous substances.

With your cooperation in the correct disposal of this product, you contribute to the reuse, recycling and recovery of the product, and to the protection of our environment.





















## 11. Technical data 3PH 250-350KTL HV-Z0

TECHNICAL DATA	3PH 250KTL-HV-Z0	3PH 330KTL-HV-Z0	3PH 350KTL-HV-Z0
<b>DC Input data</b>			
Typical DC power*	300000W	396000W	420000W
Maximum DC power for each MPPT		51000W	
No. of independent MPPTs / No. of strings per MPPT	6/2	8/2	8/2
Maximum DC input voltage		1500V	
Start-up voltage		550V	
Nominal DC input voltage		1160V	
MPPT DC voltage range		500V-1500V	
DC voltage range at full load		860V-1300V	
Maximum input current for each MPPT		60A	
Maximum absolute current for each MPPT		100 A	
<b>AC Output data</b>			
Rated AC power	250kW	330kW	352kW
Maximum AC power	250kVA	330kVA	352kVA
Maximum AC current per phase	180.5A	238.2A	254.1A
Connection type/Rated grid voltage	three phase 3PH/PE 800V (PH-PH)		
Grid voltage range	370V~530V (PH-N); 640V~920V (PH-PH) (according to the local grid standards)		
Rated grid frequency	50Hz/60Hz		
Grid frequency range	45Hz~55Hz / 54Hz~66Hz (according to the local grid standards)		
Total harmonic distortion	<3%		
Power factor	1 (Programmable +/-0.8)		
Active power adjustment range (settable)	0~100%		
Grid feed-in limit	Feed-in adjustable from zero to nominal power value**		
<b>Efficiency</b>			
Maximum efficiency		99.05%	
Weighted efficiency (EURO)		98.8%	
MPPT efficiency		>99.9%	
Consumption at night		<1W	
<b>Protections</b>			
Internal interface protection		No	
Safety protections		Anti islanding, ROMU, Ground Fault Monitoring	
Reverse polarity protection DC		Yes	
DC circuit breaker		Integrated	
Overheating protection		Yes	
Overvoltage category/Protection class		Overvoltage category AC III / PV II / Protection class I	
Integrated dischargers		AC/DC: Type 2 standard	
<b>Standard</b>			
EMC		EN 61000-6-2/4,	
Safety standard		IEC 62109-1/2, IEC62116, IEC61727, IEC61683, IEC60068(1,2,14,30)	
Grid connection standard		Connection certificates and standards available on <a href="http://www.zcsazzurro.com">www.zcsazzurro.com</a>	
<b>Communication</b>			
Communication interface (optional)		Wi-Fi/4G/Ethernet (optional), RS485 (proprietary protocol), USB, Bluetooth	
<b>General data</b>			
Allowable ambient temperature range		-30°C...+60°C (power limit above 45°C)	
Topology		Transformerless	
Environmental protection class		IP66	
Allowable relative humidity range		0%.....100%	
Maximum operating altitude		4000m (ower limit above 4000m)	
Weight		< 60dB @ 1mt	
Noise level	111kg	113kg	113kg
Cooling		Forced fan convection	
Dimensions (H x L x D)		828mm*1159mm *366 mm	
Data monitoring		Led & Bluetooth + APP	
Warranty		10 years	

\* The typical DC power does not represent a maximum applicable power limit. The online configurator available at [www.zcsazzurro.com](http://www.zcsazzurro.com) will provide any applicable configurations.

\*\* Possible by using a specific meter

## 12. Monitoring systems

ZCS monitoring				
Product code	Product photo	APP monitoring	Portal monitoring	Possibility to send commands and to update the inverter remotely in case of technical support
ZSM-WIFI				
ZSM-ETH				
ZSM-4G				
Datalogger 4-10 Inverters				
Datalogger up to 31 Inverters				

### 12.1. External Wi-Fi adapter

#### 12.1.1. Installation

Unlike the internal Wi-Fi card, the external adapter must be installed for all compatible inverters. However, the procedure is quicker and easier as there is no need to open the front cover of the inverter.

In order to monitor the inverter, the RS485 communication address must be set to 01 directly from the display.



**Installation tools:**

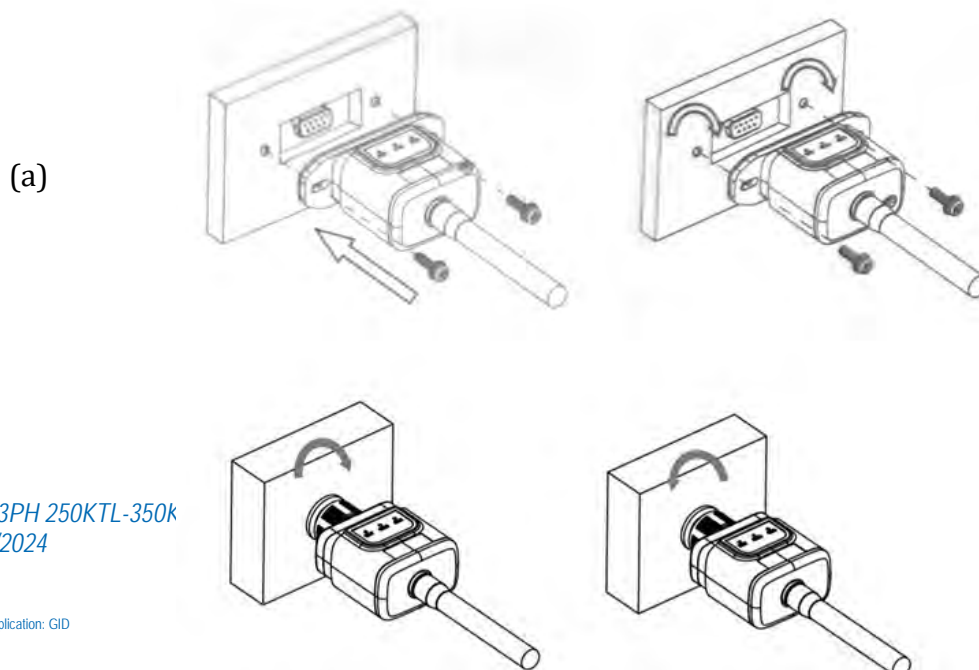
- Cross screwdriver
- External Wi-Fi adapter

- 1) Switch off the inverter following the procedure described in this manual.
- 2) Remove the cover for accessing the Wi-Fi connector on the bottom of the inverter by unscrewing the two cross-head screws (a), or by unscrewing the cover (b), as shown in the figure.



Figure 34 – Port for external Wi-Fi adapter

- 3) Connect the Wi-Fi adapter to the appropriate port, making sure to follow the direction of the connection and ensure correct contact between the two parts.





(b)

Figure 35 – Inserting and securing the external Wi-Fi adapter

4) Switch on the inverter by following the procedure described in the manual.

### 12.1.2. Configuration

Configuration of the Wi-Fi adapter requires the presence of a Wi-Fi network near the inverter in order to achieve stable transmission of data from the inverter adapter to the Wi-Fi modem.

**Tools required for configuration:**

- Smartphone, PC or tablet

Go to front of the inverter and search for the Wi-Fi network using a smartphone, PC or tablet, making sure that the signal from the home Wi-Fi network reaches the place where the inverter is installed.

If the Wi-Fi signal is present at the location where the inverter is installed, the configuration procedure can begin.

If the Wi-Fi signal does not reach the inverter, a system must be installed to amplify the signal and bring it to the installation location.

1) Activate the search for the Wi-Fi networks on your telephone or PC so that all the networks visible by your device are displayed.



Figure 36 – Search for Wi-Fi networks on iOS smartphone (left) and Android smartphone (right)

Note: Disconnect from any Wi-Fi networks to which you are connected by removing automatic access.



Figure 37 – Disabling automatic reconnection to a network

- 2) Connect to a Wi-Fi network generated by the inverter's Wi-Fi adapter (i.e. AP\_\*\*\*\*\*, where \*\*\*\*\* indicates the serial number of the Wi-Fi adapter shown on the label of the device), which operates as an access point.

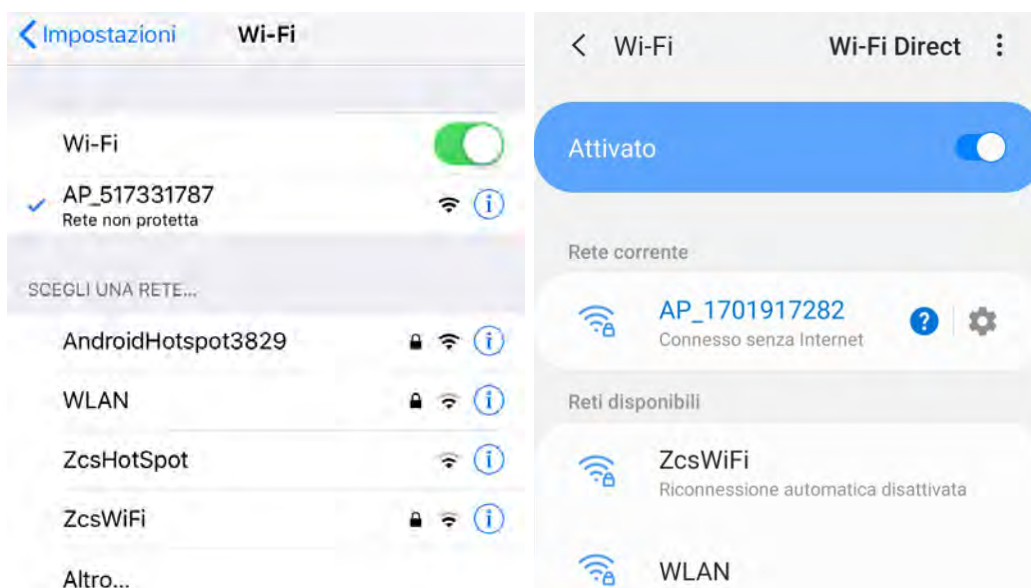


Figure 38 – Connection to Access Point for Wi-Fi adapter on iOS smartphone (left) and Android smartphone (right)

- 3) If you are using a second-generation Wi-Fi adapter, you will be prompted for a password to connect to the inverter's Wi-Fi network. Use the password found on the box or on the Wi-Fi adapter.



Figure 39 – Password of external Wi-Fi adapter

Note: To ensure that the adapter is connected to the PC or smartphone during the configuration procedure, enable automatic reconnection of the AP\_\*\*\*\*\* network.

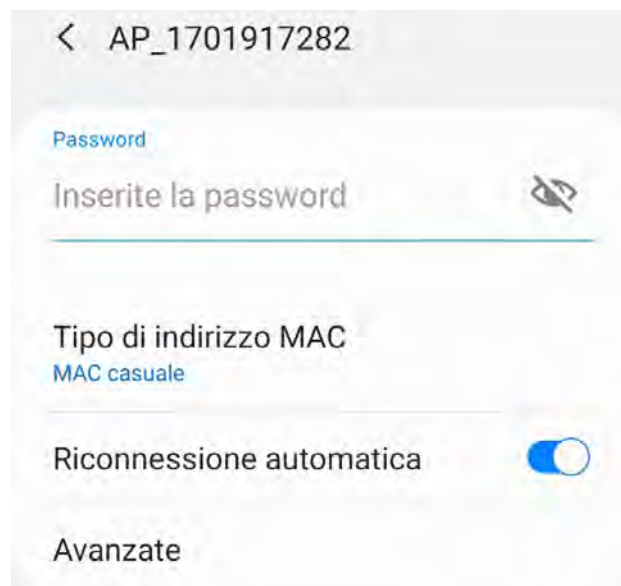


Figure 40 – Password entry prompt

Note: the Access Point is not able to provide internet access; confirm to maintain the Wi-Fi connection, even if the internet is not available





Figure 41 – Screen indicating that the Internet cannot be accessed

- 4) Open a browser (Google Chrome, Safari, Firefox) and enter the IP address 10.10.100.254 in the address bar at the top of the screen.  
In the box that appears, enter “admin” as both the Username and Password.



Figure 42 – Screen for accessing the web server to configure the Wi-Fi adapter

- 5) The status screen will open, showing the logger information such as the serial number and firmware version.

Check that the Inverter Information fields are filled in with the inverter information.

The language of the page can be changed using the command in the top right-hand corner.

中文 | English

<b>Status</b>	<p><b>- Inverter information</b></p> <table border="1"> <tr><td>Inverter serial number</td><td>ZH1ES160J3E488</td></tr> <tr><td>Firmware version (main)</td><td>V210</td></tr> <tr><td>Firmware version (slave)</td><td>---</td></tr> <tr><td>Inverter model</td><td>ZH1ES160</td></tr> <tr><td>Rated power</td><td>--- W</td></tr> <tr><td>Current power</td><td>--- W</td></tr> <tr><td>Yield today</td><td>11.2 kWh</td></tr> <tr><td>Total yield</td><td>9696.0 kWh</td></tr> <tr><td>Alerts</td><td>F12F14</td></tr> <tr><td>Last updated</td><td>0</td></tr> </table> <p><b>- Device information</b></p> <table border="1"> <tr><td>Device serial number</td><td>1701917282</td></tr> <tr><td>Firmware version</td><td>LSW3_14_FFFF_1.0.00</td></tr> <tr><td>Wireless AP mode</td><td>Enable</td></tr> <tr><td>SSID</td><td>AP_1701917282</td></tr> <tr><td>IP address</td><td>10.10.100.254</td></tr> <tr><td>MAC address</td><td>98:d8:63:54:0a:87</td></tr> <tr><td>Wireless STA mode</td><td>Enable</td></tr> <tr><td>Router SSID</td><td>AP_SOLAR_PORTAL_M2M_20120615</td></tr> <tr><td>Signal Quality</td><td>0%</td></tr> <tr><td>IP address</td><td>0.0.0.0</td></tr> <tr><td>MAC address</td><td>98:d8:63:54:0a:86</td></tr> </table> <p><b>- Remote server information</b></p> <table border="1"> <tr><td>Remote server A</td><td>Not connected</td></tr> <tr><td>Remote server B</td><td>Not connected</td></tr> </table>	Inverter serial number	ZH1ES160J3E488	Firmware version (main)	V210	Firmware version (slave)	---	Inverter model	ZH1ES160	Rated power	--- W	Current power	--- W	Yield today	11.2 kWh	Total yield	9696.0 kWh	Alerts	F12F14	Last updated	0	Device serial number	1701917282	Firmware version	LSW3_14_FFFF_1.0.00	Wireless AP mode	Enable	SSID	AP_1701917282	IP address	10.10.100.254	MAC address	98:d8:63:54:0a:87	Wireless STA mode	Enable	Router SSID	AP_SOLAR_PORTAL_M2M_20120615	Signal Quality	0%	IP address	0.0.0.0	MAC address	98:d8:63:54:0a:86	Remote server A	Not connected	Remote server B	Not connected	<b>Help</b>
Inverter serial number	ZH1ES160J3E488																																															
Firmware version (main)	V210																																															
Firmware version (slave)	---																																															
Inverter model	ZH1ES160																																															
Rated power	--- W																																															
Current power	--- W																																															
Yield today	11.2 kWh																																															
Total yield	9696.0 kWh																																															
Alerts	F12F14																																															
Last updated	0																																															
Device serial number	1701917282																																															
Firmware version	LSW3_14_FFFF_1.0.00																																															
Wireless AP mode	Enable																																															
SSID	AP_1701917282																																															
IP address	10.10.100.254																																															
MAC address	98:d8:63:54:0a:87																																															
Wireless STA mode	Enable																																															
Router SSID	AP_SOLAR_PORTAL_M2M_20120615																																															
Signal Quality	0%																																															
IP address	0.0.0.0																																															
MAC address	98:d8:63:54:0a:86																																															
Remote server A	Not connected																																															
Remote server B	Not connected																																															

The device can be used as a wireless access point (AP mode) to facilitate users to configure the device, or it can also be used as a wireless information terminal (STA mode) to connect the remote server via wireless router.

**Status of remote server**

◆ Not connected: Connection to server failed last time.  
If under such status, please check the issues as follows:  
(1) check the device information to see whether IP address is obtained or not;  
(2) check if the router is connected to internet or not;  
(3) check if a fire-wall is set on the router or not;

◆ Connected: Connection to server successful last time.

◆ Unknown: No connection to server. Please check again in 5 minutes.

Figure 43 – Status screen

- 6) Click on the Wizard setup button in the left-hand column.
- 7) In the new screen that opens, select the Wi-Fi network to which you want to connect the Wi-Fi adapter, making sure that the Received Signal Strength Indicator (RSSI) is greater than 30%. If the network is not visible, press the Refresh button.  
Note: check that the signal strength is greater than 30%, if not, bring the router closer or install a repeater or signal amplifier.  
Click Next.



Please select your current wireless network:

Site Survey

SSID	BSSID	RSSI	Channel
<input checked="" type="radio"/> iPhone di Giacomo	EE:25:EF:6C:31:18	100	6
<input type="radio"/> ZcsWiFi	FE:EC:DA:1D:C3:9	86	1
<input type="radio"/> ZcsHotSpot	FC:EC:DA:1D:C3:9	86	1
<input type="radio"/> WLAN	E:EC:DA:1D:C3:9	86	1
<input type="radio"/> ZcsHotSpot	FC:EC:DA:1D:C8:A3	57	11
<input type="radio"/> WLAN	E:EC:DA:1D:C8:A3	57	11
<input type="radio"/> ZcsWiFi	FE:EC:DA:1D:C8:A3	54	11
<input type="radio"/> WLAN	E:EC:DA:1D:C8:8B	45	1
<input type="radio"/> ZcsWiFi	FE:EC:DA:1D:C8:8B	37	1
<input type="radio"/> ZcsHotSpot	FC:EC:DA:1D:C8:8B	35	1

★Note: When RSSI of the selected WiFi network is lower than 15%, the connection may be unstable, please select other available network or shorten the distance between the device and router.

Refresh

Add wireless network manually:

Network name (SSID)  
(Note: case sensitive)

Encryption method

Encryption algorithm

Next

1 2 3 4

Figure 44 – Screen for selecting the available wireless network (1)

- 8) Enter the password of the Wi-Fi network (Wi-Fi modem), clicking on Show Password to make sure it is correct; the password should not contain special characters (&, #, %) and spaces.  
Note: During this step, the system is not able to ensure that the password entered is the one actually requested by the modem, therefore please make sure you enter the correct password.  
Also check that the box below is set to Enable.  
Then click “Next” and wait a few seconds for verification.



Please fill in the following information:

Password (8-64 bytes)  
(Note: case sensitive)   
 Show Password

Obtain an IP address automatically

IP address

Subnet mask

Gateway address

DNS server address

1 2 3 4

Figure 45 – Screen for entering the password of the wireless network (2)

9) Click “Next” again without ticking any of the options relating to the system security.

### Enhance Security

You can enhance your system security by choosing the following methods

- Hide AP
- Change the encryption mode for AP
- Change the user name and password for Web server

1 2 3 4

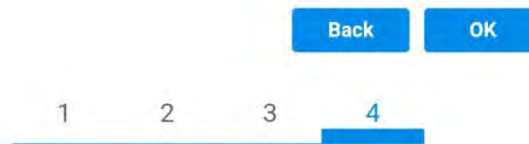
Figure 46 – Screen for setting the security options (3)

10) Click “OK”.

**Setting complete!**

Click OK, the settings will take effect and the system will restart immediately.

If you leave this interface without clicking OK, the settings will be ineffective.



**Figure 47 – Final configuration screen (4)**

- 11) At this point, if the configuration of the adapter is successful, the last configuration screen will appear, and the telephone or PC will unpair from the inverter’s Wi-Fi network.
- 12) Manually close the web page with the Close key on the PC or remove it from the background of the telephone.

**Setting complete! Please close this page manually!**

Please login our management portal to monitor and manage your PV system. (Please register an account if you do not have one.)

To re-login the configuration interface, please make sure that your computer or smart phone

Web Ver:1.0.24

**Figure 48 – Successful configuration screen**

### 12.1.3. Verification

To verify the correct configuration, connect to it again and access the status page. Check the following information:

- a. Wireless STA mode
  - i. Router SSID > Router name
  - ii. Signal Quality > other than 0%
  - iii. IP address > other than 0.0.0.0
- b. Remote server information
  - i. Remote server A > Connected

Wireless STA mode		Enable
Router SSID	iPhone di Giacomo	
Signal Quality	0%	
IP address	0.0.0.0	
MAC address	98:d8:63:54:0a:86	
<b>- Remote server information</b>		
Remote server A	Not connected	

Figure 49 – Status screen

### Status of LEDs present on the adapter

- 1) Initial status:
  - NET (left LED ): off
  - COM (central LED): steady on
  - READY (right LED): flashing on



Figure 50 – Initial status of LEDs

2) Final status:

- NET (left LED): steady on
- COM (central LED): steady on
- READY (right LED): flashing on



Figure 51 – Final status of LEDs

If the NET LED does not light up or if the Remote Server A option in the Status page still shows “Not Connected”, the configuration was not successful, i.e. the wrong router password was entered or the device was disconnected during connection.

It is necessary to reset the adapter:

- Press the Reset button for 10 seconds and release
- After a few seconds, the LEDs will turn off and READY will start to flash quickly
- The adapter has now returned to its initial state. At this point, the configuration procedure can be repeated again.

The adapter can only be reset when the inverter is switched on.



Figure 52 – Reset button on the Wi-Fi adapter

## 12.1.4. Troubleshooting

### Status of LEDs present on the adapter

- 1) Irregular communication with inverter
  - NET (left LED): steady on
  - COM (central LED): off
  - READY (right LED): flashing on



Figure 53 – Irregular communication status between inverter and Wi-Fi

- Check the Modbus address set on the inverter:  
Enter the main menu with the ESC key (first key on the left), go to System Info and press ENTER to enter the submenu. Scroll down to the Modbus address parameter and make sure it is set to 01 (and in any case, other than 00).

If the value is not 01, go to “Settings” (basic settings for hybrid inverters) and enter the Modbus Address menu where the 01 value can be set.

- Check that the Wi-Fi adapter is correctly and securely connected to the inverter, making sure to tighten the two cross-head screws provided.
- Check that the Wi-Fi symbol is present in the top right-hand corner of the inverter's display (steady or flashing).



Figure 54 – Icons on the display of LITE single-phase inverters (left) and three-phase or hybrid inverters (right)

- Restart the adapter:



- Press the reset button for 5 seconds and release
- After a few seconds, the LEDs will turn off and will start to flash quickly
- The adapter will now be reset without having lost the configuration with the router

## 2) Irregular communication with remote server

- NET (left LED ): off
- COM (central LED): on
- READY (right LED): flashing on



Figure 55 – Irregular communication status between Wi-Fi and remote server

- Check that the configuration procedure has been carried out correctly and that the correct network password has been entered.
- When searching for the Wi-Fi network using a smartphone or PC, make sure that the Wi-Fi signal is strong enough (a minimum RSSI signal strength of 30% is required during configuration). If necessary, increase it by using a network extender or a router dedicated to inverter monitoring.
- Check that the router has access to the network and that the connection is stable; check that a PC or smartphone can access the Internet
- Check that port 80 of the router is open and enabled to send data
- Reset the adapter as described in the previous section

If, at the end of the previous checks and subsequent configuration, Remote server A is still “Not Connected” or the NET LED is off, there may be a transmission problem at the home network level and, more specifically, that data between the router and server is not being transmitted correctly. In this case, it is advisable to carry out checks at the router level in order to ensure that there are no obstructions on the output of data packets to our server.

To make sure that the problem lies in the home router and to exclude problems with the Wi-Fi adapter, configure the adapter using the Wi-Fi hotspot function on your smartphone as a reference wireless network.

## • Using an Android mobile phone as a modem

- a) Check that the 3G/LTE connection is active on your smartphone. Go to the Settings menu of the operating system (the gear icon on the screen with a list of all the apps installed on the phone),



select “Other” from the Wireless and networks menu and make sure that the Network type is set to 3G/4G/5G.

- b) In the Android settings menu, go to Wireless & networks > Other. Select Mobile Hotspot/Tethering, and then enable the Wi-Fi mobile hotspot option; wait a few seconds for the wireless network to be created. To change the name of the wireless network (SSID) or your password, select Configure Wi-Fi hotspot.

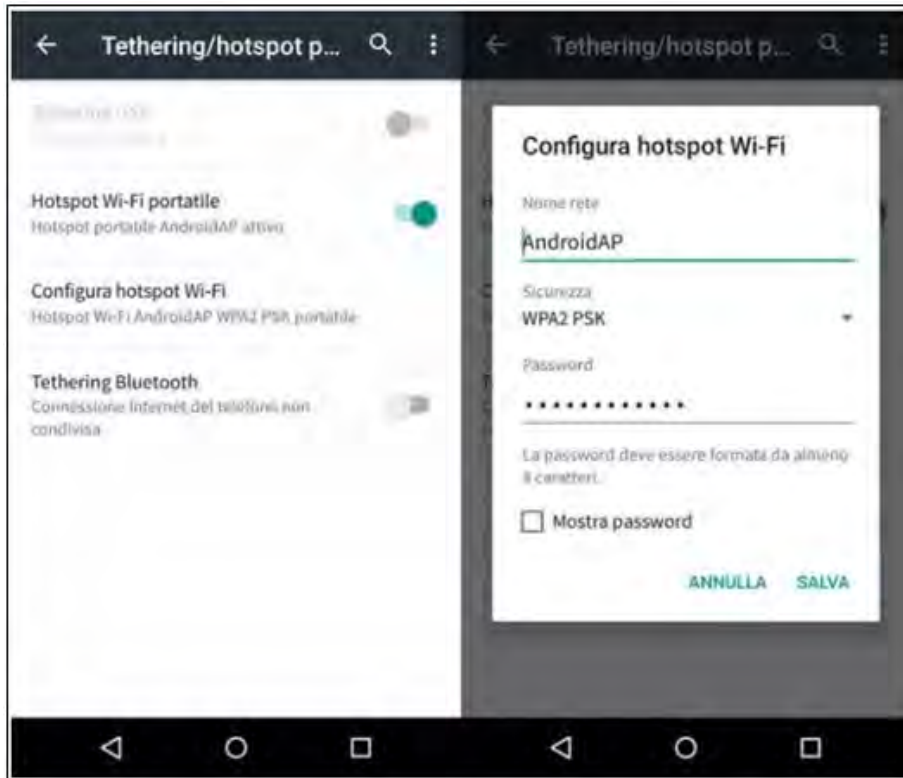


Figure 56 – Configuration of an Android smartphone as a hotspot router

- **Using an iPhone as a modem**

- a) In order to share the iPhone connection, verify that the 3G/LTE network is active by going to Settings > Mobile Phone, and making sure that the “Voice and data” option is set to 5G, 4G or 3G. To enter the iOS settings menu, click the grey gear icon on the home screen of your phone.
- b) Go to the Settings menu > Personal Hotspot and turn on the Personal Hotspot option. The hotspot is now enabled. To change the password of the Wi-Fi network, select Wi-Fi password from the personal hotspot menu.

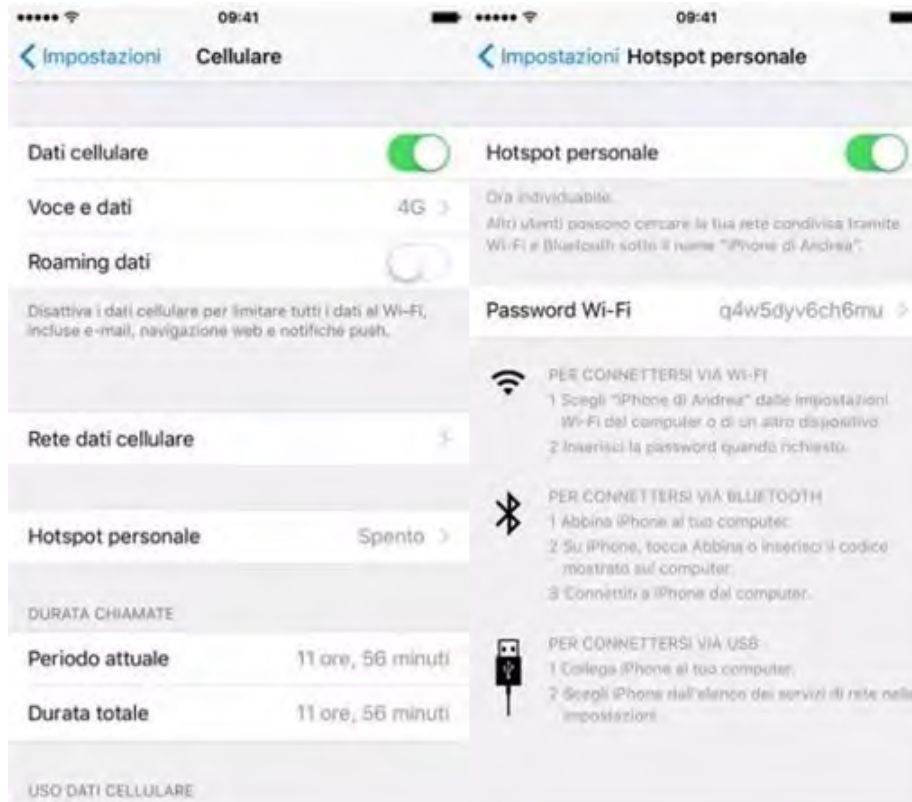


Figure 57 – Configuration of an iOS smartphone as a hotspot router

At this point, it is necessary to re-configure the Wi-Fi adapter using a PC or smartphone other than the one used as a modem.

During this procedure, when asked to select the Wi-Fi network, choose the one activated by the smartphone and then enter the password associated with it (which can be changed from the personal hotspot settings). If at the end of configuration, “Connected” appears next to “Remote Server A”, then the problem is with the home router.

It is therefore advisable to check the brand and model of the home router you are trying to connect to the Wi-Fi adapter; some router brands may have closed communication ports. In this case, contact the customer service of the router’s manufacturer and ask them to open port 80 (direct from the network to external users).

## 12.2. Ethernet adapter

### 12.2.1. Installation

Installation must be carried out for all inverters compatible with the adapter. However, the procedure is quicker and easier as there is no need to open the front cover of the inverter. Proper operation of the device requires the presence of a modem correctly connected to the network and in operation in order to achieve stable data transmission from the inverter to the server.

In order to monitor the inverter, the RS485 communication address must be set to 01 directly from the display.

#### Installation tools:

- Cross screwdriver
- Ethernet adapter
- Shielded network (Cat. 5 or Cat. 6) crimped with RJ45 connectors

- 1) Switch off the inverter following the procedure described in this manual.
- 2) Remove the cover for accessing the Wi-Fi/Eth connector on the bottom of the inverter by unscrewing the two cross-head screws (a), or by unscrewing the cover (b), depending on the inverter model, as shown in the figure.

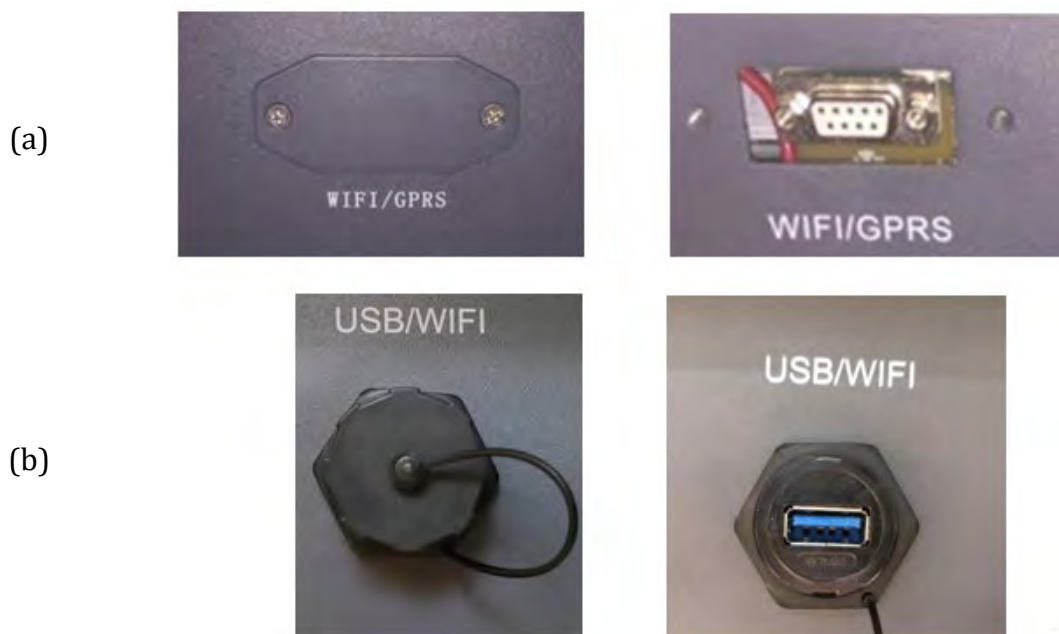


Figure 58 – Port of the Ethernet adapter

- 3) Remove the ring nut and the waterproof cable gland from the adapter to allow the network cable to pass through; then insert the network cable network into the appropriate port on the inside of the adapter and tighten the ring nut and cable gland to ensure a stable connection.

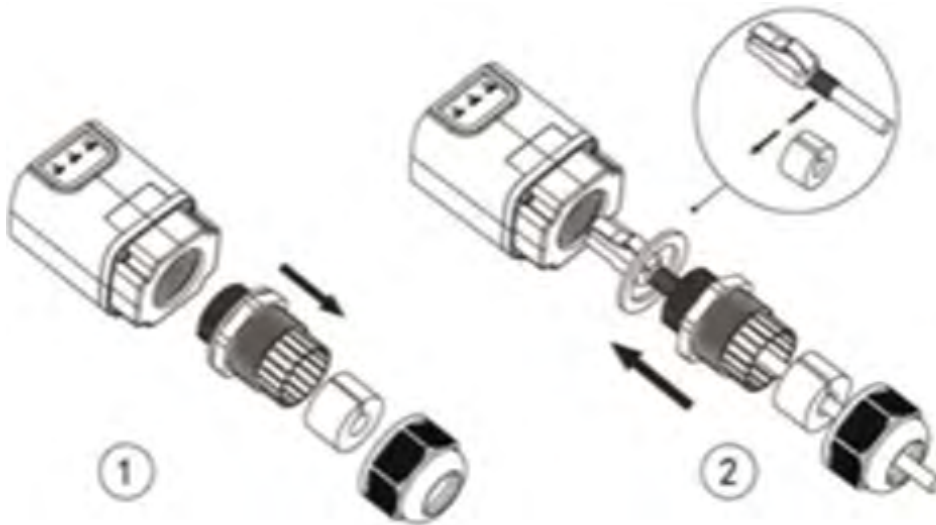


Figure 59 - Inserting the network cable inside the device

- 4) Connect the Ethernet adapter to the appropriate port, making sure to follow the direction of the connection and ensure correct contact between the two parts.

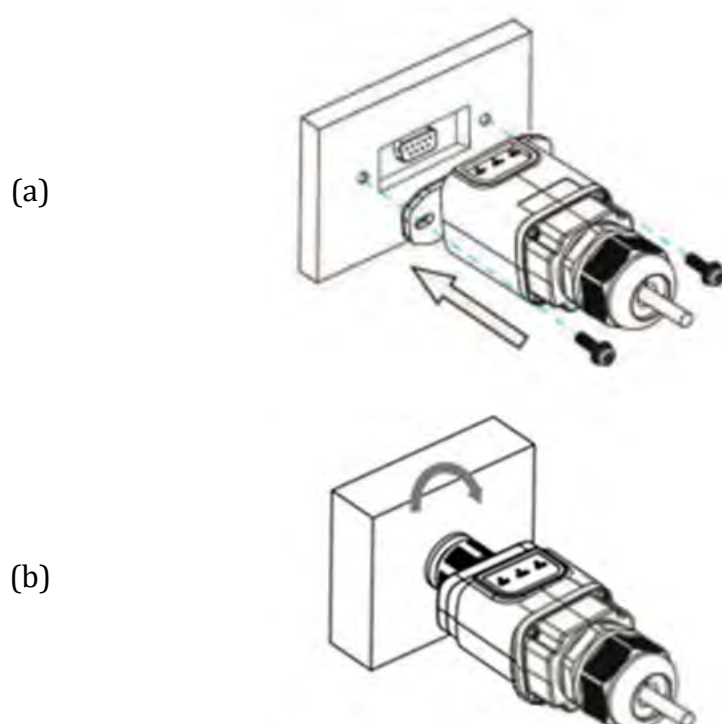


Figure 60 - Inserting and securing the ethernet adapter

- 5) Connect the other end of the network cable to the ETH output (or equivalent) of the modem or a suitable data transmission device.

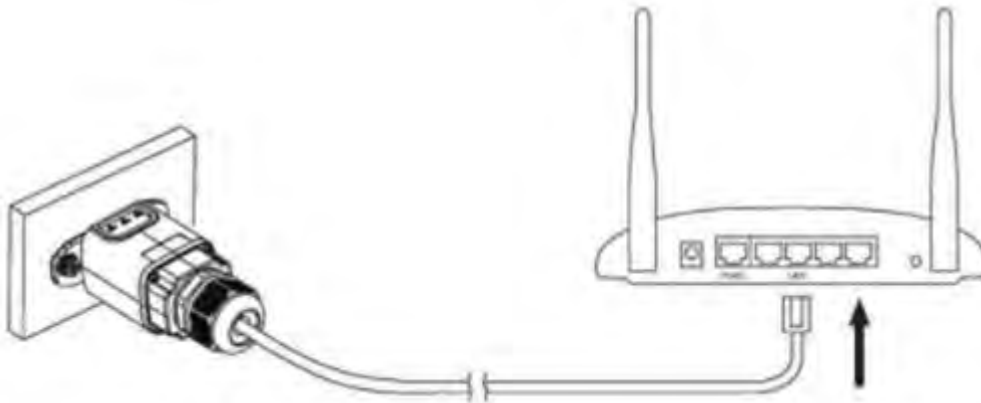


Figure 61 – Connecting the network cable to the modem

- 6) Switch on the inverter by following the procedure described in the manual.
- 7) Unlike Wi-Fi cards, the Ethernet adapter does not need to be configured and starts transmitting data shortly after the inverter is switched on.

### 12.2.2. Verification

Wait two minutes after installing the adapter, and check the status of the LEDs on the device.

#### Status of LEDs present on the adapter

- 1) Initial status:
  - NET (left LED ): off
  - COM (central LED): steady on
  - SER (right LED): flashing on



Figure 62 – Initial status of LEDs



- 2) Final status:  
NET (left LED): steady on  
COM (central LED): steady on  
SER (right LED): flashing on



Figure 63 – Final status of LEDs

### 12.2.3. Troubleshooting

#### Status of LEDs present on the adapter

- 1) Irregular communication with inverter
- NET (left LED): steady on
  - COM (central LED): off
  - SER (right LED): flashing on



Figure 64 – Irregular communication status between the inverter and adapter



- Check the Modbus address set on the inverter:  
 Enter the main menu with the ESC key (first key on the left), go to System Info and press ENTER to enter the submenu. Scroll down to the Modbus address parameter and make sure it is set to 01 (and in any case, other than 00).  
 If the value is not 01, go to “Settings” (basic settings for hybrid inverters) and enter the Modbus Address menu where the 01 value can be set.
- Check that the Ethernet adapter is correctly and securely connected to the inverter, making sure to tighten the two cross-head screws provided. Check that the network cable is correctly inserted into the device and modem, and that the RJ45 connector is correctly crimped.

## 2) Irregular communication with remote server

- NET (left LED ): off
- COM (central LED): on
- SER (right LED): flashing on



Figure 65 – Irregular communication status between the adapter and remote server

- Check that the router has access to the network and that the connection is stable; check that a PC can access the Internet

Check that port 80 of the router is open and enabled to send data.

It is advisable to check the brand and model of the home router you are trying to connect to the Ethernet adapter; some router brands may have closed communication ports. In this case, contact the customer service of the router’s manufacturer and ask them to open port 80 (direct from the network to external users).

## 12.3. 4G adapter

The ZCS 4G adapters are sold with a virtual SIM integrated into the device with data traffic fee included for 10 years, which is adequate for the proper transmission of data to monitor the inverter.

In order to monitor the inverter, the RS485 communication address must be set to 01 directly from the display.

### 12.3.1. Installation

Installation must be carried out for all inverters compatible with the adapter. However, the procedure is quicker and easier as there is no need to open the front cover of the inverter.

#### Installation tools:

- Cross screwdriver
- 4G adapter

- 1) Switch off the inverter following the procedure described in this manual.
- 2) Remove the cover for accessing the Wi-Fi/ GPRS connector on the bottom of the inverter by unscrewing the two cross-head screws (a), or by unscrewing the cover (b), depending on the inverter model, as shown in the figure.



Figure 66 – Port of the 4G adapter

- 3) Insert the 4G adapter into the appropriate port, making sure to follow the direction of the connection and ensure correct contact between the two parts. Secure the 4G adapter by tightening the two screws inside the package.

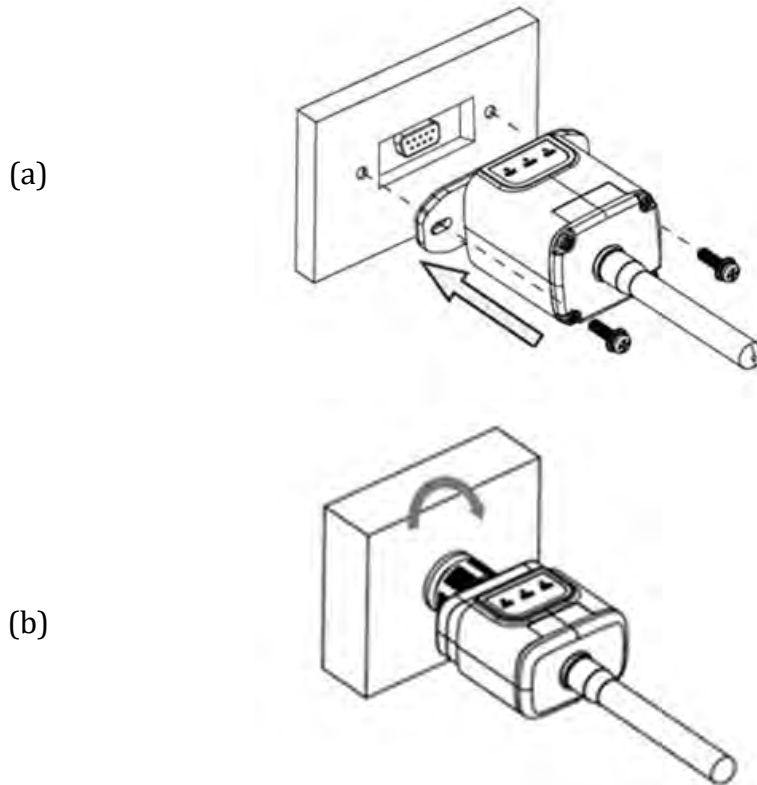


Figure 67 - Inserting and securing the 4G adapter

- 4) Switch on the inverter by following the procedure described in the manual.
- 5) Unlike Wi-Fi cards, the 4G adapter does not need to be configured and starts transmitting data shortly after the inverter is switched on.

### 12.3.2. Verification

After installing the adapter, within the next 3 minutes check the status of the LEDs on the device to ensure that the device is configured correctly.

#### Status of LEDs present on the adapter

1) Initial status:

- NET (left LED ): off
- COM (central LED): flashing on
- SER (right LED): flashing on



Figure 68 – Initial status of LEDs

2) Registration:

- NET (left LED): flashes rapidly for about 50 seconds; the registration process takes about 30 seconds
- COM (central LED): flashes rapidly 3 times after 50 seconds

3) Final status (approx. 150 seconds after the inverter has started):

- NET (left LED): flashing on (off and on at equal intervals)
- COM (central LED): steady on
- SER (right LED): steady on



Figure 69 – Final status of LEDs

### Status of LEDs present on the adapter

#### 1) Irregular communication with inverter

- NET (left LED): on
- COM (central LED ): off
- SER (right LED): on



Figure 70 – Irregular communication status between inverter and adapter

- Check the Modbus address set on the inverter:  
Enter the main menu with the ESC key (first key on the left), go to System Info and press ENTER to enter the submenu. Scroll down to the Modbus address parameter and make sure it is set to 01 (and in any case, other than 00).

If the value is not 01, go to “Settings” (basic settings for hybrid inverters) and enter the Modbus Address menu where the 01 value can be set.

- Check that the 4G adapter is correctly and securely connected to the inverter, making sure to tighten the two cross-head screws provided.

2) Irregular communication with remote server:

- NET (left LED): flashing on
- COM (central LED): on
- SER (right LED): flashing on























Figure 71 – Irregular communication status between the adapter and remote server

- Check that the 4G signal is present in the installation location (the adapter uses the Vodafone network for 4G transmission; if this network is not present or the signal is weak, the SIM will use a different network or will limit the data transmission speed). Ensure that the installation location is suitable for 4G signal transmission and that there are no obstacles that could affect data transmission.
- Check the status of the 4G adapter and that there are no external signs of wear or damage.



## 12.4. Datalogger

ZCS monitoring				
Product code	Product photo	APP monitoring	Portal monitoring	Possibility to send commands and to update the inverter remotely in case of technical support
ZSM-WIFI				
ZSM-ETH				
ZSM-4G				
Datalogger 4-10 Inverters				
Datalogger up to 31 Inverters				

### 12.4.1. Preliminary notes on how to configure the datalogger

The AzzurroZCS inverters can be monitored via a datalogger connected to a Wi-Fi network present at the place of installation or via an ethernet cable connected to a modem.

The inverters are connected in a daisy chain to the datalogger via a RS485 serial line.

- Datalogger up to 4 inverters (code ZSM-DATALOG-04): allows to monitor up to 4 inverters.

It can be connected to the network via an Ethernet or Wi-Fi network.

- Datalogger up to 10 inverters (code ZSM-DATALOG-10): allows to monitor up to 10 inverters.

It can be connected to the network via an Ethernet or Wi-Fi network.



Figure 72 – Diagram for connecting the ZSM-DATALOG-04 / ZSM-DATALOG-10 datalogger

- Datalogger up to 31 inverters (code ZSM-RMS001/M200): allows to monitor up to 31 inverters or a system with a maximum installed power of 200kW.

It can be connected to the network via an Ethernet cable.

- Datalogger up to 31 inverters (code ZSM-RMS001/M1000): allows to monitor a maximum of 31 inverters or a system with a maximum installed power of 1000kW.

It can be connected to the network via an Ethernet cable.



Figure 73 – Diagram showing the operation of the ZSM-RMS001/M200 / ZSM-RMS001/M1000 datalogger

All these devices carry out the same function, i.e. they transmit data from the inverters to a web server to allow remote monitoring of the system either through the “Azzurro System” app or through the [www.zcsazzurroportal.com](http://www.zcsazzurroportal.com) website.

All the Azzurro ZCS inverters can be monitored using the datalogger; different models or families of inverters can also be monitored.

## 12.4.2. Electrical connections and configuration

All the Azzurro ZCS inverters have at least one RS485 connection point.

The connections can be made via the green terminal block or via the RJ45 plug inside the inverter. Use positive and negative conductors. There is no need to use a conductor for the GND. This applies to both the terminal block and the plug.

The serial line can be created using a shielded RS485 certificated cable.

In case of monitoring of multiple inverters, continue the shielding of the cables when entering the exit under the COM port of the inverter. Connect the shield to the ground on one side (inverter side).

- 1) In the case of three-phase inverters, a suitably crimped network cable with a RJ45 connector can also be used:
  - a. Place the blue cable in position 4 of the RJ45 connector and the white-blue cable in position 5 of the RJ45 connector, as shown in the figure below.
  - b. Insert the connector into the 485-OUT terminal.
  - c. If there is more than one three-phase inverter, insert another connector in the 485-IN terminal to connect to the 485-OUT input of the next inverter.

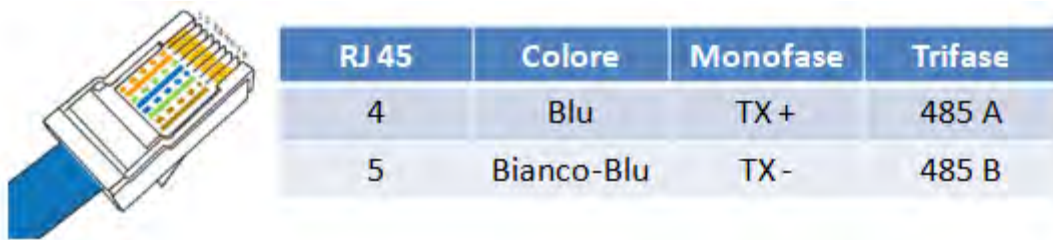


Figure 74 - Pin out for connecting the RJ45 connector

- 2) Daisy chain
  - a. Insert the blue cable into input A1 and the white-blue cable into input B1.
  - b. If there is more than one three-phase inverter, insert a blue cable into input A2 and a white-blue cable into input B2 and connect them to the respective A1 and B1 inputs of the next inverter.

Some inverters have both an RS485 terminal block and RJ45 plugs. This is shown in detail in the figure below.

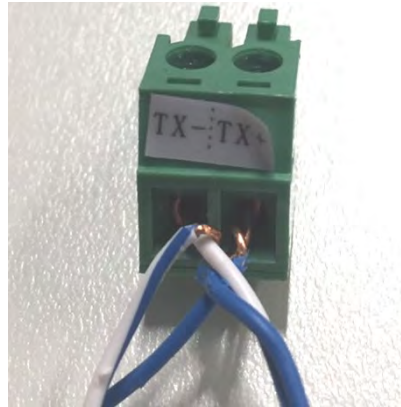


Figure 75 - Tightening the network cable to the RS485 terminal block

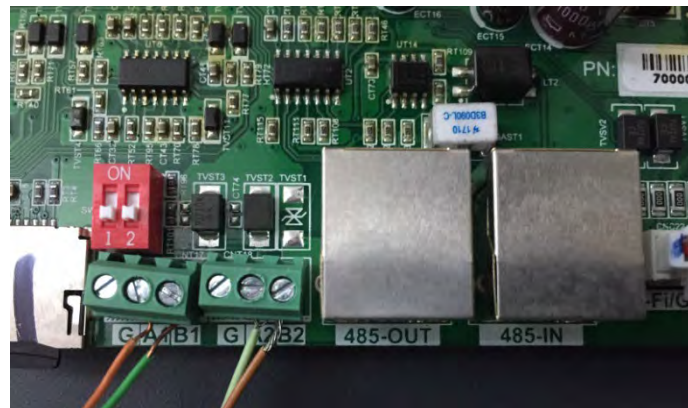


Figure 76 - Connecting the serial line via the RS485 terminal block and via the RJ45 plug

For the 3PH HYD5000-HYD20000-ZSS three-phase hybrid inverter, use only one positive and one negative of those shown in the figure below.





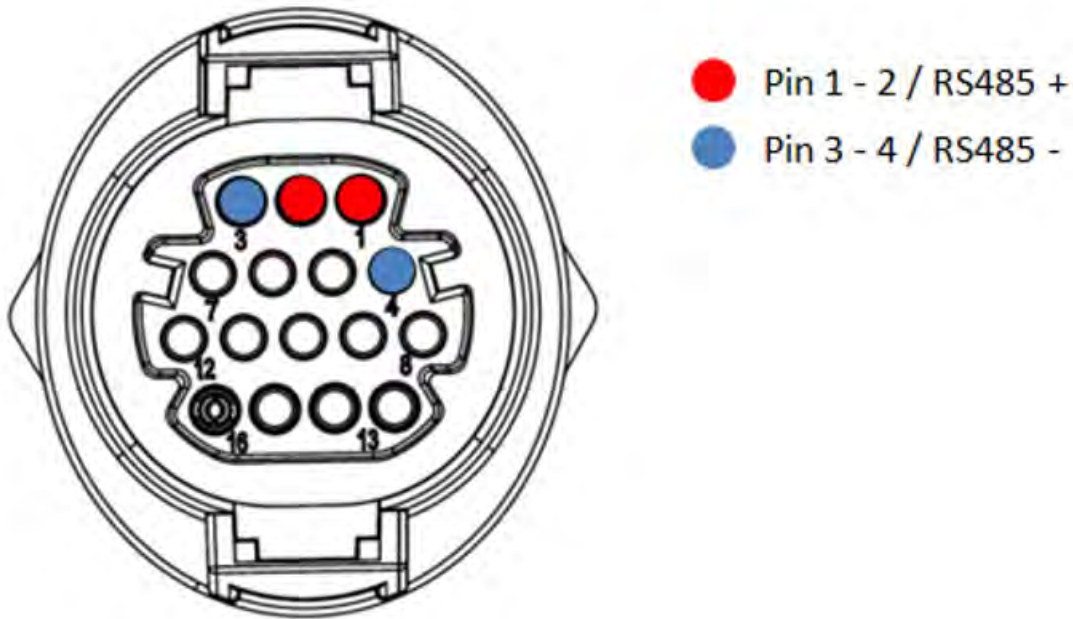


Figure 77 - Connecting the serial line via the communication connector for 3PH HYD5000-HYD20000-ZSS

For the 3PH 250-255KTL-HV, 250-350KTL HVZ0 three-phase inverter and the 3000-6000 TLM-V3 photovoltaic inverter, use only one positive and one negative of those shown in the figure below.

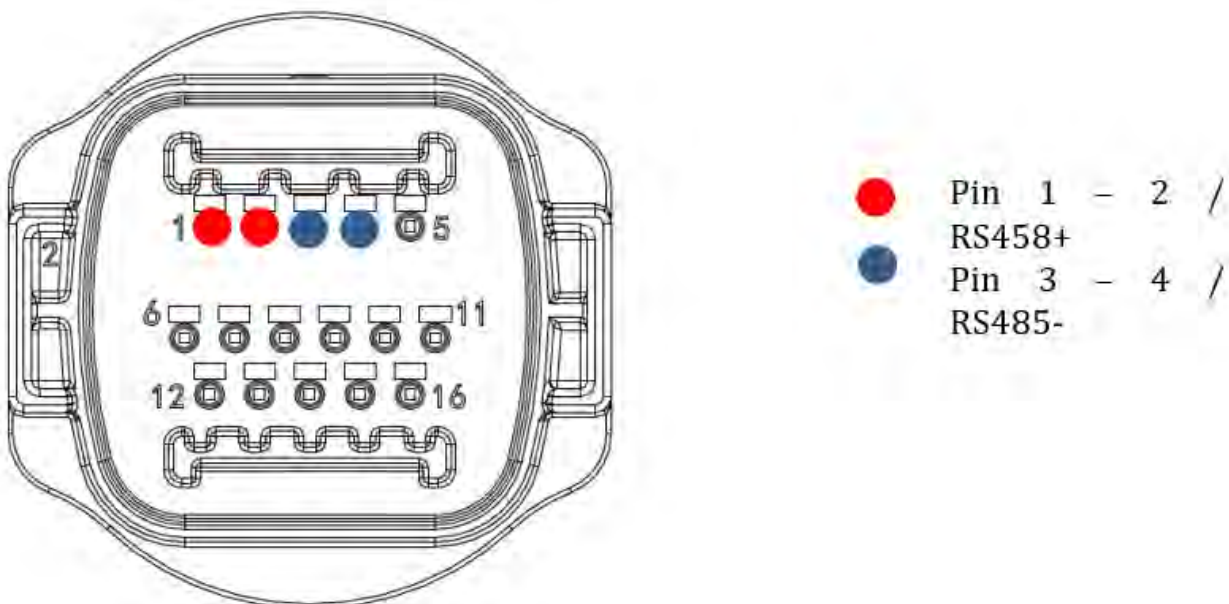
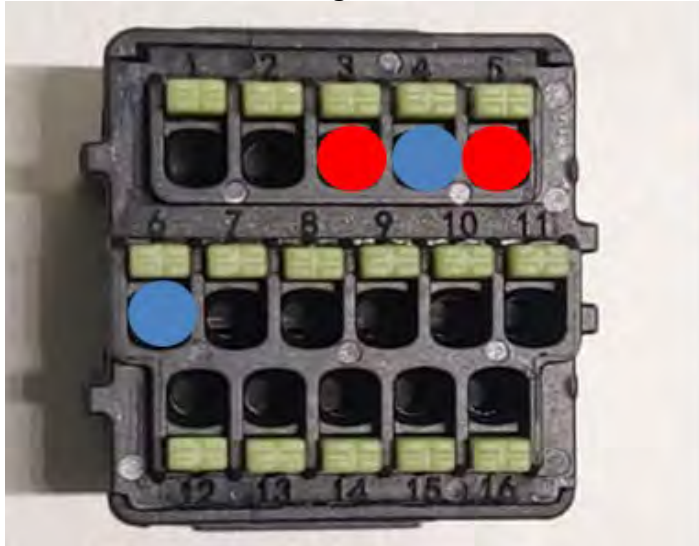


Figure 78 - Connecting the serial line via the communication connector for 1PH 3000-6000 TLM-V3, 3PH 250-255KTL-HV

For the 1PH HYD3000-HYD6000-ZSS-HP single-phase hybrid inverter, use only one positive and one negative of those shown in the figure below.



- Pin 3 - 5 / RS485 +
- Pin 4 - 6 / RS485 -

Figure 79 – Connecting the serial line via the communication connector for 1PH HYD3000-HYD6000-HP

- c. Position the dip switches of the last inverter of the daisy chain as shown in the figure below for activating the 120 Ohm resistor and closing the communication chain. If there are no switches, physically connect a 120 Ohm resistor to terminate the bus.

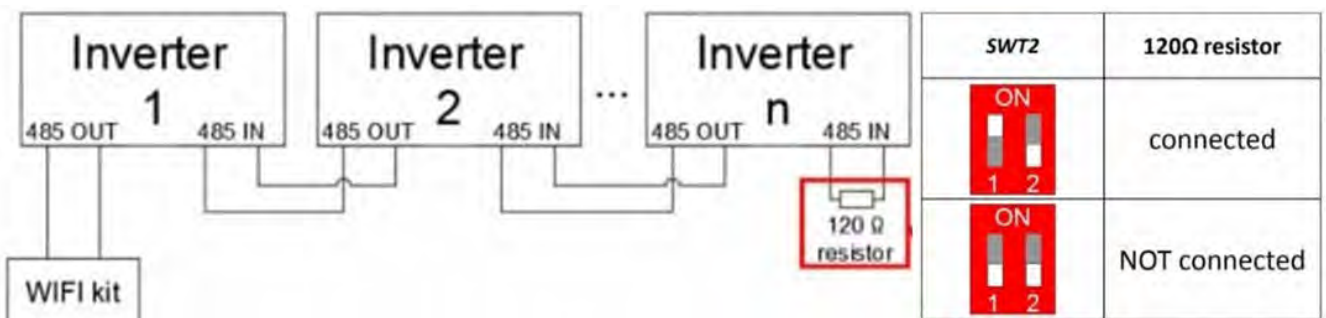


Figure 80 – Positioning of dip switches to connect the isolation resistor

- 3) Check that the RS485 icon is shown on the display of all the inverters. This indicates that the inverters are actually connected via the serial line. If this symbol does not appear, check that the connection is correct, as indicated in this guide.



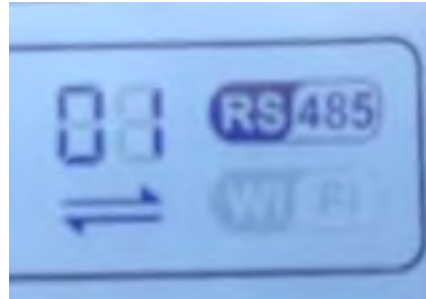


Figure 81 – RS485 symbol on the display of the inverter

- 4) Set a sequential Modbus address on each inverter connected:
  - a. Enter the “Settings” menu.
  - b. Scroll to the submenu “Modbus Address.”
  - c. Change the digits and set an increasing address on each inverter, starting from 01 (first inverter) to the last inverter connected. The Modbus address will be shown on the display of the inverter alongside the RS485 symbol. There should be no inverters with the same Modbus address.

### 12.4.3. ZSM-DATALOG-04 AND ZSM-DATALOG-10 DEVICES

The initial status of the LEDs on the datalogger will be:

- POWER steady on
- 485 steady on
- LINK off
- STATUS steady on

### 12.4.4. WI-FI CONFIGURATION

To configure the datalogger via Wi-Fi, please refer to the chapter on monitoring systems, as the configuration is similar to that of any type of Wi-Fi adapter.

### 12.4.5. Ethernet configuration

- 1) Insert the RJ45 connector of the Ethernet cable in the ETHERNET input of the datalogger.



Figure 82 – Ethernet cable connected to the datalogger

- 2) Connect the other end of the Ethernet cable to the ETH output (or equivalent) of the modem or a suitable data transmission device.
- 3) Activate the search for Wi-Fi networks on your phone or PC in order to display all the networks visible from your device.



Figure 83 – Wi-Fi network search on iOS smartphone (left) and Android (right)

Note: Disconnect from any Wi-Fi networks to which you are connected by removing automatic access.



Figure 84 – Disabling automatic reconnection to a network

- 4) Connect to a Wi-Fi network generated by the datalogger (i.e. AP\_\*\*\*\*\*, where \*\*\*\*\* indicates the serial number of the datalogger shown on the label of the device), which operates as an Access Point.
- 5) Note: To ensure that the datalogger is connected to the PC or smartphone during the configuration procedure, enable automatic reconnection of the AP\_\*\*\*\*\* network.

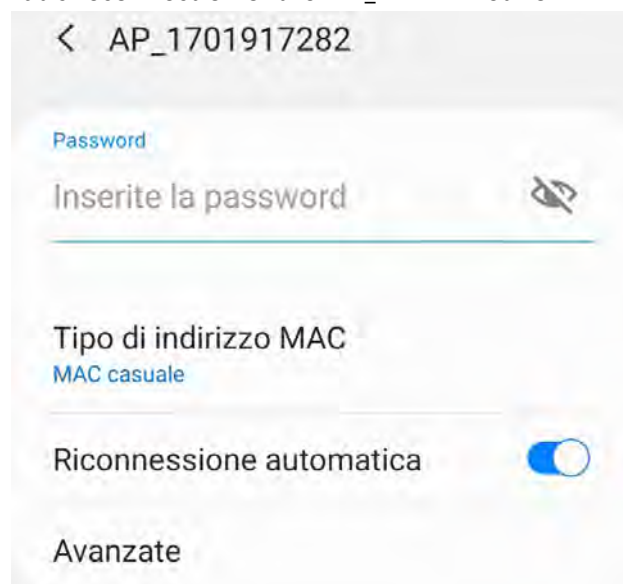


Figure 85 – Password entry prompt

Note: the Access Point is not able to provide internet access; confirm to maintain the Wi-Fi connection, even if internet is not available.



Figure 86 – Screen showing that the Internet cannot be accessed

- 6) Open a browser (Google Chrome, Safari, Firefox) and enter the IP address 10.10.100.254 in the address bar at the top of the screen.  
In the box that appears, enter “admin” as both Username and Password.



Figure 87 – Screen for logging into the web server to configure the datalogger

- 7) The status screen will open, showing the datalogger information such as serial number and firmware version.

Check that the fields relating to the Inverter Information are filled in with the information of all the inverters connected.

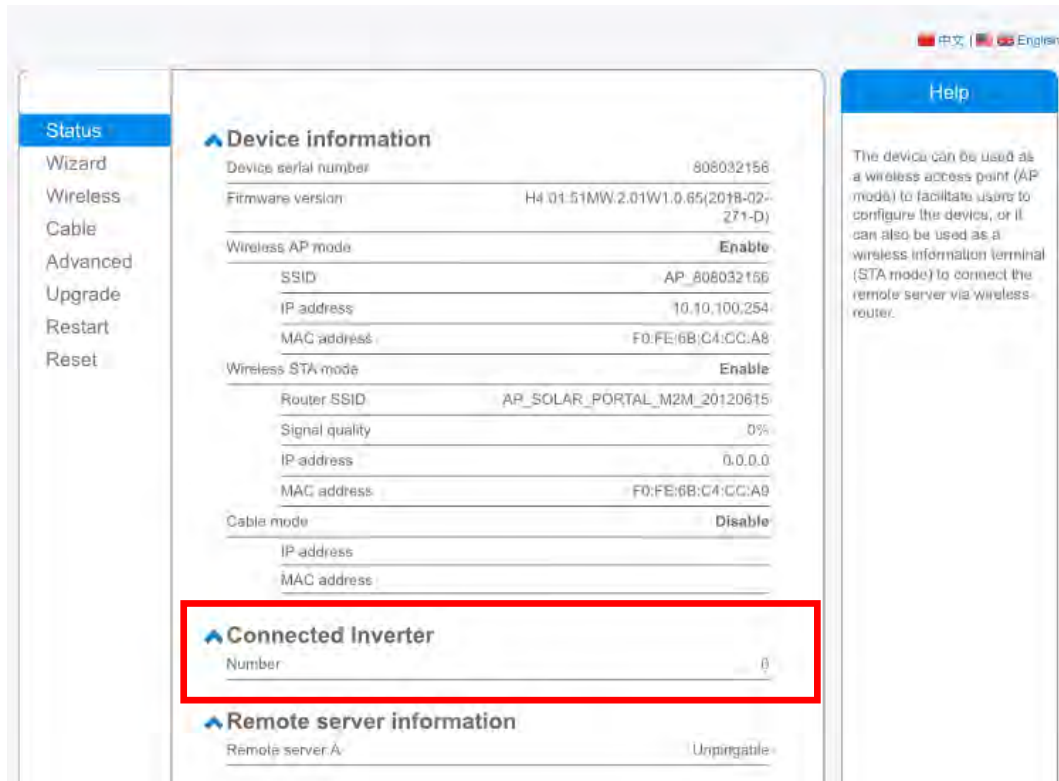


Figure 88 – Status Screen

- 8) Click on the Wizard setup button in the left-hand column.
- 9) Now click on the Start button to start the configuration wizard.

Dear user:

Thank you for choosing our device.  
Next, you can follow the setup wizard to complete the network setting step by step;  
or you can select the left menu for detailed settings.

★Note: Before setting, please make sure that your wireless or cable network is working.

Start

1 2 3 4 5 6 7

Figure 89 – Screen for starting (1) the Setup Wizard

10) Check the “Cable Connection” option and then click “Next.”

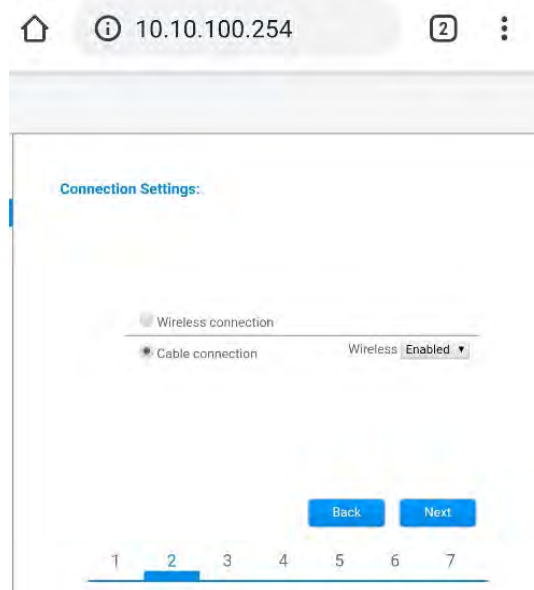


Figure 90 – Network cable connection selection screen

11) Make sure that the “Enable” option is selected to automatically obtain the IP address from your router, then click Next.

Please fill in the following information:

Obtain an IP address automatically	Enable ▾
IP address	0.0.0.0
Subnet mask	0.0.0.0
Gateway address	0.0.0.0
DNS server address	

Back Next

1 2 3 4 5 6 7

Figure 91 – Screen for automatically obtaining the IP address (5)



12) Click on Next without making any changes.

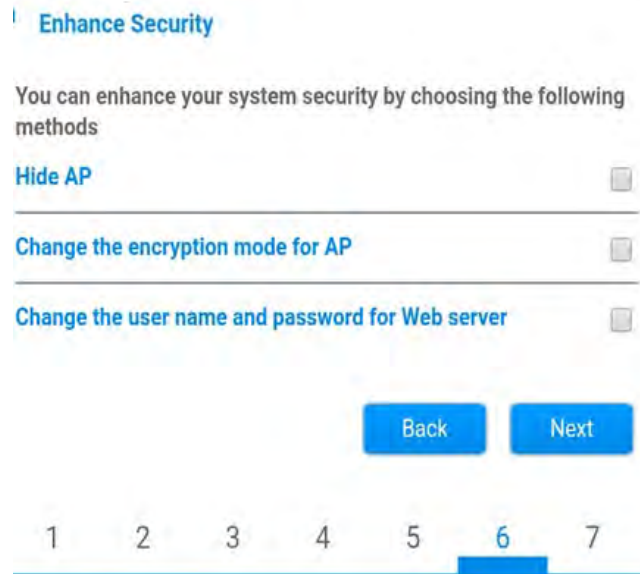


Figure 92 – Screen for setting the security options (6)

13) Complete the configuration procedure by clicking OK, as shown in the following screen.

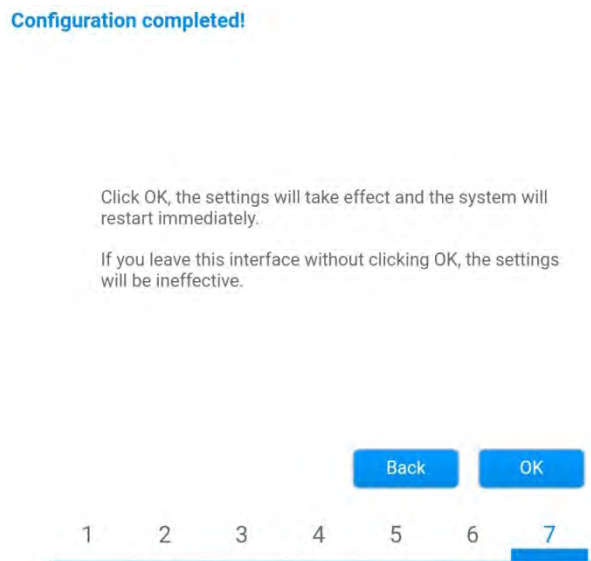


Figure 93 – Final configuration screen (7)

14) If the configuration procedure is successful, the following screen will appear:

If this screen does not appear, try refreshing the browser page.

The screen will prompt you to manually close the page; close the page from the background of your phone or from the close button on your PC.

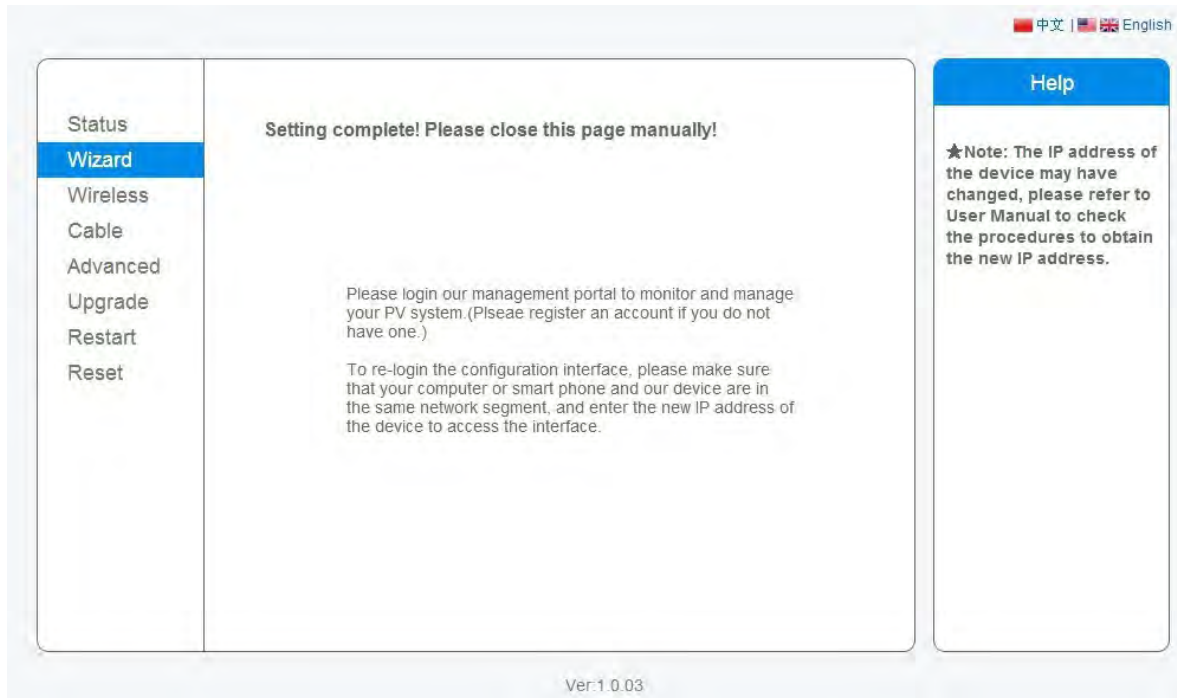


Figure 94 – Successful configuration screen

### 12.4.6. Checking that the datalogger has been configured correctly

Wait two minutes after completing the configuration of the device. First of all, check that the LINK LED on the device is on and steady.



Figure 95 – LED indicating the correct configuration of the datalogger

Enter the IP address 10.10.100.254 again, and the login credentials (“admin” for both username and password). Once logged in, the Status screen will appear, where the following information can be checked:

- Check Wireless STA mode (if the datalogger has been configured via Wi-Fi)
  - Router SSID > Router name
  - Signal Quality > other than 0%
  - IP address > other than 0.0.0.0
- Check Cable mode (if the datalogger has been configured via Ethernet cable)
  - IP address > other than 0.0.0.0
- Check Remote server information
  - Remote server A > Pingable

Device information	
Device serial number	508263482
Firmware version	H4.01.51MW.2.01W1.0.74(2019-03-143-D)
Wireless AP mode	<b>Enable</b>
SSID	AP_508263482
IP address	10.10.100.254
MAC address	BC:54:F9:F6:B9:74
Wireless STA mode	<b>Enable</b>
Router SSID	iPhone di Giacomo
Signal quality	100%
IP address	172.20.10.10
MAC address	BC:54:F9:F6:B9:75
Cable mode	<b>Disable</b>
IP address	
MAC address	

Connected Inverter	
Type	ZCS
Number	1
Inverter serial number	ZA1ES111G8R273 ▼
Firmware version (main)	V550
Firmware version (slave)	—
Inverter model	ZA1ES111
Rated power	1 00 W
Current power	0 W
Yield today	0 kWh
Total yield	0 kWh
Alerts	F12F14
Last updated	0 min ago

Remote server information	
Remote server A	Pingable

**Figure 96 – Main status screen and checking of correct configuration**

Cable mode	<b>Enable</b>
IP address	192.168.0.177
MAC address	BC:54:F9:F6:B9:77

**Figure 96 – main status screen and checking of correct configuration**

If the Remote Server A item in the Status page is still “Unpingable”, the configuration was not successful, i.e. the incorrect router password was entered or the device was disconnected during connection.

It is necessary to reset the device:

- Select the Reset button in the left-hand column
- Press the OK button to confirm
- Close the web page and enter the Status page again. At this point, the configuration procedure can be

repeated again.

- Status
- Wizard
- Wireless
- Cable
- Advanced
- Upgrade
- Restart
- Reset**

### Restore factory setting

**★Important:**

After restoring factory settings, all users' configuration will be deleted. You can reconfigure it on <http://10.10.100.2>. Account and password are both "admin".

Are you sure to reset now?

OK

Back

Figure 97 – Reset Screen

## 12.4.7. ZSM-RMS001/M200 and ZSM-RMS001/M1000 Devices

### 12.4.7.1. Mechanical description and Datalogger interface

**Mechanical Dimensions:** 127mm x 134 x 52 mm

**Protection rating:** IP20

The usable ports are indicated below.

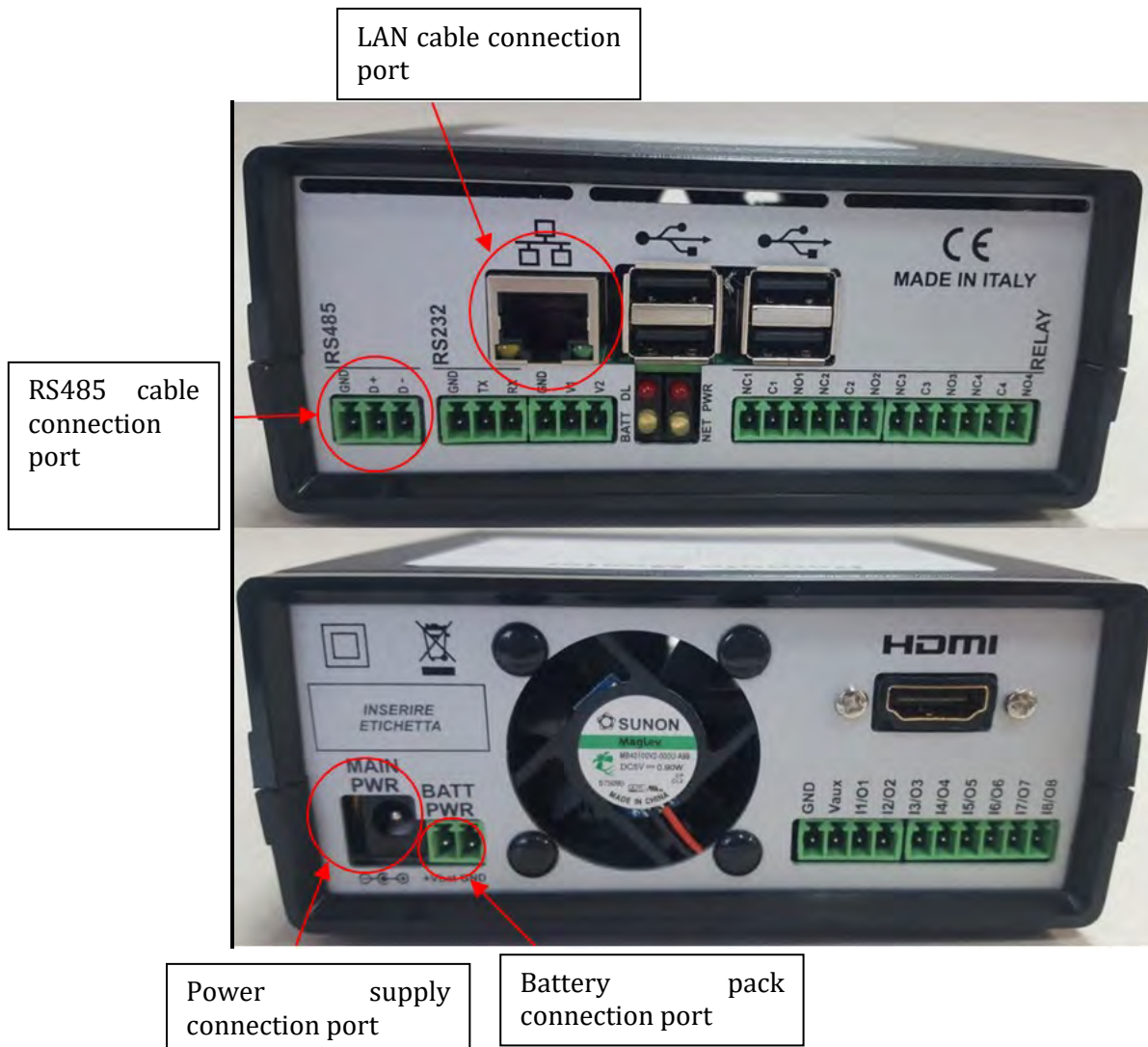


Figure 98 – Datalogger rear panel



### 12.4.7.2. Connecting the Datalogger to the inverters

A serial communication via RS485 cable is provided for connecting to the inverters. The GND cable does not need to be connected to the inverters. Follow the connections as shown in the table below.

Datalogger SIDE	BUS Signal	SENSOR SIDE (ZSM-IRR-TEMP-LM2)	Inverter SIDE
<b>D+</b> terminal	+	RS485+ <b>IB</b> terminal	+ <b>Tx</b> terminal
<b>D-</b> terminal	-	RS485- <b>IA</b> terminal	- <b>Tx</b> terminal

Table 3: Connecting the Datalogger to the inverters

### 12.4.7.3. Internet connection via Ethernet cable

In order to display the data measured and processed by the Datalogger in the portal, it is necessary to connect to the internet via LAN cable and open the following router ports:

- VPN ports: 22 and 1194
- HTTP ports: 80
- DB ports: 3050
- FTP ports: 20 and 21

The local network of the device is configured for DHCP, and it is not necessary to activate any communication port on the router. If you want to set a fixed network address, this must be provided at the time of ordering together with the gateway address.

### 12.4.7.4. Connecting the power supply and battery pack to the Datalogger

Once the RS485 Half Duplex cable has been connected, power the Datalogger by connecting the power supply unit (supplied with the datalogger) to the MAIN PWR input (12V DC - 1A).

In order to prevent possible voltage drops and/or power failures, it is recommended to also connect the battery pack, which is supplied with the datalogger. The battery pack should be connected to the +V<sub>bat</sub> and GND inputs of the BATT PWR connector, positive and negative respectively (i.e. red to the +V<sub>bat</sub> input and black to the GND input).

The battery pack (ZSM-UPS-001) can be purchased separately.

### 12.4.7.5. Connecting the LM2-485 PRO cell irradiance and temperature sensor to the datalogger

For proper installation, make sure to connect the sensor signal cable and the power cable.



In particular, the sensor of the signal cables must be connected in a daisy chain configuration to the remaining devices on the RS485 bus, as shown in the table below.

Datalogger SIDE	BUS Signal	SENSOR SIDE (ZSM-IRR-TEMP-LM2)	Inverter SIDE
<b>D+</b> terminal	+	RS485- <b>IB</b> terminal	<b>+Tx</b> terminal
<b>D-</b> terminal	-	RS485- <b>IA</b> terminal	<b>-Tx</b> terminal

To supply power to the sensor, the datalogger can be directly connected to the mains power, as shown in the table below, or connected to an external +12Vdc power supply.

Datalogger SIDE	SENSOR SIDE
<b>V1</b> terminal (12Vdc output voltage)	<b>RED +12V</b> Terminal
<b>GND</b> terminal (GND/RTN)	<b>BLACK 0V</b> Terminal
<b>V2</b> terminal (12Vdc driveable voltage)	

**Table 4: Electrical connection of the sensor to the datalogger (power supply)**

A stable communication in terms of signal and power supply, up to 200m, is guaranteed by using the RS485 cable, type Te.Co. 15166 (2x2x0,22+1x0,22)st/pu.

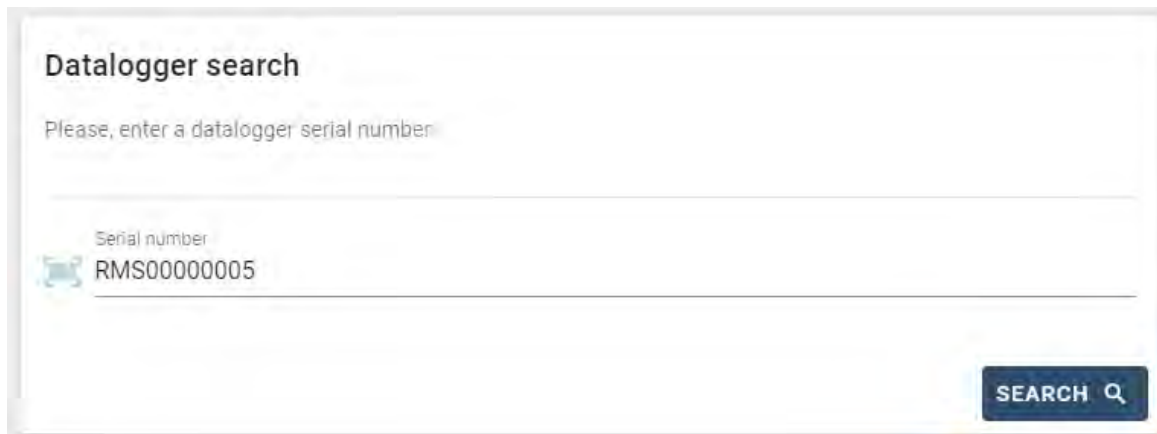
For longer distances, a connection to the signal side of the datalogger is recommended, and a connection to the +12V power supply via an external power supply unit.

## 12.4.8. Configuring the Datalogger

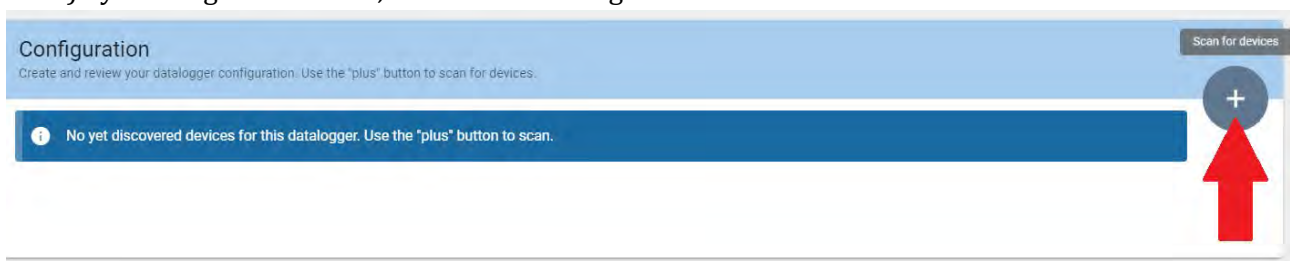
Connect to the website [dlconfig.it](http://dlconfig.it) and login by entering the temporary credentials: Username = admin and Password = admin.



In the screen that opens, enter the serial number(S/N) of the datalogger to be configured and click "SEARCH".



In the configuration page, you can search for any devices connected to the datalogger (inverter, meter or sensors) by clicking the + button, as shown in the figure.



A window will open where you can search for each type of device connected to the Datalogger, after indicating the range of addresses associated with the relative devices.

**Scan**  
Command the datalogger to perform a discovery. Find and confirm new and old devices.

Device Type

- Sensor
- Meter
- Inverter

Vendor

Protocol

CANCEL NEXT

If a meter is one of the devices connected to the Datalogger, select the type of Meter/Datalogger communication interface and the relative communication protocol.

**Scan**  
Command the datalogger to perform a discovery. Find and confirm new and old devices.

Device Type  
Meter

Vendor  
Algodue

Interface

- RS-485
- TCP

Protocol

CANCEL NEXT

**Scan**  
Command the datalogger to perform a discovery. Find and confirm new and old devices.

Device Type  
Meter

Vendor  
Algodue

Interface  
RS-485

Protocol

- ASCII
- RTU

CANCEL NEXT

Once this operation has been completed, update the new configuration by clicking “Confirm,” which will allow you to register the devices associated with the datalogger.

**Confirm changes**

State

Confirming new  1

Total now  1

**CONFIRM**

From this moment, the datalogger is correctly configured (all devices must be in the “saved” status) and therefore a new installation can be created on the ZCS Azzurro portal for associating the datalogger and the devices connected to it.

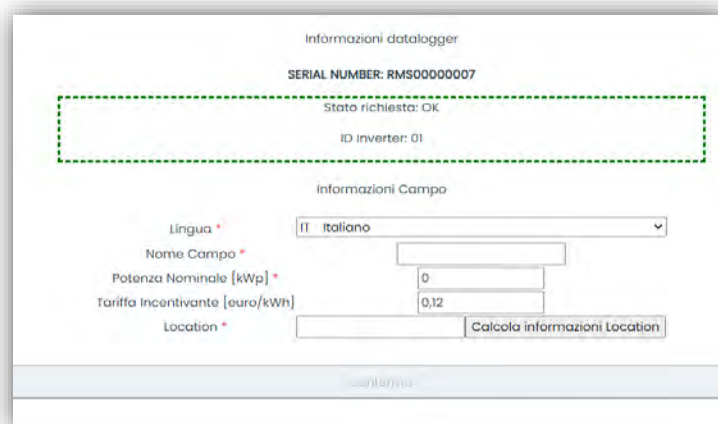
Configuration								Scan for devices
Create and review your datalogger configuration. Use the “plus” button to scan for devices.								+
Device Type	Direction	Vendor	Interface	Protocol	Serial number	Slave Id	Status	
Inverter		ZCS	RS-485	RTU	ZM1ES030JC4258	1	Saved	

### 12.4.8.1. Configuring the Datalogger on the ZCS Azzurro portal

Access the ZCS Azzurro portal (<https://www.zcsazzurroportal.com>). For new users, click “Sign up now” to register on the portal by entering your email, username and password. After logging into the portal, click “Configuration Panel”, and then select the option “Create field with Datalogger.” The “Create New Field” operation will be possible only if the user’s privileges allow acquiring new fields (at the time of registration the limit will be equal to 1, an upgrade is required to increase the limit).



Enter the serial number (S/N) of the datalogger and click “Check RMS”. If the datalogger has been configured correctly, a screen will open where you can enter the required information relating to the field to be installed.

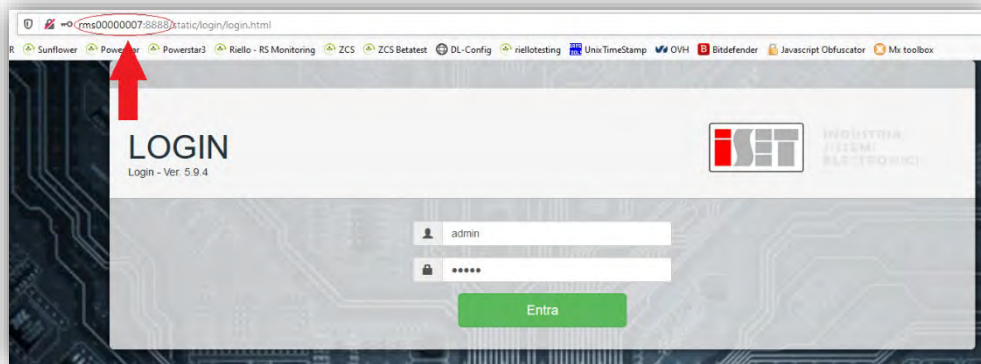


Once the “location” of the field has been entered, click “Calculate Location Information” to allow the system to obtain the latitude, longitude and time zone of the installation. Click “Confirm” to complete the configuration of the field. You only need to wait a few minutes to view the data flow on the ZCS Azzurro portal.

**ATTENTION: The location data is essential for the correct operation of the datalogger in the ZCS system. It is important to define it very carefully.**

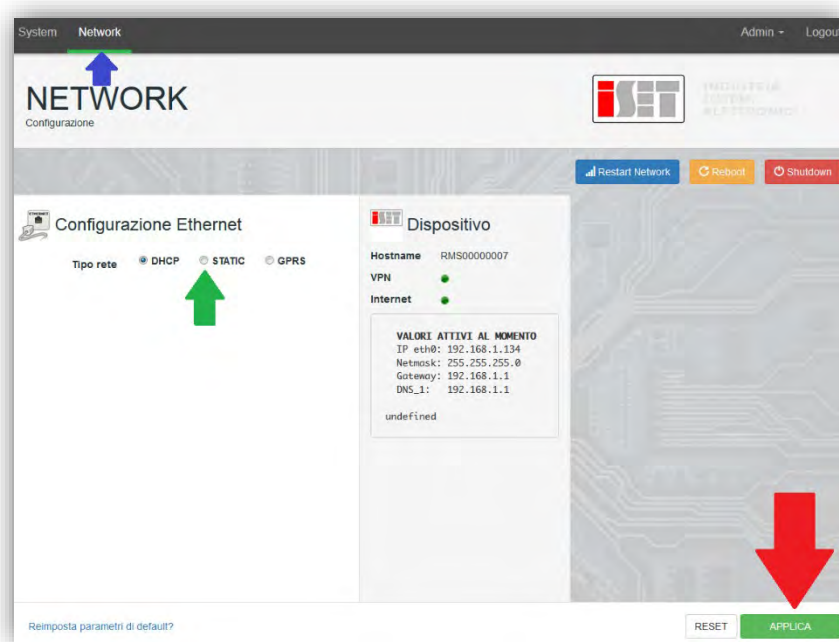
### 12.4.8.2. Network configuration

At the time of purchase, the Datalogger is configured in DHCP, i.e. dynamic configuration. However, if you want to set up a static configuration for your Datalogger, you can access the internet page via the link RMSxxxxxxx: 8888, as shown in the figure (e.g. RMS00000007).



By entering the credentials: username = admin and password = admin, you can change the configuration from dynamic to static by selecting the network window (see [blue arrow](#)) and then the “STATIC” option (see [green arrow](#)).





To complete the operation, click “Apply” (see red arrow).



## 12.4.9. Local monitoring

The datalogger makes it possible to obtain an additional monitoring system (**local monitoring**), which can be used locally on a web page (therefore, also without an internet connection) and accessed from any device present in the same local network as the datalogger.

### 12.4.9.1. Requirements for installation of local monitoring

In order to install the local monitoring system on the datalogger, the customer must ensure that:

- The datalogger is connected to the local network and to the internet (the internet connection is only required during installation and configuration of the local monitoring system).
- A static address (to be provided by the customer) with gateway and subnet mask is available for viewing the page locally.

### 12.4.9.2. Features of local monitoring

After installation and configuration, local monitoring makes it possible to monitor the fundamental parameters of the photovoltaic system, even without an internet connection, from any device connected to the same local network.

In particular, it is possible to monitor the power and energy of the inverters and the storage systems over the last 7 days. It is also possible to view alarms, and other information such as temperature, peak daily power, CO<sub>2</sub> gains and savings.

Below is an example of a local monitoring page.



Figure 99 – Example of local monitoring page

### **13. Warranty terms and conditions**

To view the “Warranty Terms and Conditions” offered by ZCS Azzurro, please refer to the documentation inside the product box and on the website [www.zcsazzurro.com](http://www.zcsazzurro.com).





---

THE INVERTER THAT LOOKS AT THE FUTURE

**[zcsazzurro.com](http://zcsazzurro.com)**



Zucchetti Centro Sistemi S.p.A.  
Green Innovation Division  
Palazzo dell'Innovazione - Via Lungarno, 167  
52028 Terranuova Bracciolini - Arezzo, Italy  
[zcscompany.com](http://zcscompany.com)

